

# CENTRIFUGAL RANGE

QB PERIPHERAL VANE

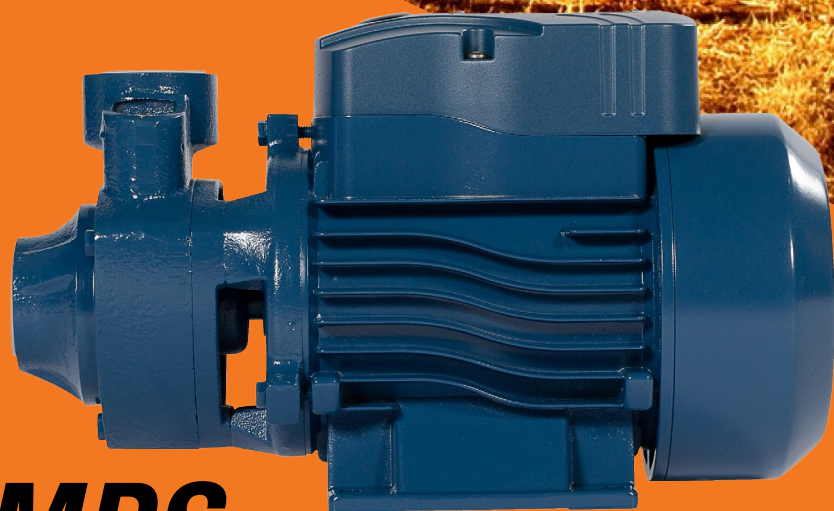

**TRACER PUMPS**

LEADING IN MOTION

24-01

# PERIPHERAL VANE PUMP

## QB

- ✔ High strength terminal box
- ✔ Pure copper water injection screw
- ✔ Antirust pump body
- ✔ Antirust links
- ✔ Waterproof outlet hole
- ✔ Thickened aluminum barrel

### INSTALLATION AND USE

They are recommended for pumping clean water without abrasive particles, and liquids that are chemically non aggressive for the materials of which the pump is made. As a result of their reliability and the fact that they are easy to use and are economical, these pumps are suitable for domestic use and in particular for distribution water in combination with small pressure sets and for the irrigation of gardens and allotments.

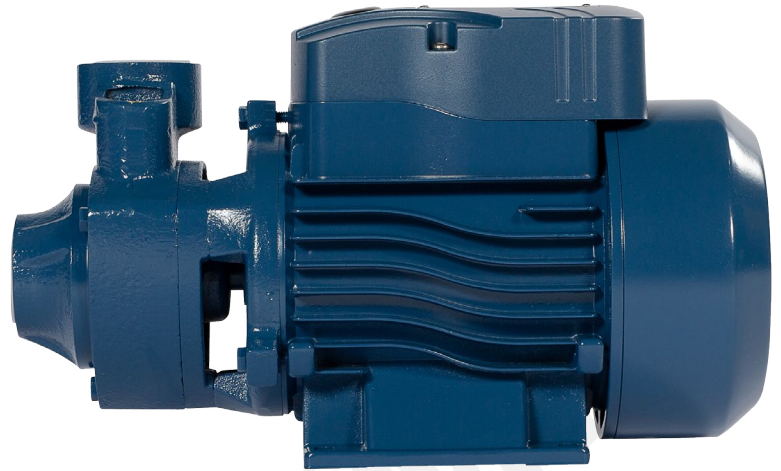

### RANGE OF PERFORMANCE

- ✔ Flow rate up to 60 L/min (3.6 m³/h)
- ✔ Head up to 60 m

### FEATURES

- ✔ Liquid Type: Clean water
- ✔ Applications: Water supply systems, pressure systems, irrigation pumps
- ✔ Typology: Surface

### APPLICATION LIMITS

- ✔ Manometric suction lift up to 8 m
- ✔ Liquid temperature up to +40°C
- ✔ Ambient temperature up to +40 °C

### CONSTRUCTION

- ✔ Pump Body: Cast iron
- ✔ Impeller: Brass, with radial peripheral vanes
- ✔ Motor Shaft: 45# steel or stainless steel 304
- ✔ Mechanical Seal: Ceramic - graphite
- ✔ Electric Motor: Single-phase 230V-50Hz with condenser and thermal overload protector built into the copper winding
- ✔ Insulation: Class B

### MODEL INSTRUCTION

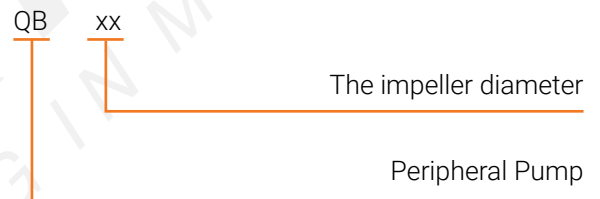



**DIAGRAM**

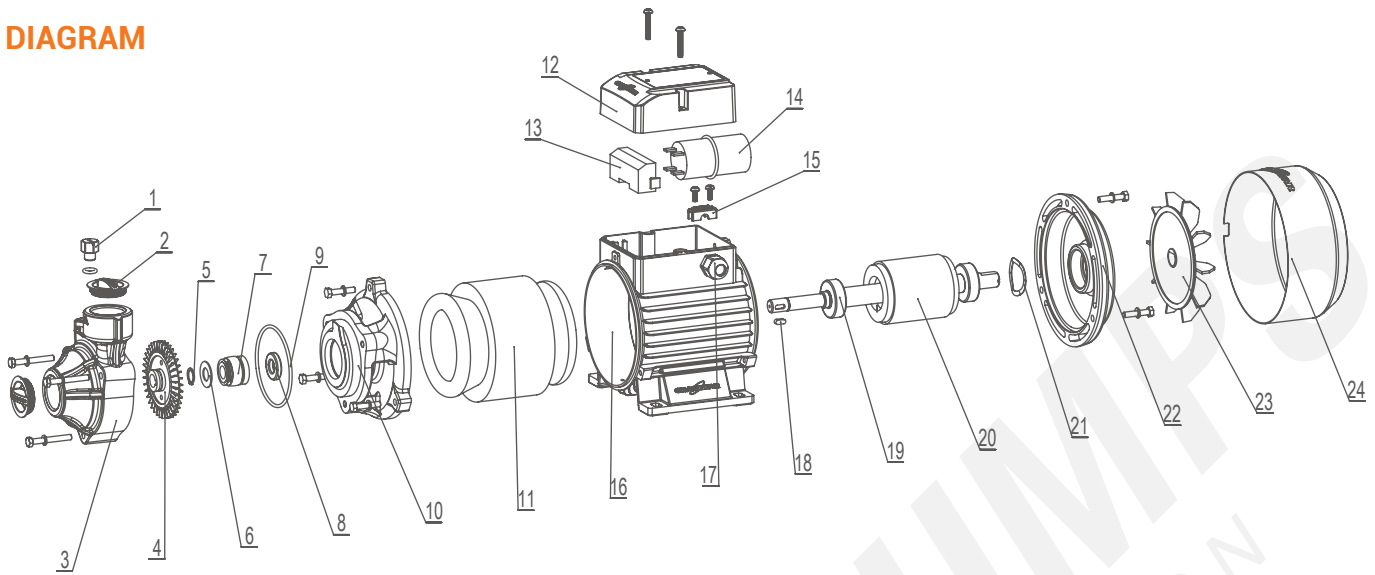

No.	Description	No.	Description	No.	Description	No.	Description
1	Air faucet	7	Mechanical seal	13	Terminal board	19	Bearing
2	Dust cap	8	Water proof ring	14	Capacitor	20	Rotor
3	Pump head	9	O ring	15	Cable fixer	21	Wave spring
4	Impeller	10	Coupling	16	Motor shell	22	End cover
5	Shaft circlip	11	Stator	17	Cable protector	23	Fan
6	Flat washer	12	Terminal box cover	18	Key	24	Fan cover

**PRODUCT PARAMETERS**

No.	Model	Power		Voltage	Max.head	Max.flow		Size	Suct.Max	N/W
		kW	HP			L/min	m <sup>3</sup> /h			
1	QB60	0.37	0.5	220V/50Hz	36	34	2	1"x1"	8	5.3
2	QB70	0.55	0.75	220V/50Hz	48	50	3	1"x1"	8	8.5
3	QB80	0.75	1	220V/50Hz	60	60	3.6	1"x1"	8	10

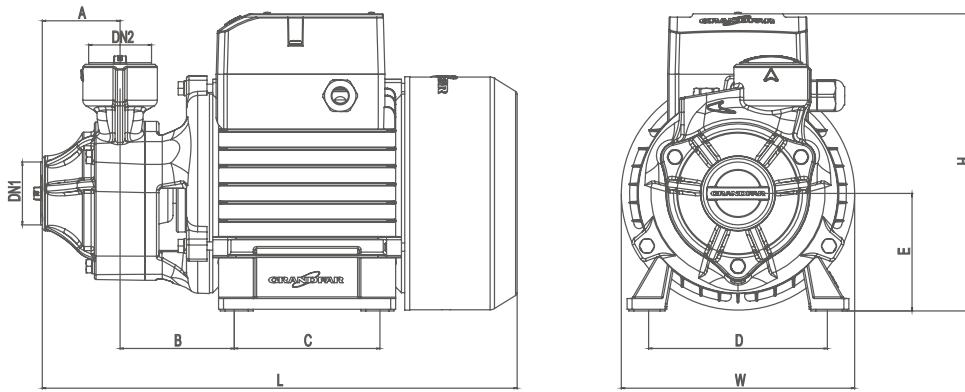

No.	Model	DN1	DN2	L	L1	L2	L3	W	W1	H	H1
1	QB60	1"	1"	252	41	66	80	110	83	155	63
2	QB70	1"	1"	288	48	71	84	134	115	180	71
3	QB80	1"	1"	288	48	71	84	134	115	180	71

**PERFORMANCE CURVE**

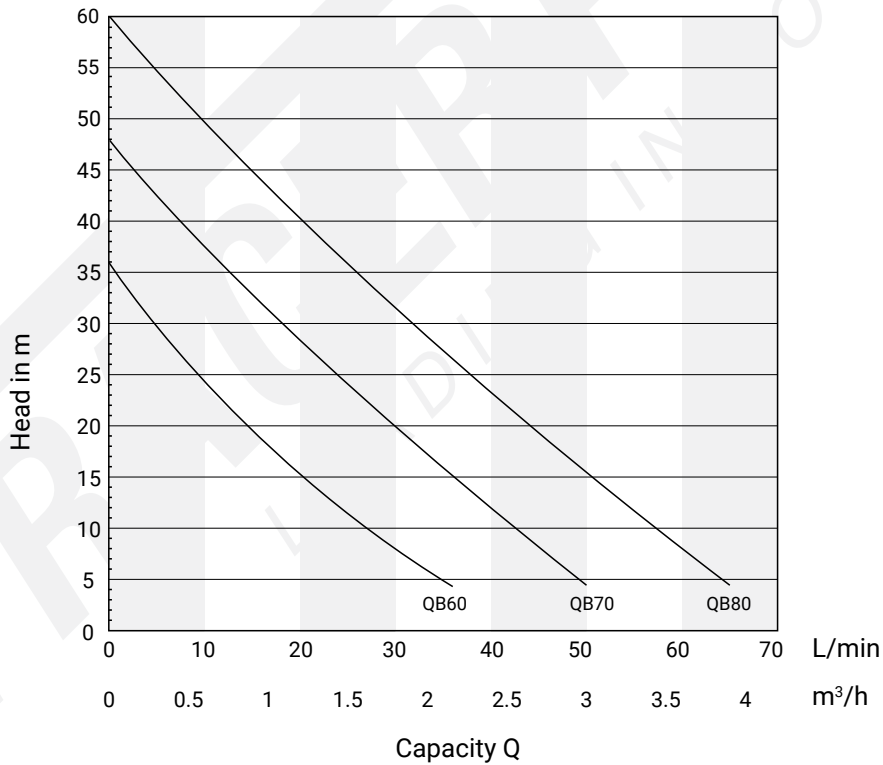

No	Model	Q(m³/h)	0	0.3	0.6	0.9	1.2	1.5	1.8	2.1	2.4	3	3.6
		Q(L/min)	0	5	10	15	20	25	30	35	40	50	60
1	QB60	H(m)	36	32	28	25	18	11	6	2	-	-	-
2	QB70		48	43	39	34	29	24	19	14	8	3	-
3	QB80		60	56	51	45	41	36	25	20	15	10	4