

CENTRIFUGAL RANGE

DZA CLOSED COUPLED



TRACER PUMPS

LEADING IN MOTION

DZA(S) FLANGED

Stub-shaft pump

Applications

The DZA range of flanged end suction pumps (according to DIN24255) are suitable for applications in irrigation, transfer and pressure boosting.

Pumped liquids include water containing >0.001kg/liter grit and liquids compatible with 304S/S.

Performance limits

Maximum working pressure:	10bar
Operating temperature range:	-20°C to +110°C
Mechanical seal construction:	Viton/Carbon/Sil.Carbide
Casing:	304S/S
Impeller:	304S/S
Shaft:	316L S/S

Symbols

Typical example:

DZA-65-40-160/4.0

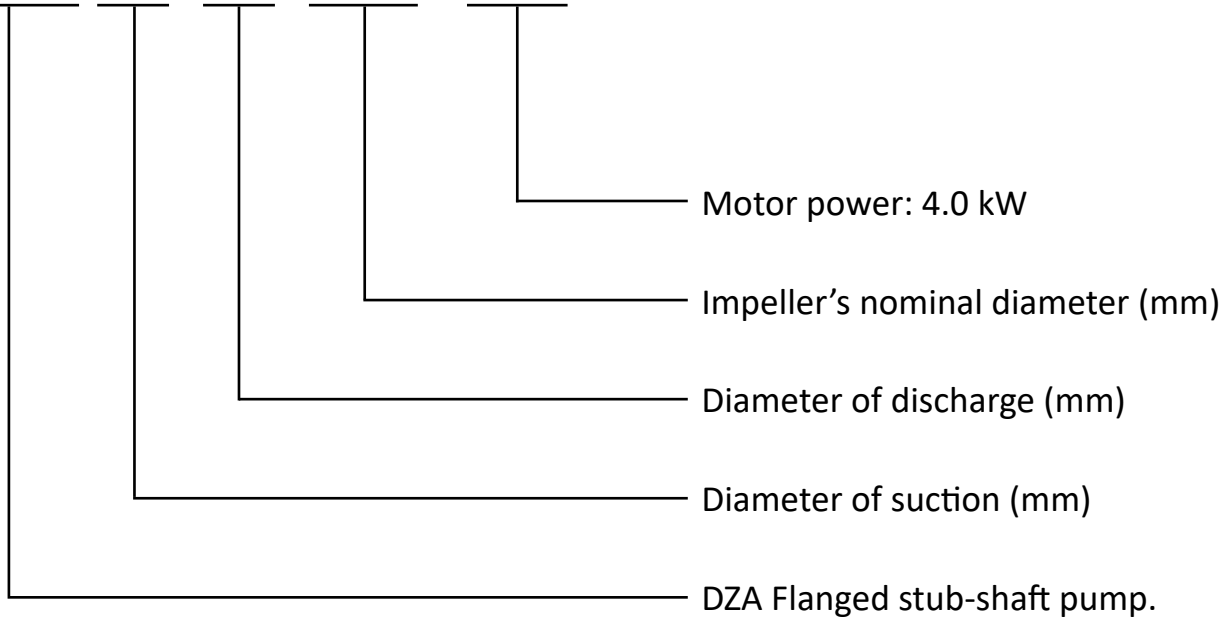

Curve

MODEL	HIGHEST EFFICIENCY DUTY POINT		RPM	PUMP EFFICIENCY %	EQUIPPED MOTOR POWER	
	CAPACITY m3/h	HEAD m			kW	HP
50-32-125/1.1	12.5	20	2900	61	1.1	1.5
50-32-160/1.5	10	25		56	1.5	2.0
50-32-160/2.2	12.5	32		62	2.2	3.0
50-32-200/3.0	10	40		48	3.0	4.0
50-32-200/4.0	12.5	50		50.5	4.0	5.5
65-40-125/1.5	20	17		68	1.5	2.0
65-40-125/2.2	25	20		74	2.2	3.0
65-40-160/3.0	20	27		66	3.0	4.0
65-40-160/4.0	25	32		66	4.0	5.5
65-40-200/5.5	20	42		57	5.5	7.5
65-40-200/7.5	25	50		62	7.5	10
65-50-125/3.0	40	18		70	3.0	4.0
65-50-125/4.0	50	20		74	4.0	5.5
65-50-160/5.5	40	28		71	5.5	7.5
65-50-160/7.5	50	32		72	7.5	10.0
65-50-190/11	40	47		73	11	15
65-50-200/11	50	50		72	11	15
80-65-125/4.0	75	11		72	4.0	5.5
80-65-125/5.5	75	15		74	5.5	7.5
80-65-125/7.5	75	21		74	7.5	10
80-65-156/11	100	21	74	11	15	
80-65-160/11	100	26	74	11	15	
80-65-200/15	100	34	75	15	20	
80-65-200/18.5	100	43	75	18.5	25	
80-65-200/22	100	50	75	22	30	

OPERATING

Performance data

MODEL	POWER		CAPACITY																
	kW	HP	l/min	0	100	150	200	300	333	360	400	450	500	600	700	800	1000	1200	
			m3/h	0	6	9	12	18	20	22	24	27	30	36	42	48	60	72	
HEAD (m)																			
50-32-125/1.1	1.1	1.5	HEAD (m)	24	21.5	20.5	19.5	16	13										
50-32-160/1.5	1.5	2.0		29.5	27	26	25	21	18										
50-32-160/2.2	2.2	3.0		37	33	32	31	29	27										
50-32-200/3.0	3.0	4.0		45	41	40	38	34	32										
50-32-200/4.0	4.0	5.5		55	51	50	49	46	45	43									
65-40-125/1.5	1.5	2.0		20			19	18	17	16.5	15	14	12.5	10	7				
65-40-125/2.2	2.2	3.0		26			23.5	22.5	22	21.5	21	20.5	19.5	16.5	13				
65-40-160/3.0	3.0	4.0		31			29	27.5	27	26.5	25.5	25	24	22	19				
65-40-160/4.0	4.0	5.5		39			35.5	34.5	34	33.5	32.5	32	31	29	26				
65-40-200/5.5	5.5	7.5		47			43	42.5	42	41.5	41	40.5	39	37	33				
65-40-200/7.5	7.5	10		57			53	52.5	52	51	50	49	48	46.5	44.5				
65-50-125/3.0	3.0	4.0		22.5							20	19.5	19	18.5	17.5	16	13	9	
65-50-125/4.0	4.0	5.5		25.5							23	22.5	22	21.5	20.5	20	17	13.5	
65-50-160/5.5	5.5	7.5		33							29.5	29	28.5	28	27	26	24	20	
65-50-160/7.5	7.5	10		39							36	35	34.5	34	33.5	32.5	29	24	
65-50-190/11	11	15		53									47	46.5	45	43.5	39	32	
65-50-200/11	11	15		57.5									52	51	50.5	50	47	41	

MODEL	POWER		CAPACITY												
	kW	HP	l/min	600	650	700	800	1000	1200	1500	1800	1900	2000	2100	2200
			m3/h	36	39	42	48	60	72	90	108	114	120	126	132
HEAD (m)															
80-65-125/4.0	4.0	5.5	HEAD (m)	18	17.5	17	16	14	11.5	8	4.5				
80-65-125/5.5	5.5	7.5		22.5	22	21.5	20.5	18.5	16	12.5	8.5	7			
80-65-125/7.5	7.5	10		27.5	27	26.5	26	24	21.5	18	14	12	10.5		
80-65-156/11	11	15				31	30	28	26	23	18	16	14.5	13	
80-65-160/11	11	15				36	35	33	31	28	23	21	19.5	18	16.5
80-65-200/15	15	20				44	43	41	39	36	32	30	28	26	23
80-65-200/18.5	18.5	25				51	50	49	48	45	41	39	37	35	33
80-65-200/22	22	30				57	56	55	54	51	47	45.5	44	42	40

Exploded view

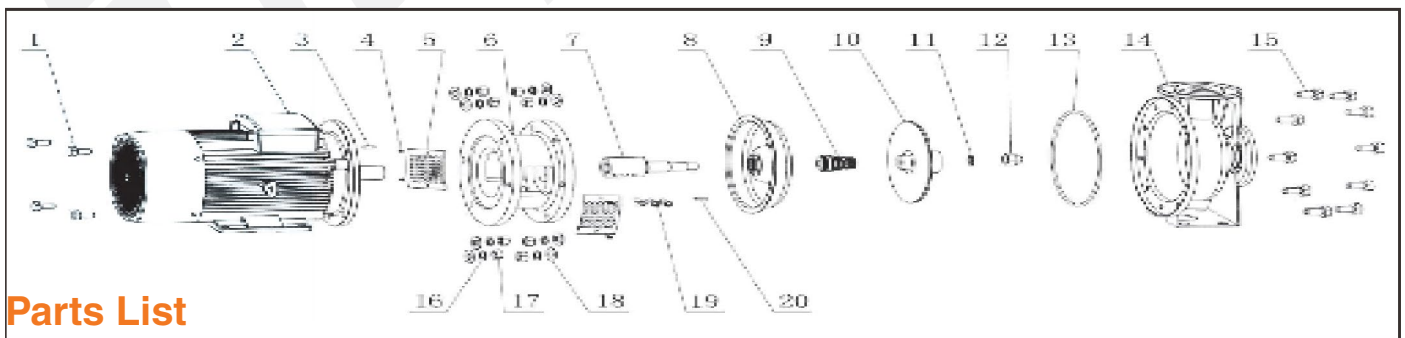

Parts List

NO.	DESCRIPTION	NO.	DESCRIPTION	NO.	DESCRIPTION
1	Fan Cover Screw	6	Motor Bracket	11	Spring Washer
2	Electric Motor	7	Shaft and coupling	12	Impeller Nut
3	Key	8	Backing Plate	13	O-ring
4	Shield Screw	9	Mechanical Seal	14	Pump Casing
5	Shield	10	Impeller	15	Casing Bolts

PERFORMANCE CURVES

50 - 32 Range

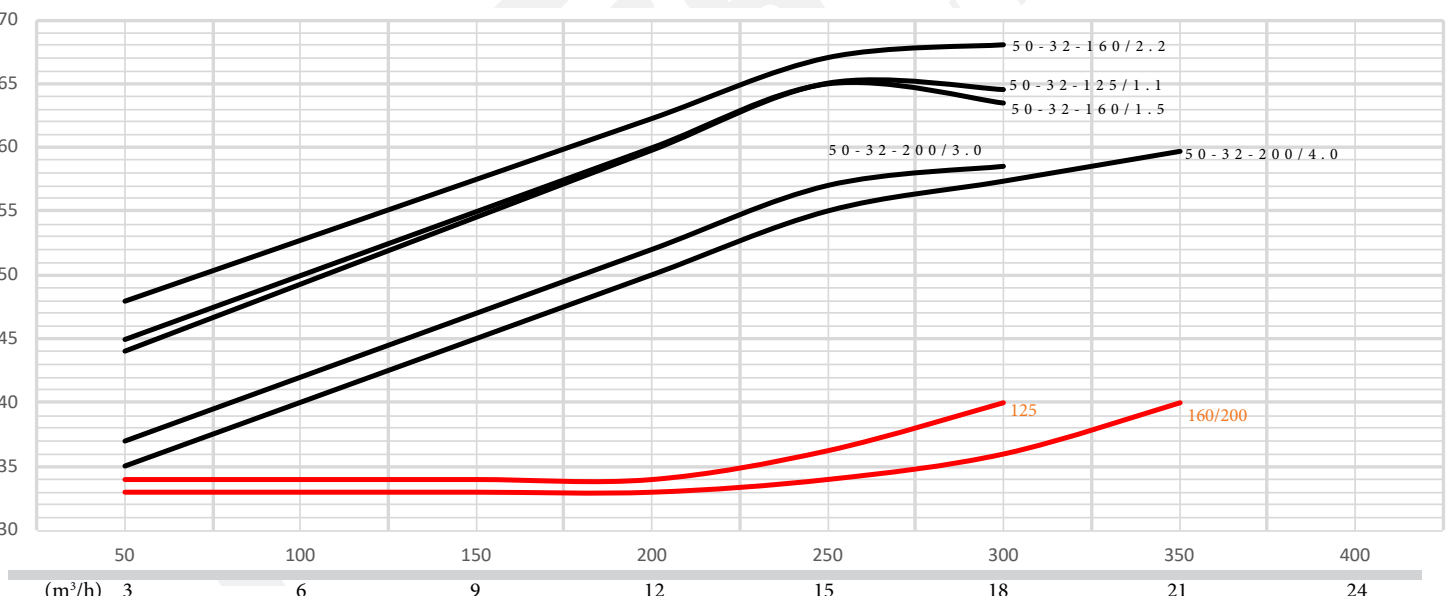
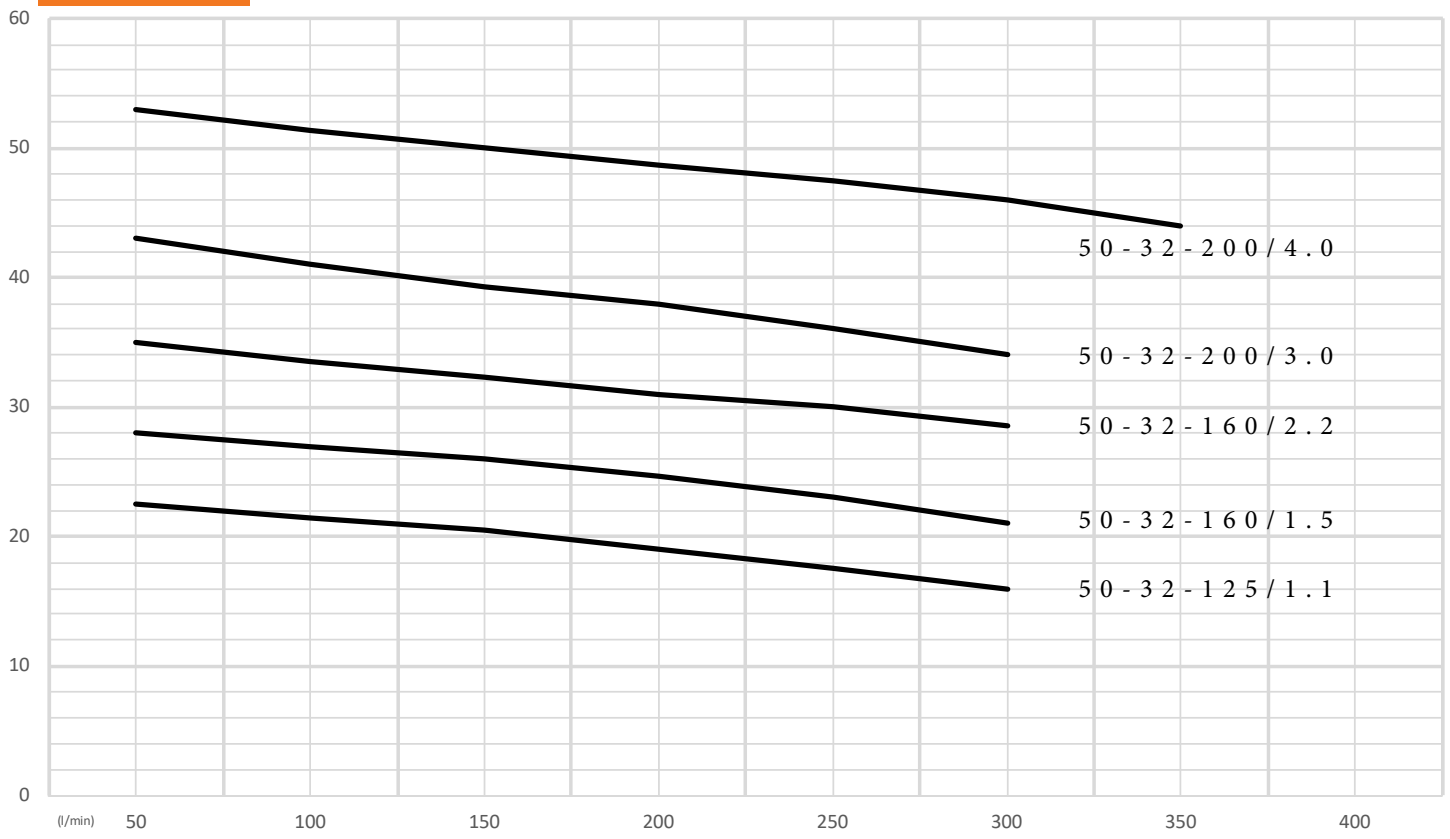

NPSH
8
6
4
2

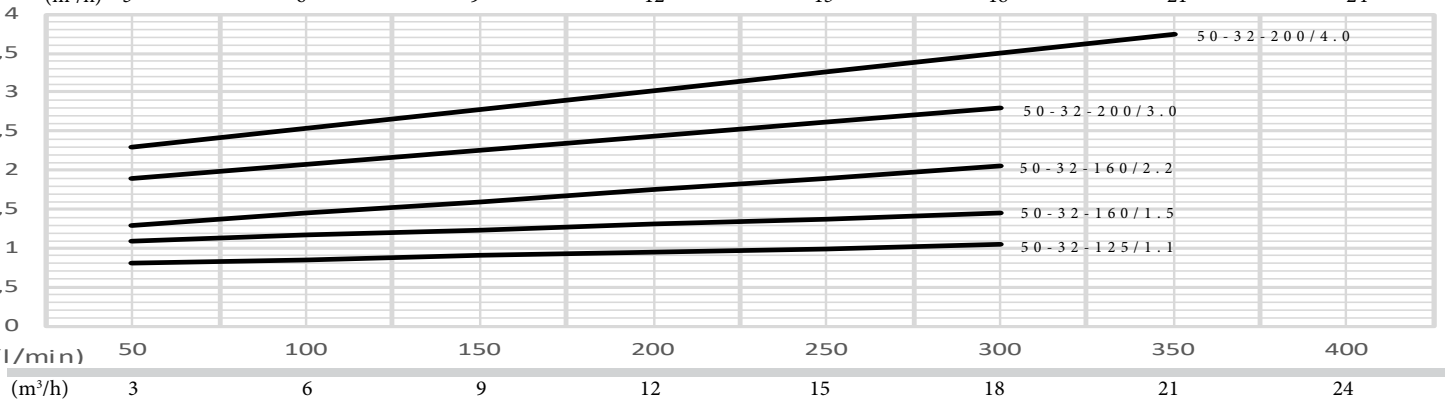

PERFORMANCE CURVES

65 - 40 Range

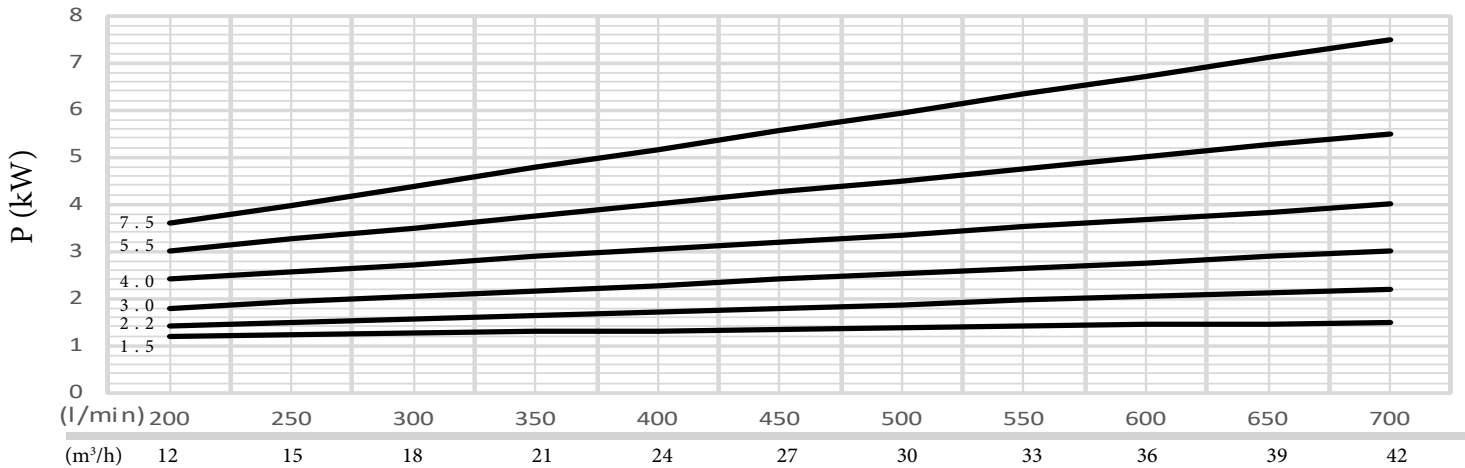
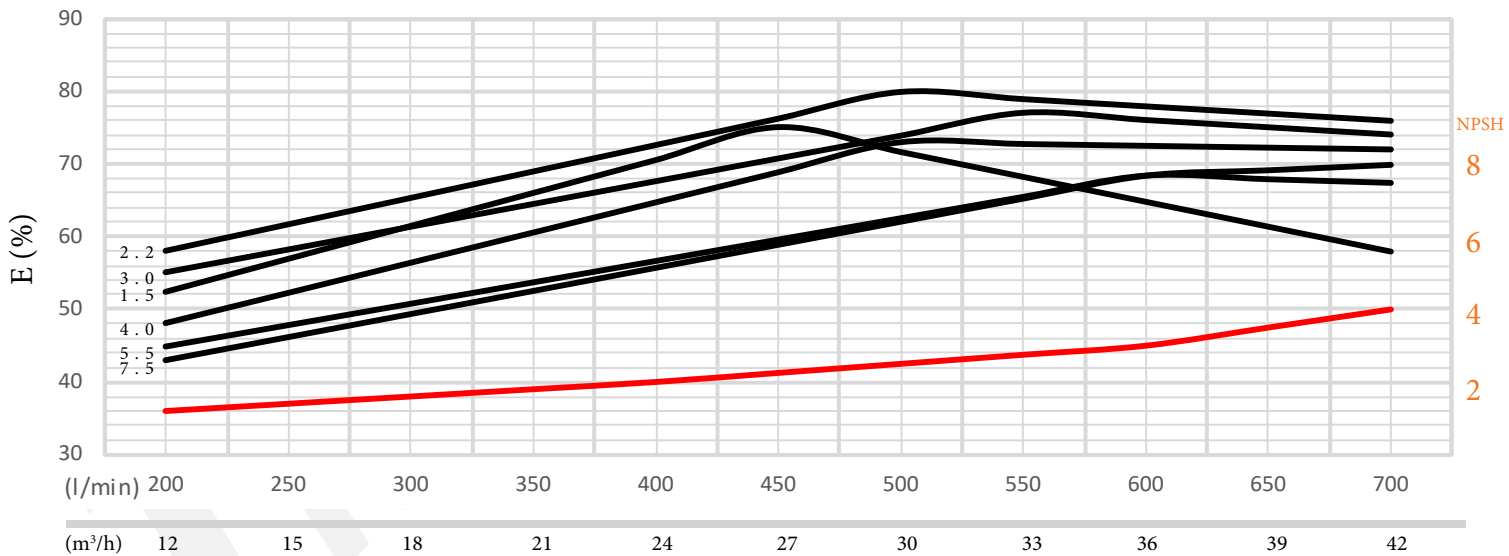
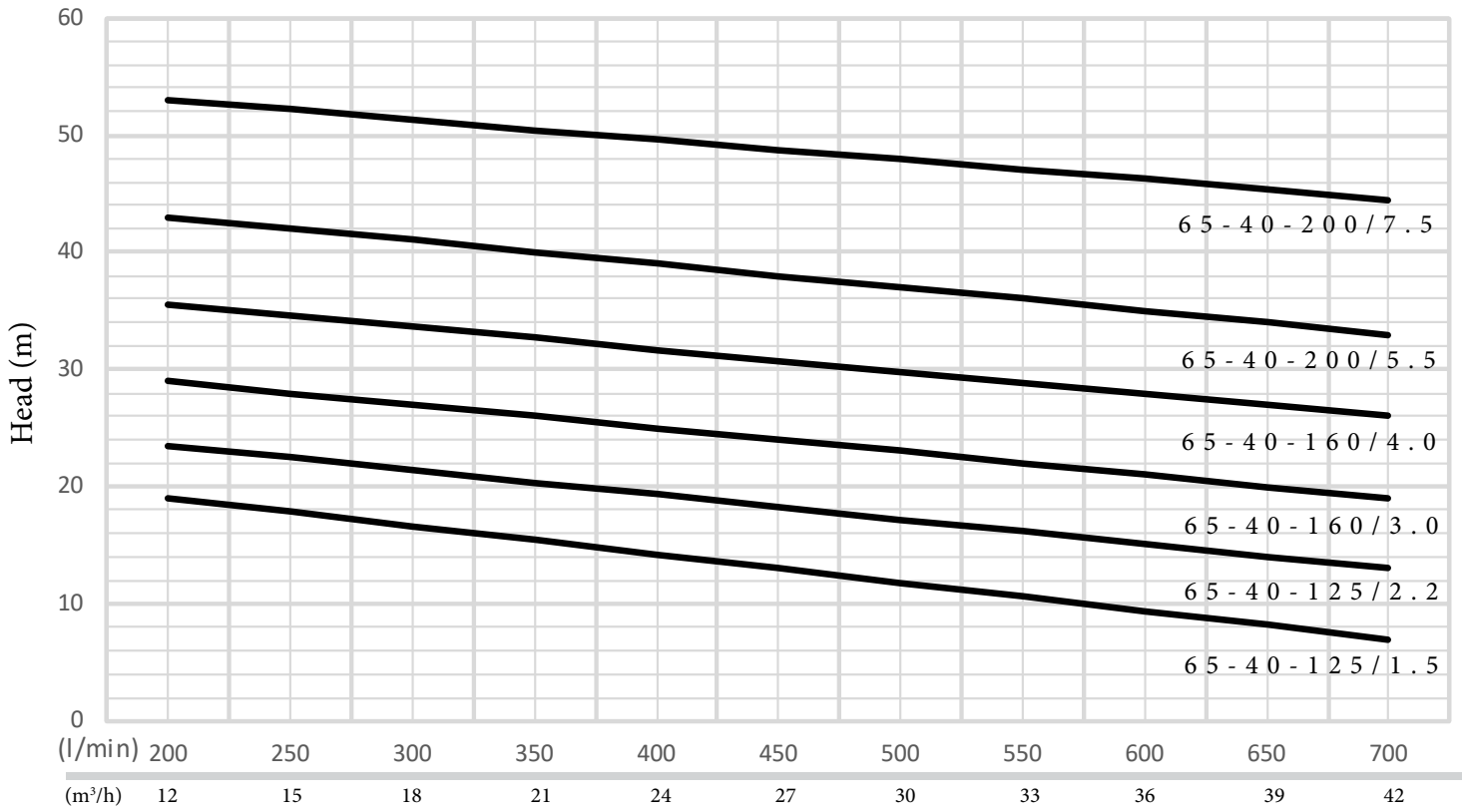

PERFORMANCE CURVES

65 - 50 Range

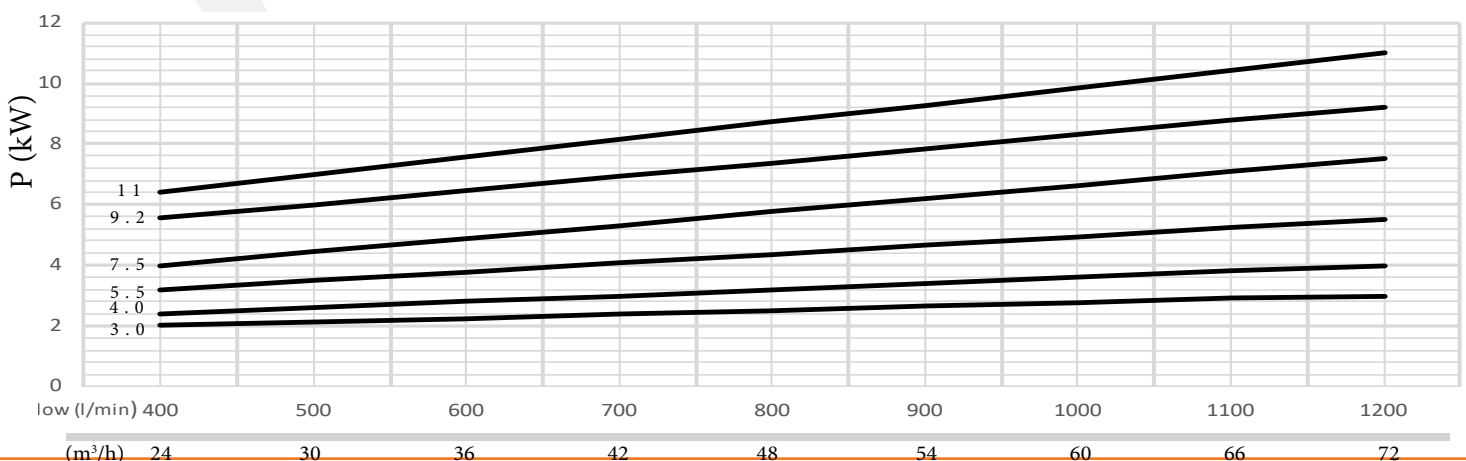
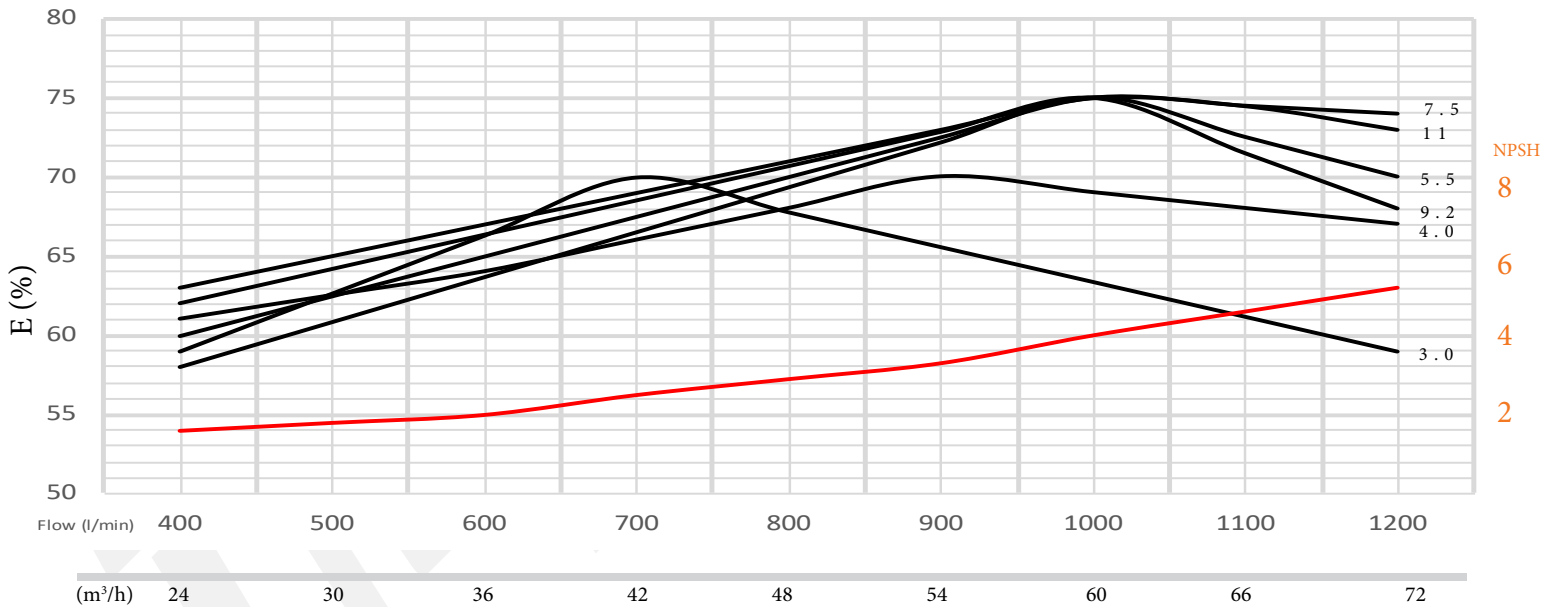
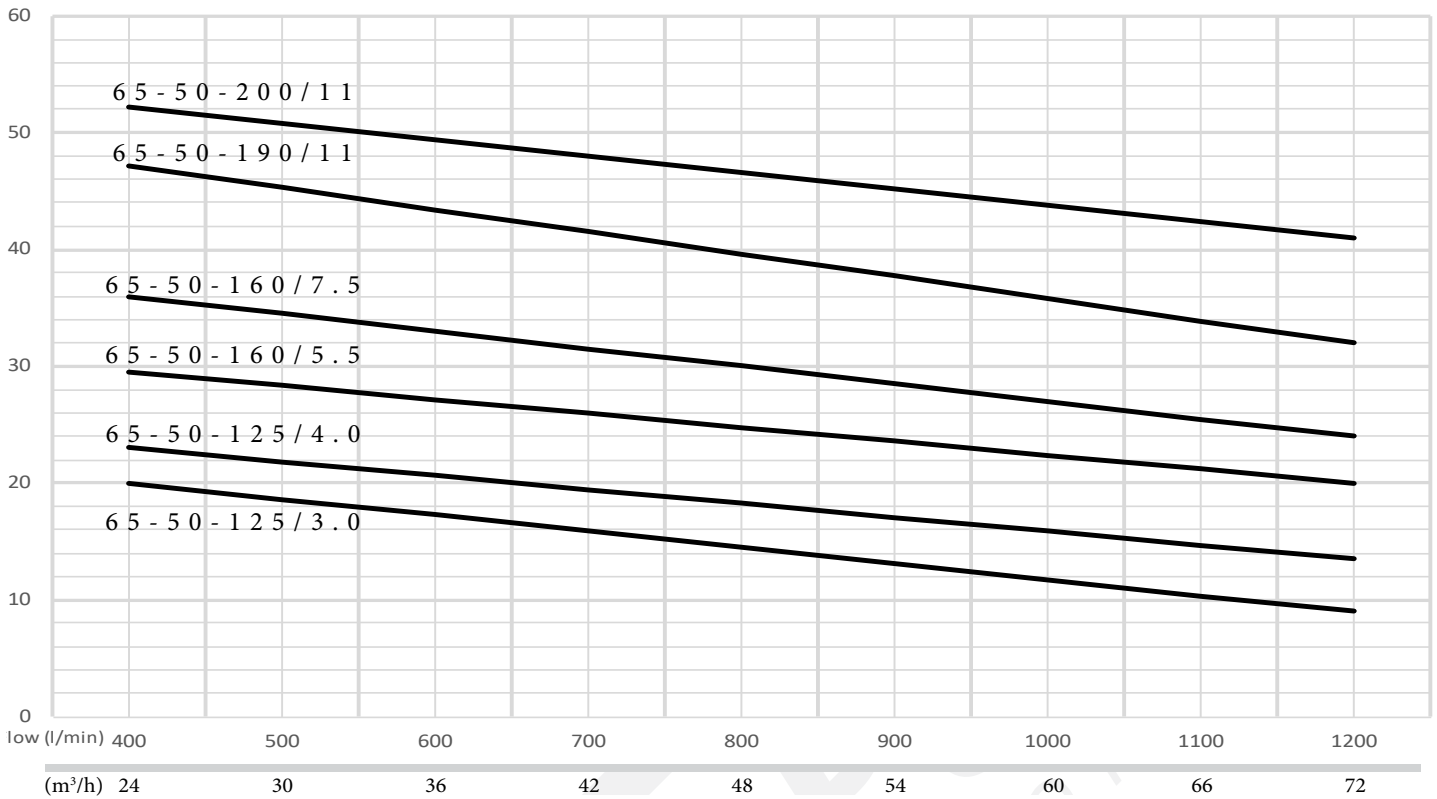

PERFORMANCE CURVES

80 - 65 Range

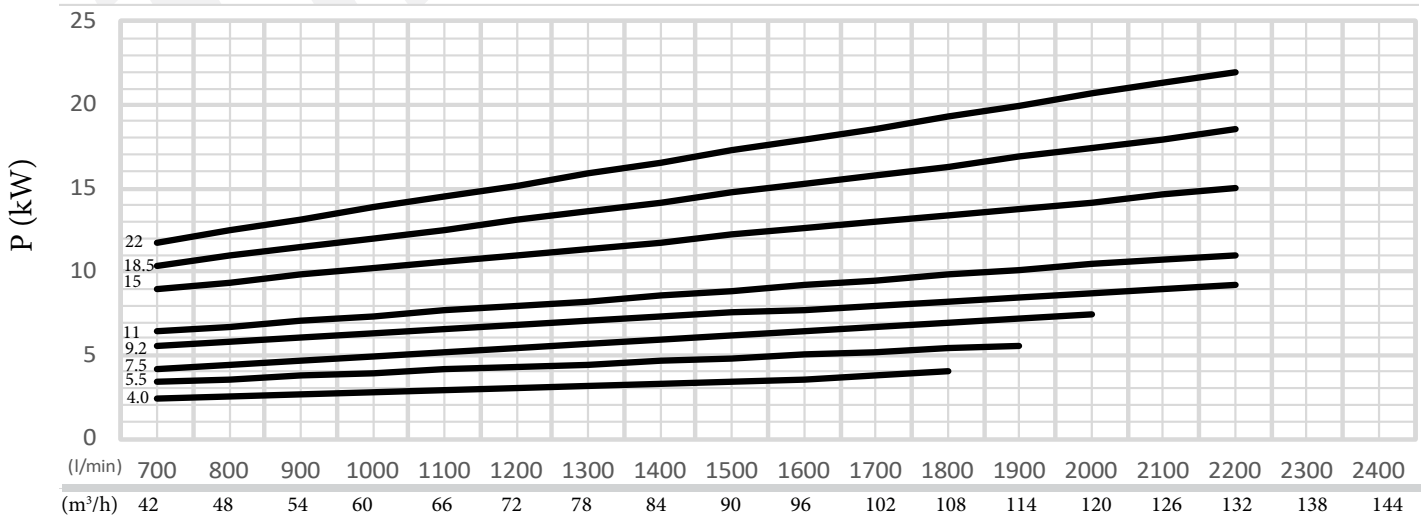
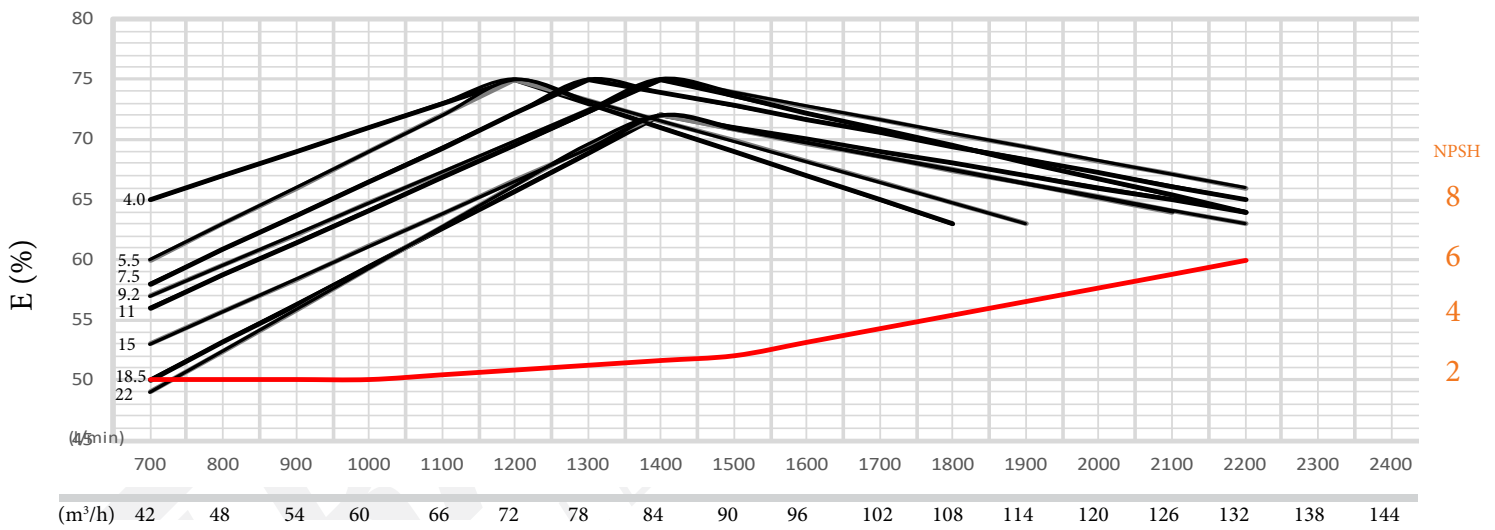
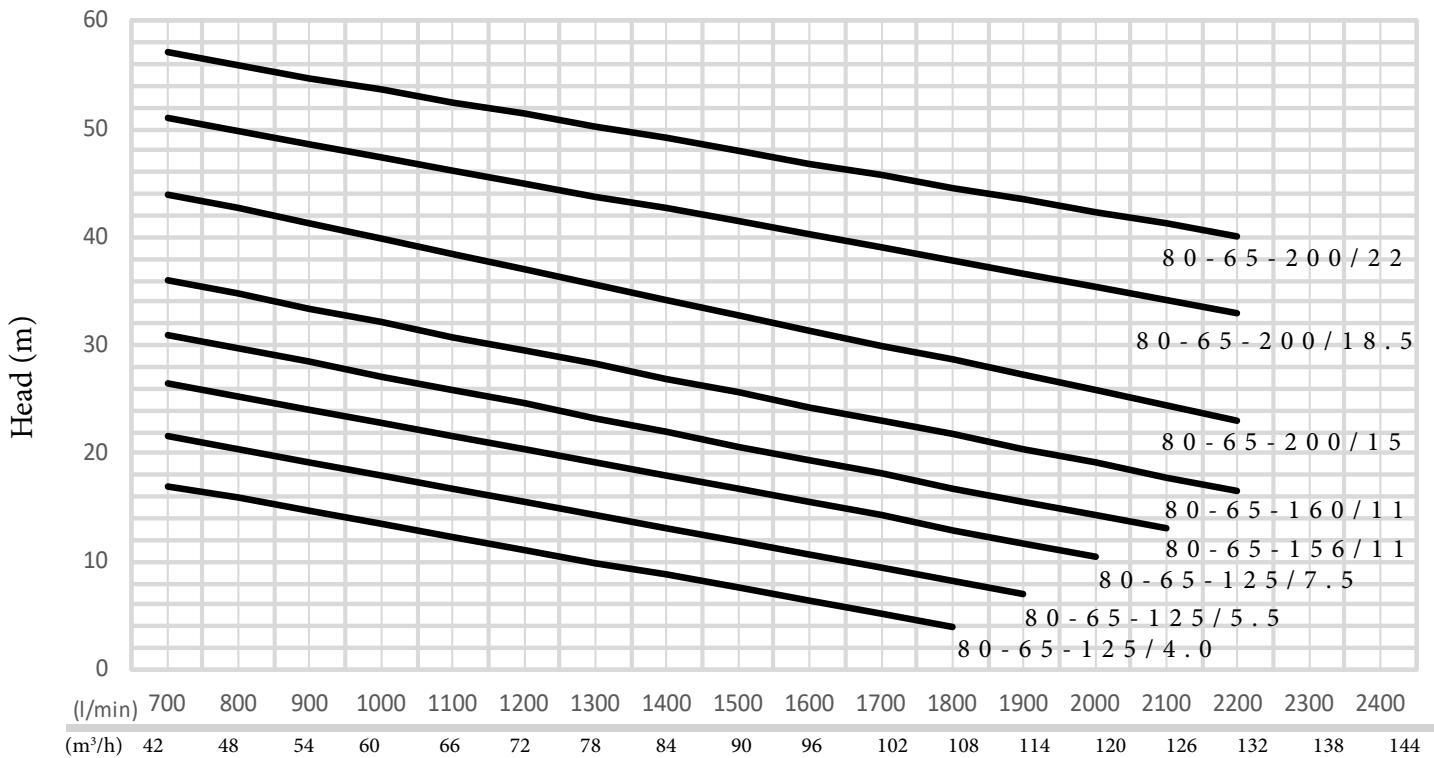

DZA(S) 50 & 65

1.1~11kW

Pump outline diagram & Dimensions

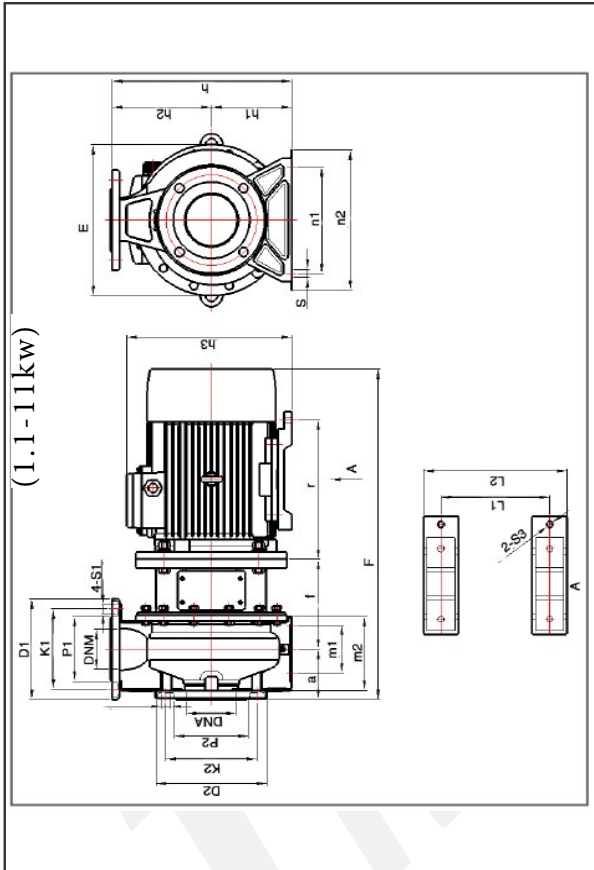

MODEL	Φ E	F	h	h1	h2	h3	a	m1	m2	n1	n2	S	L1	L2	L3	S3	r	f	D2	K2	P2	S2	n	D1	K1	P1	S1	DNA	DNM
50-32-125/1.1	209	444	252	112	140	221	80	70	122	140	190	15	125	165	/	12	186	128	165	125	99	18	4	140	100	76	18	50	32
50-32-160/1.5	244	488	292	132	160	254	80	70	123	190	240	15	140	186	/	12	212	130	165	125	99	18	4	140	100	76	18	50	32
50-32-160/2.2	244	488	292	132	160	254	80	70	123	190	240	15	140	186	/	12	212	130	165	125	99	18	4	140	100	76	18	50	32
50-32-200/3.0	295	547	340	160	180	287	80	70	124	190	240	15	160	212	/	12	248	165	165	125	99	18	4	140	100	76	18	50	32
50-32-200/4.0	295	557	340	160	180	309	80	70	124	190	240	15	190	252	/	12	255	142	165	125	99	18	4	140	100	76	18	50	32
65-40-125/1.5	209	486	252	112	140	234	80	70	121	160	210	15	140	211	/	12	214	128	185	145	118	18	4	150	110	84	18	65	40
65-40-125/2.2	209	486	252	112	140	234	80	70	121	160	210	15	140	211	/	12	214	128	185	145	118	18	4	150	110	84	18	65	40
65-40-160/3.0	244	592	292	132	160	259	80	70	123	190	240	15	160	212	/	12	248	142	185	145	118	18	4	150	110	84	18	65	40
65-40-160/4.0	244	617	292	132	160	281	80	70	123	190	240	15	190	252	/	12	255	142	185	145	118	18	4	150	110	84	18	65	40
65-40-200/5.5	300	644	340	160	180	327	100	70	146	212	265	15	216	286	/	12	278	165	185	145	118	18	4	150	110	84	18	65	40
65-40-200/7.5	300	644	340	160	180	327	100	70	146	212	265	15	216	286	/	12	278	165	185	145	118	18	4	165	110	84	18	65	40
65-50-125/3.0	250	577	292	132	160	259	100	70	148	190	240	15	160	212	/	12	245	152	185	145	118	18	4	165	125	99	18	65	50
65-50-125/4.0	250	557	292	132	160	281	100	70	148	190	240	15	190	252	/	12	255	152	185	145	118	18	4	165	125	99	18	65	50
65-50-160/5.5	300	644	340	160	180	327	100	70	150	212	265	15	216	286	/	12	278	165	185	145	118	18	4	165	125	99	18	65	50
65-50-160/7.5	300	644	340	160	180	327	100	70	150	212	265	15	216	286	/	12	278	165	185	145	118	18	4	165	125	99	18	65	50
65-50-190/11	300	651	360	160	200	327	100	70	152	212	265	15	216	286	/	12	278	172	185	145	118	18	4	165	125	99	18	65	50
65-50-200/11	300	792	360	160	200	411	100	70	152	212	265	15	254	314	/	15	318	198	185	145	118	18	4	165	125	99	18	65	50

DZA(S)

1.1~11kW

Pump outline diagram & Dimensions

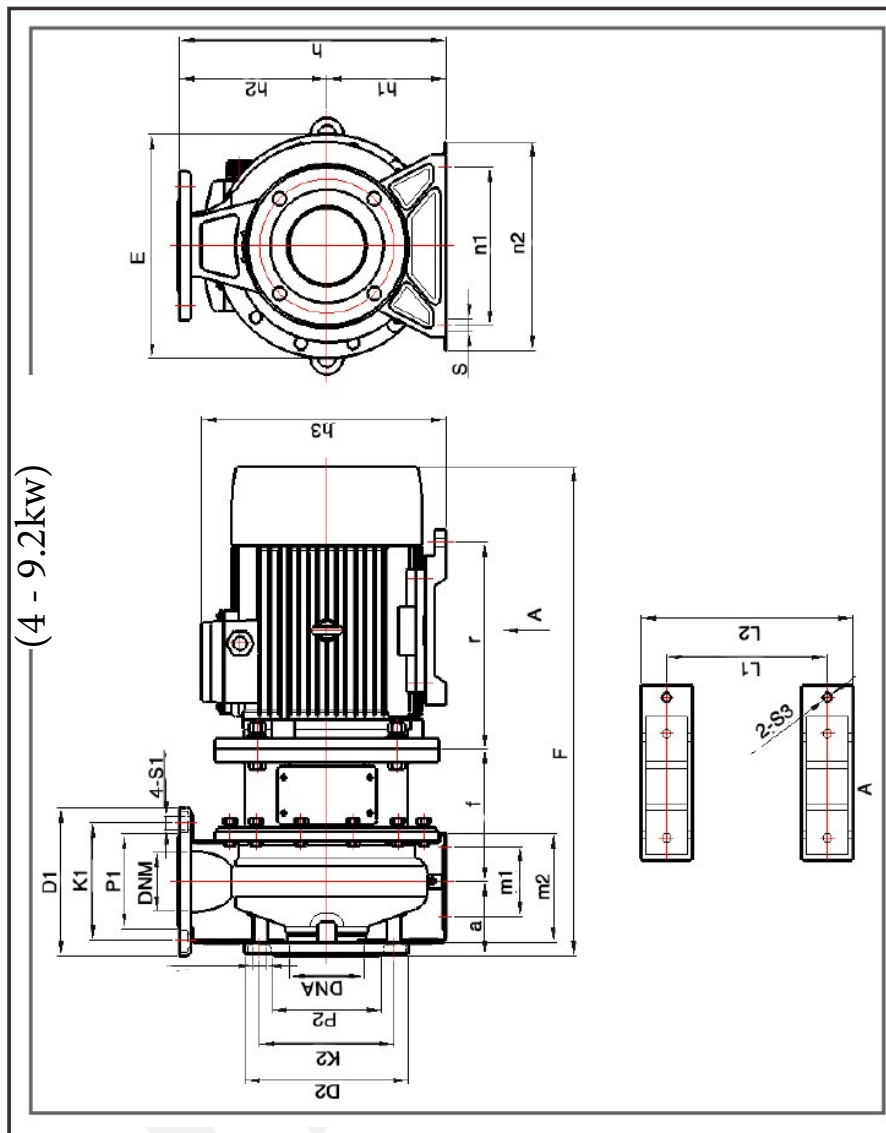

MODEL	Φ E	F	h	h1	h2	h3	a	m1	m2	n1	n2	S	L1	L2	L3	S3	r	f	D2	K2	P2	S2	n	D1	K1	P1	S1	DNA	DNM
80-65-125/4,0	300	644	340	160	180	327	100	70	150	212	265	15	216	286	/	12	278	165	200	160	132	18	4	185	145	118	18	80	65
80-65-125/5,5	300	644	340	160	180	327	100	70	150	212	265	15	216	286	/	12	278	165	200	160	132	18	4	185	145	118	18	80	65
80-65-125/7,5	245	644	340	160	180	327	100	95	155	212	280	15	216	286	/	12	278	165	200	160	132	18	4	185	145	118	18	80	65
80-65-156/11	301	658	360	160	180	327	100	95	155	212	280	15	216	286	/	12	278	165	200	160	132	18	4	185	145	118	18	80	65

DZA(S)

11~22kW

Pump outline diagram & Dimensions

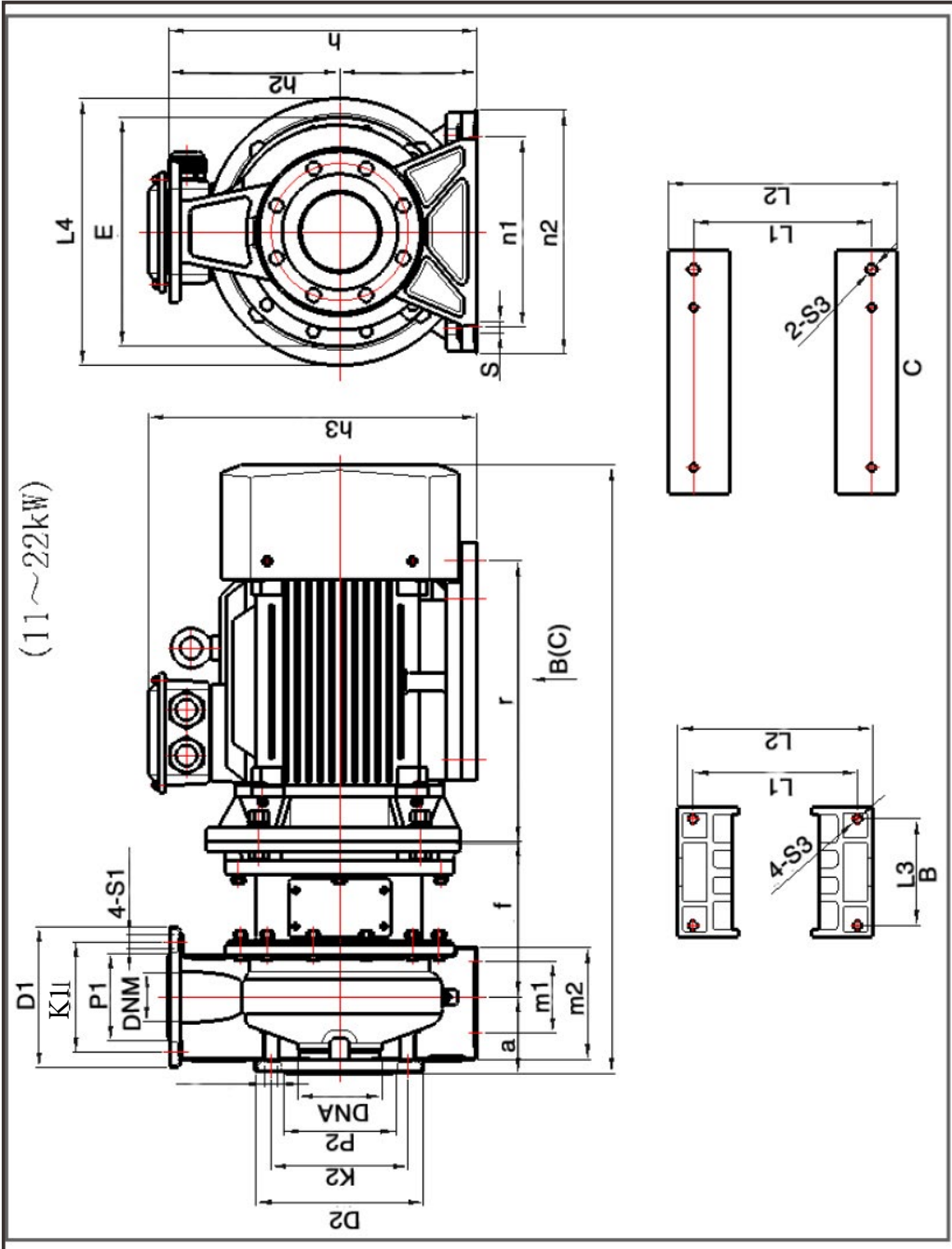

MODEL	ΦE	F	h	h1	h2	h3	a	m1	m2	n1	n2	S	L1	L2	L3	S3	r	f	D2	K2	P2	S2	n	D1	K1	P1	S1	DNA	DNM
80-65-160/11	301	840	405	180	225	432	100	95	155	250	320	15	254	348	/	15	368	150	200	160	132	18	8	185	145	118	18	80	65
80-65-200/15	301	840	405	180	225	432	100	95	155	250	320	15	254	348	/	15	368	205	200	160	132	18	8	185	145	118	18	80	65
80-65-200/18.5	301	840	405	180	225	432	100	95	155	250	320	15	254	348	/	15	368	205	200	160	132	18	8	185	145	118	18	80	65
80-65-200/22	301	840	405	180	225	432	100	95	155	250	320	15	254	348	/	15	368	205	200	160	132	18	8	185	145	118	18	80	65

DZA(S) SINGLE PHASE

Flanged motor

Applications

These motors are suitable for the occasion requiring low starting torque and long-term continuous working, such as home electric appliances, pumps, fans, and recording meters, etc.

Features

Running single or dual capacitors.

Frame Size:	80-90
Rated Power Range:	2 pole 1.1kW -2.2kW
Housing Material:	Aluminium (plastic terminal box)
Rated Voltage:	220V ~ 240V± 5%, 50Hz
Protection Class:	IP54/IP55
Insulation Class:	Class B/F



Performance data

FRAME SIZE	POWER (kW)	RATED SPEED (rpm)	CURRENT FULL LOAD 400V I _{FL} - 400V	CURRENT STARTING ÷ CURRENT FULL LOAD	EFFICIENCY %	POWER FACTOR	RATED TORQUE (Nm)	LOCKED ROTOR TORQUE ÷ TORQUE FULL LOAD	TORQUE BREAKDOWN ÷ TORQUE FULL LOAD	STARTING CAPACITOR 250V
90L	2.2	2800	13.7	4.8	77	0.95	22.47	0.30	1.7	40

Outline and Installation Dimensions

FLANGE SPECIFICATION: B5

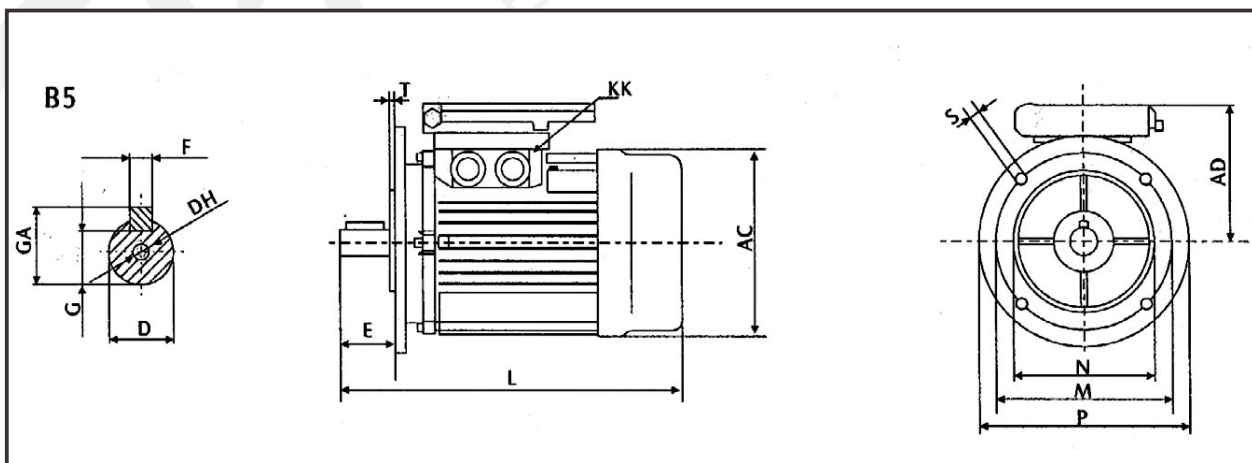

FRAME SIZE	A	AB	AC	AD	B	C	D	DH	E	F	G	H	K	KK	L	M	N	P	S	T	GA
90L	140	174	175	158	125	56	24	M8X19	50	8	20	90	10	2-M20X1.5	350	165	130	200	12	3.5	27

DZA(S) THREE PHASE

Flanged motor C/I

Features

Frame Size Range:	H80~H355
Housing Material:	Frame, flange and bracket, grey cast iron, conduit box-steel
Standard Mounting Construction:	IEC60034-7
Protection Enclosed Class:	IP55 (IEC60034-5)
Cooling Method:	IC411 (IEC60034-6)
The special winding design can work for multi-frequencies (50Hz or 60Hz)	
Can withstand 1.5 times the rated current for 2 minutes (IEC60034-1)	
Anti-condensation heater is available.	
PTC or Pt100 thermistors are available to protect the winding and bearings.	

WIRING

Standard 3-phase motors can be connected using the star or delta method.

Star connection is achieved by wiring W2,U2, V2 to each other; and U1, V1, W1 leads to voltage supply.

Delta connection is achieved by wiring the end of a phase to the head of another.

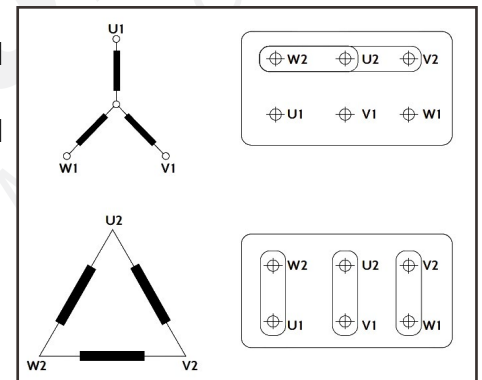

Insulation classification

The motors have insulation class F while the temperature rise is for class B ensuring a longer service life.

Class H insulation motors can be manufactured at the customer's request.

Under specified measuring conditions in accordance with IEC 60034-1 standard, insulation class F for an electric motor means that at the ambient temperature of 40°C the temperature rise of its windings may be maximum 165K with the additional temperature margin of 10K.

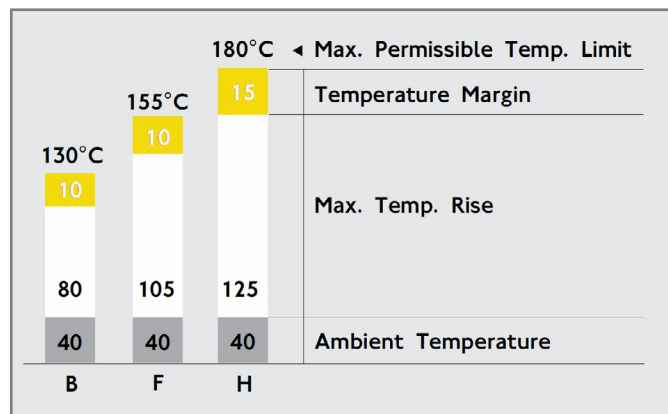

Degree of protection

According to IEC 60034-5 standard, electric motors are provided with IP code which determines the degree of protection ensured by the housing against access to dangerous parts, introducing foreign matter and/or water.

Our motors comply with IP55 protection class as standard.

THE FIRST CHARACTERISTIC NUMERAL: PROTECTION FROM INTRODUCTION OF SOLID FOREIGN MATTER		THE SECOND CHARACTERISTIC NUMERAL: PROTECTION AGAINST PENETRATION OF WATER AND ITS HARMFUL EFFECTS	
0	Non-protected machine	0	Non-protected machine
1	Machine protected against solid objects greater than 50mm	1	Machine protected against dripping water
2	Machine protected against solid objects greater than 12mm	2	Machine protected against dripping water when tilted up to 15°
3	Machine protected against solid objects greater than 2.5mm	3	Machine protected against spraying water
4	Machine protected against solid objects greater than 1mm	4	Machine protected against splashing water
5	Dust protected machine	5	Machine protected against water jets
6	Dust-tight machine	6	Machine protected against heavy seas

Number of starts per hour

The number of starts per hour is dependant on the inertia of the driven load and the load torque demand. A guide to generally acceptable starts per hour would be as per table.

STARTS PER HOUR	
FRAME SIZE	2 POLE
80	16
90	14
100	12
112	10
132	8
160	6
180	4

Bearings

FRAME SIZE	DRIVING END	NON DRIVING END
	2 POLE	2 POLE
80	6206 2Z/C3	6206 2Z/C3
90	6206 2Z/C3	6206 2Z/C3
100	6206 2Z/C3	6206 2Z/C3
112	6207 2Z/C3	6207 2Z/C3
132	6208 2Z/C3	6208 2Z/C3
160	6209 2Z/C3	6209 2Z/C3
180	6211/C3	6211/C3

PERFORMANCE

Data

NET WEIGHT kg	NOISE LEVEL LW db(A)	TORQUE MAXIMUM ÷ TORQUE FULL LOAD	TORQUE STARTING ÷ TORQUE FULL LOAD	RATED TORQUE (Nm)	POWER FACTOR	EFFICIENCY %	CURRENT FULL LOAD 415V	CURRENT FULL LOAD 400V	CURRENT FULL LOAD 380V	RATED SPEED (rpm)	POWER (kW)	FRAME SIZE
17	50	2.2	2.6	7	0.84	77.3	3.5	2.5	2.7	2830	1.1	80
22	60	2.2	2.7	7	0.84	79.3	4.7	3.3	3.1	2840	1.5	90L
24	72	2.9	2.7	7.4	0.85	81.7	4.4	4.6	4.8	2851	2.2	90L
30	76	2.9	2.7	10	0.87	83.1	5.8	6	6.3	2880	3	100L
38	77	2.9	2.6	13.3	0.88	84.2	7.6	7.8	8.2	2880	4	112M
43	78	3.2	2.7	13.3	0.88	85.7	10.2	10.5	11.1	2880	5.5	112M
57	80	2.6	2.3	18.1	0.88	85.9	10.2	10.5	11.1	2900	5.5	132S
61	80	2.8	2.5	24.5	0.88	87.2	13.5	14.2	16.9	2900	7.5	132S
73	83	2.4	2.2	36.2	0.88	88.4	19.7	20.4	21.4	2910	11	160M
101	86	2.9	2.6	35.8	0.89	88.7	19.4	20.1	21.1	2930	11	160M
111	86	2.9	2.6	48.8	0.89	89.5	26.2	27.2	28.6	2930	15	160M
126	86	2.8	2.5	60.4	0.90	90.2	31.8	32.9	34.6	2930	18.5	160L
176	89	2.8	2.6	71.4	0.90	90.6	37.6	38.9	41	2940	22	180M

Dimensions

FLANGE SPECIFICATION: B3B5

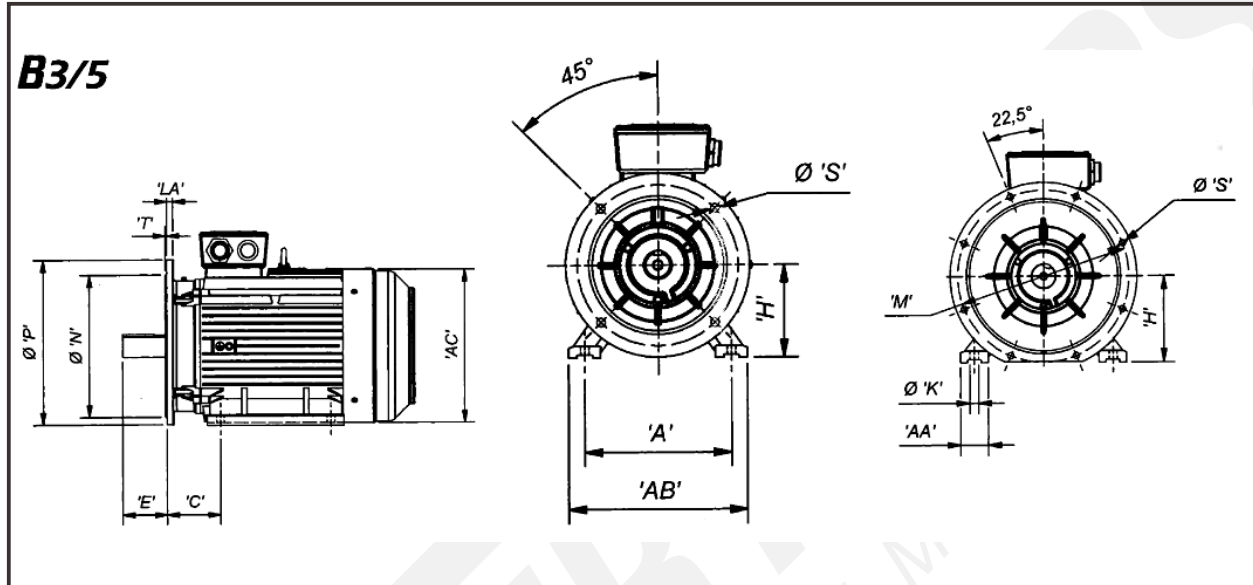

FRAME SIZE	A	AA	AB	AC	C	E	H	ΦK	LA	ΦM	ΦN	ΦP	T	ΦS	NO. OF HOLES
80	125	34	156	175	50	40	80	10	12	165	130	200	3.5	12	4
90L	140	36	176	190	56	50	90	10	12	165	130	200	3.5	12	4
100L	160	40	198	215	63	60	100	12	14	215	180	250	4	15	4
112M	190	45	226	236	70	60	112	12	14	215	180	250	4	15	4
132S	216	52	260	275	89	80	132	12	14	265	230	300	4	15	4
132M	216	52	260	275	89	80	132	12	14	265	230	300	4	15	4
160M	254	65	314	330	108	110	160	14.5	16	300	250	350	5	19	4
160L	254	65	314	330	108	110	160	14.5	16	300	250	350	5	19	4
180M	279	70	345	380	121	110	180	14.5	16	300	250	350	5	19	4
180L	279	70	345	380	121	110	180	14.5	18	300	250	350	5	19	4

DZA(S) THREE PHASE

Flanged motor aluminium

Features

Three-phase removable feet standard efficiency aluminium induction motors. Position of the terminal box can be changed according to the user's requirements. Efficiency indicator reaches IE1 standard.

Characteristics for all standard 3-phase aluminium induction motors are as follows:

1. IP55 protection, class F insulation, B temperature rise and S1 duty.
2. Rated voltage 400V or 525V, rated frequency 50Hz.
3. Y-connection for motors up to 3kW and Δ - connection for 4kW and above.
4. Cooling method is Ic411.

Operation conditions

Ambient temperature: -200C to 400C.



PERFORMANCE DATA

FRAME SIZE	POWER (kW)	RATED SPEED (rpm)	CURRENT FULL LOAD I_n (A)	FULL LOAD POWER FACTOR $\cos\phi$	EFFICIENCY $\eta\%$ OF % FULL LOAD			LOCKED ROTOR CURRENT I_s/I_n	LOCKED ROTOR TORQUE M_s/M_n	LOCKED ROTOR TORQUE M_k/M_n	BREAKDOWN TORQUE M_k/M_n	MOMENT OF INERTIA J(K-gm ²)	NETT WEIGHT kg
					100	75	50						
80	1.1	2830	2.5	0.84	74.3	77.0	77.3	7.0	2.2	2.8	0.0014	11	
90L	1.5	2840	3.3	0.85	76.5	78.7	79.3	7.0	2.2	2.8	0.0014	13.2	
90L	2.2	2840	4.67	0.85	80.0	80.8	79.5	7.0	2.5	2.8	0.0014	14.0	
100L	3	2870	6.07	0.87	82.0	82.1	80.3	7.5	2.2	2.5	0.0029	20.5	
112M	4	2880	7.81	0.88	84.0	84.8	84.1	7.5	2.3	2.3	0.0050	26.0	
132S	5.5	2910	10.6	0.88	85.0	85.0	83.5	7.5	2.2	2.5	0.0104	40.0	
132S	7.5	2905	14.3	0.88	86.3	86.6	85.6	7.5	2.2	2.4	0.0121	44.0	
132M	9.2/11	2910	20.3	0.89	87.8	87.4	85.9	7.5	2.2	2.4	0.0178	65.0	

Dimensions

FLANGE SPECIFICATION: B5

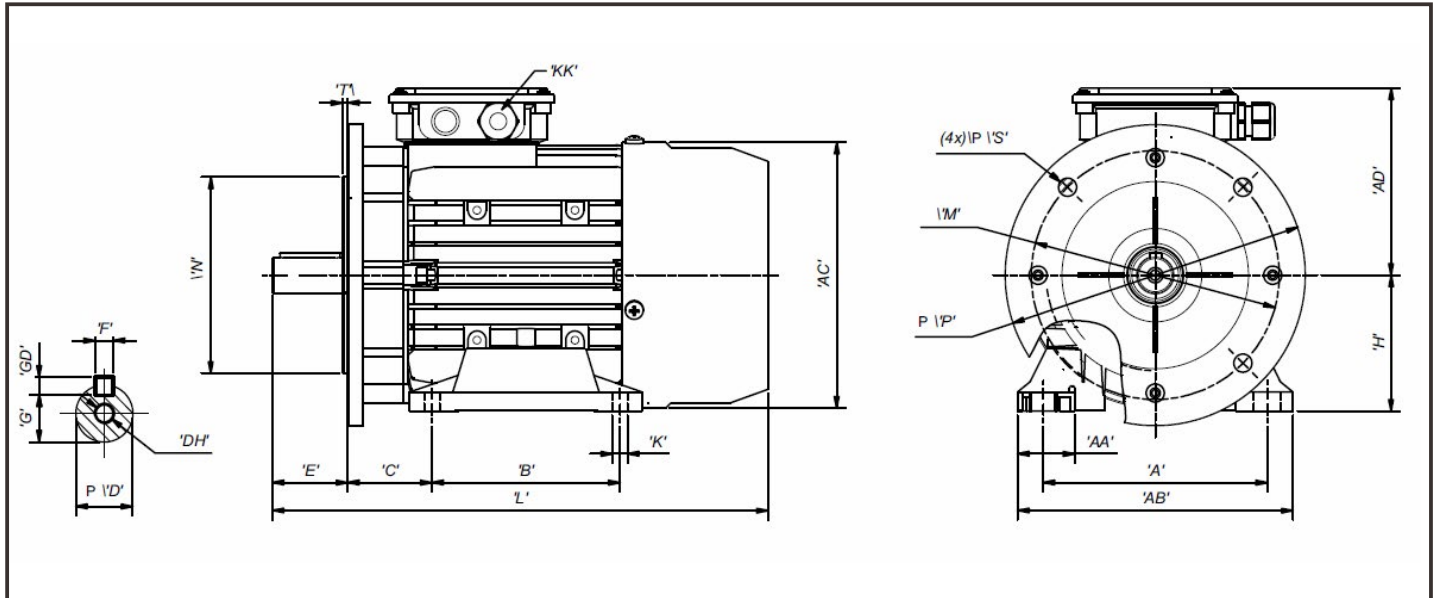

FRAME SIZE	kW	MOUNTING DIMENSIONS (mm)															
		AC	AD	D	DH	E	F	G	GD	KK	L	M	N	P(max)	S(min)	T	kg
80	1.1	165	100	19	M6X16	40	6	15.5	6	M25X1.5	310	165	130	200	12	3.5	13.63
90L	2.2	175	123	24	M8x19	50	8	27	7	M20x1.5	330	165	130	200	12	3.5	14.0
100L	3.0	196	139	28	M10x22	60	8	31	7	M20x1.5	370	215	180	250	15	4	20.5
112M	4.0	220	156	28	M10x22	60	8	31	7	M25x1.5	395	215	180	250	15	4	26.0
132S	5.5	260	185	38	M12x28	80	10	41	8	M25x1.5	472	265	230	300	15	4	40.0
132S	7.5	260	185	38	M12x28	80	10	41	8	M25x1.5	472	265	230	300	15	4	44.0
132M	9.2/11	260	185	38	M12x28	80	10	41	8	M25x1.5	510	265	230	300	15	4	65.0