

SUBMERSIBLE ACCESSORIES

DUCK FOOT ASSEMBLY



TRACER PUMPS

LEADING IN MOTION

24-01

SUBMERSIBLE RANGE

Accessories - Duck foot Assembly



This duck foot assembly accommodates the Vega sewage pumps for fixed installations. It is a rigid, cast iron connection system that connects to the sewage discharge line and ensures easy removal of the pump for maintenance. The duck foot creates a fixed positive seal with the pump's discharge without the use of a flexible hose. It is made of cast iron and consists of a top bracket, sliding foot and duck foot bend. Guide rails are excluded. Note however that the 50mm duck foot requires a 1" thick guide rail, whereas duck foot sizes from 80mm to 200mm need 1.5" thick guide rails.

50MM DUCK FOOT ASSEMBLY

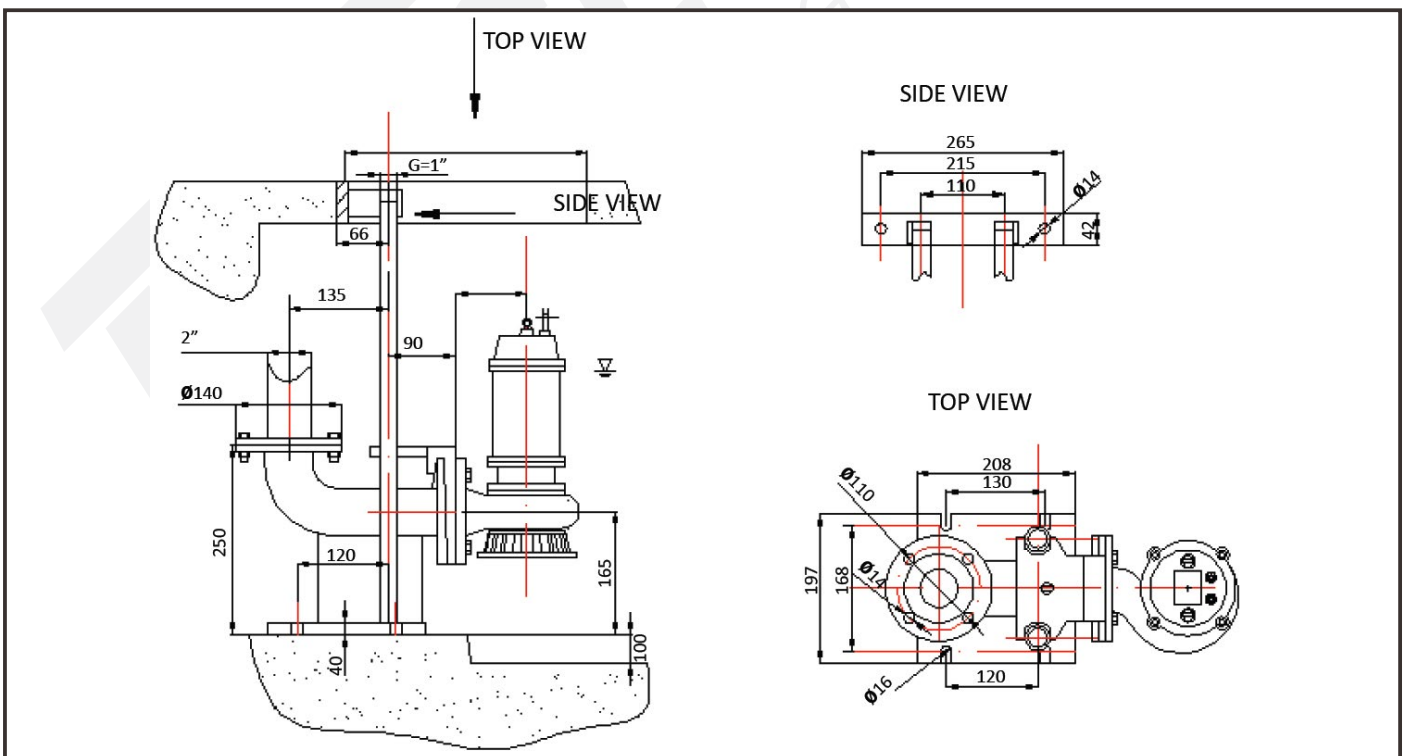

80mm DUCK FOOT ASSEMBLY

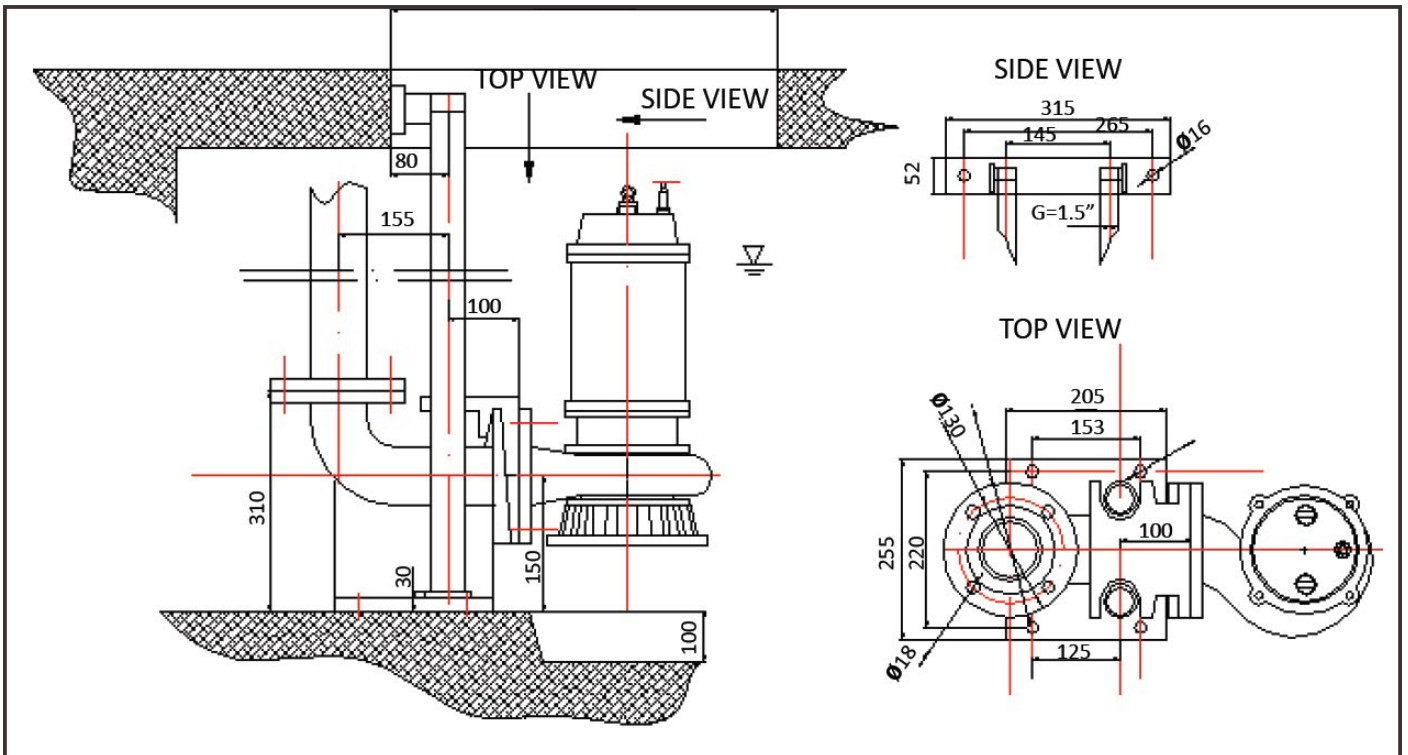

100mm DUCK FOOT ASSEMBLY

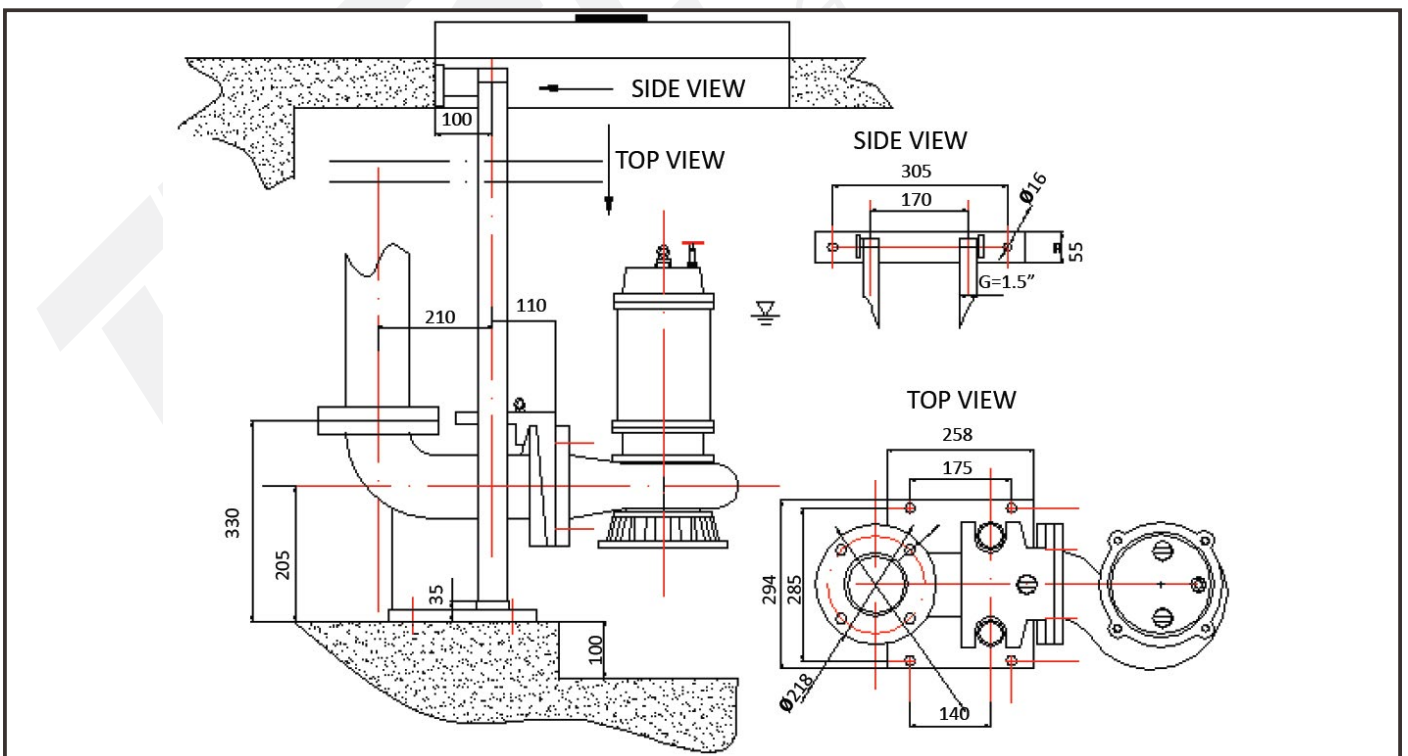

150mm DUCK FOOT ASSEMBLY

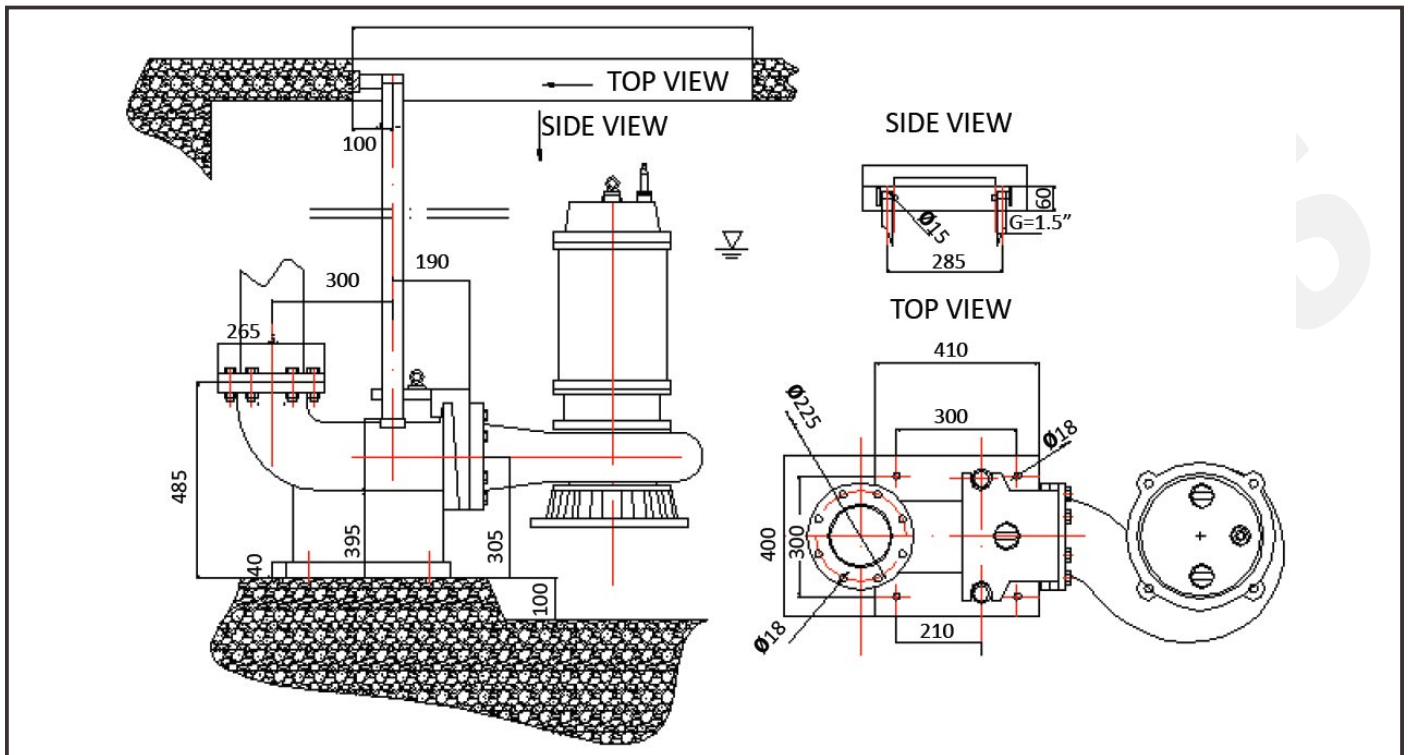

200mm DUCK FOOT ASSEMBLY

