

VERTICAL MULTI-STAGE RANGE

DL



TRACER PUMPS

LEADING IN MOTION

24-01

DL VERTICAL

Multi-Stage Pump

Applications

Used for water supply: water filter and transport in water works, boosting of main pipeline, boosting in high-rise building.

For industrial boosting: process flow water system, cleaning system, high-pressure washing system, fire fighting system.

For industrial liquid conveying: cooling and air-condition system, feed water for boiler and condensing system, machine-associated purpose, acids and alkali.

For water treatment: ultra-filtration system, reverse osmosis system, distillation system, separator and swimming pools.

For irrigation: farmland irrigation, spray irrigation and dripping irrigation.

Operating conditions

Thin, clean, non-explosive liquid containing no solid granules or fibres.

Liquid temperature:

Normal type: -15 to +110 0C.

Motor

2-pole induction motor

Aluminium alloy motor case

Insulation class F

Protection IP55

Continuous duty

Technical features

Performance Range Head:	up-to 250m
Flow:	1 - 90 m ³ /h
Power:	0.37 to 45 kW
Liquid Temperature Limits:	-15 to +110 0C
Working Pressure:	20-26 Bar

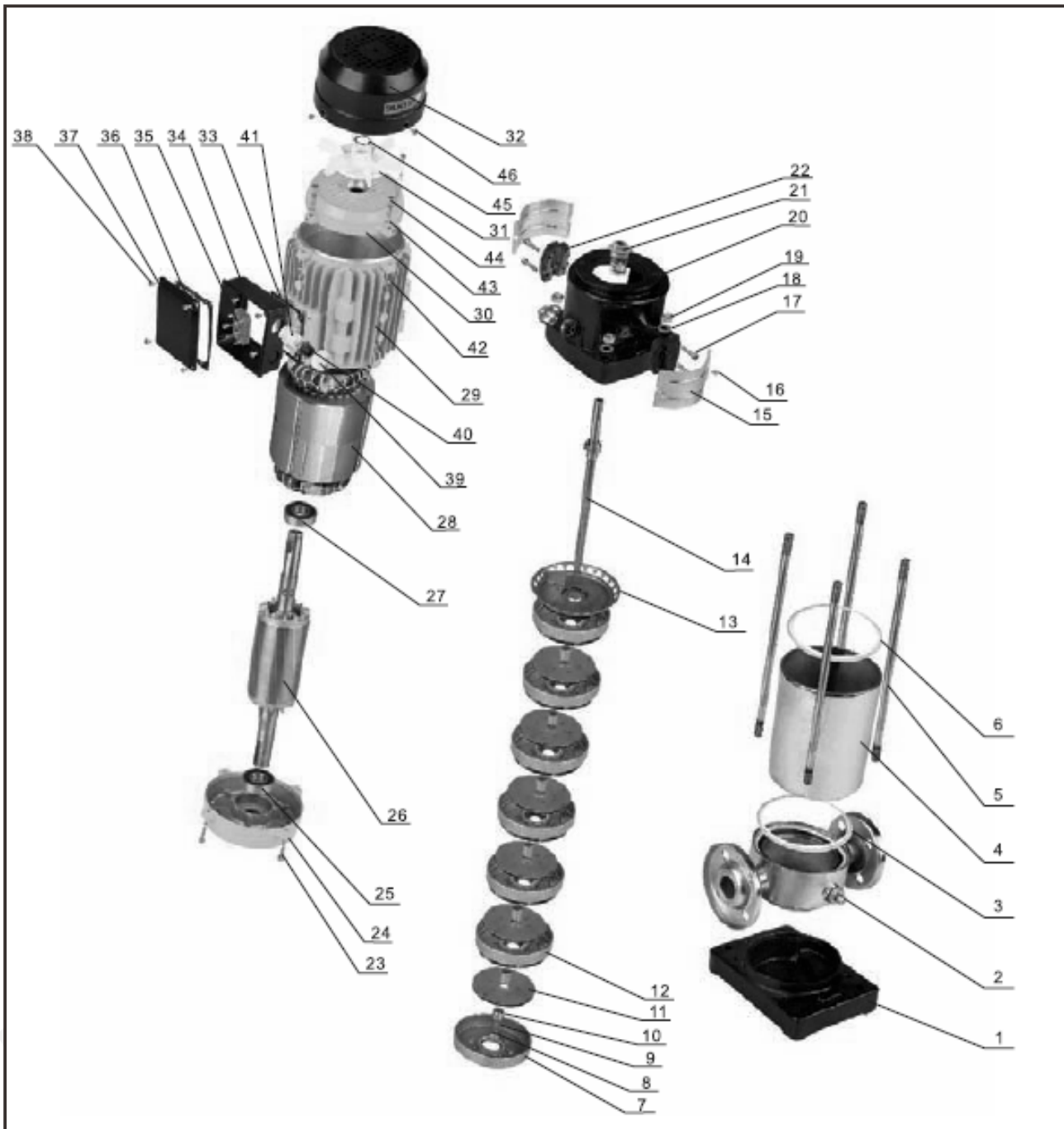

No.	Description	No.	Description	No.	Description	No.	Description	No.	Description
1	Pump Base	11	Impeller	21	Mechanical Seal	31	Fan	41	Terminal Box Screw Stopper
2	Pump Body	12	Diffuser	22	Shaft Connector	32	Fan Cover	42	Nut
3	Seal Washer	13	End Segment	23	Bolt	33	Terminal Base Seal	43	Washer
4	S/S Canister	14	Pump Shaft	24	Motor Cover	34	Terminal Base	44	Bolt
5	Bolt	15	Shield	25	Bearing	35	Terminal Block	45	Snap Ring
6	Seal Washer	16	Screw	26	Rotor	36	Terminal Box Seal	46	Screw
7	First Segment	17	Bolt	27	Bearing	37	Terminal Box Cover		
8	Nut	18	Washer	28	Stator	38	Screw		
9	Washer	19	Nut	29	Motor Body	39	Terminal Box Screw Shield		
10	Impeller Shield	20	Motor Bracket	30	End Cover	40	Cable Seal		

Model number descriptions

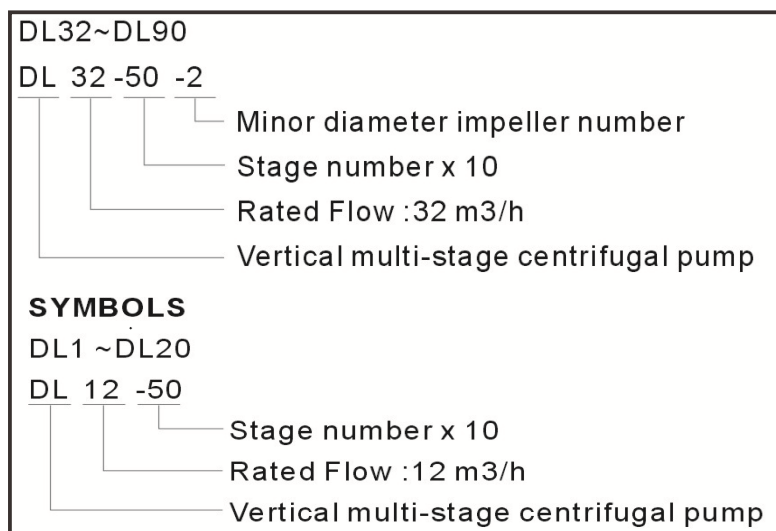

Performance data

		RANGE										
		DL1	DL3	DL5	DL8	DL12	DL16	DL20	DL32	DL45	DL64	DL90
RATED CURRENT	(m ³ /h)	1	3	5	8	12	16	20	32	45	64	90
FLOW LIMITATION	(m ³ /h)	0.6-2.0	1.2-4.0	3-8	5-12	7-16	8-22	10-28	16-40	25-55	30-80	50-120
MAX. OPERATING PRESSURE	(bar)	25	25	25	25	25	25	25	30	30	30	30
MOTOR POWER	(kW)	0.37 - 1.5	0.37 - 2.2	0.37 - 4	0.75 - 7.5	1.5 - 11	2.2 - 15	2.2 - 18.5	1.5 - 30	3.0 - 45	4.0 - 45	5.5 - 45
LIQUID TEMPERATURE	(°C)	-15 to +110										
MAXIMUM EFFICIENCY	(%)	48	57	62	69	63	69	70	76	78	76	75
NOMINAL DIAM. OF FLANGE		DN25 (1")	DN25 (1")	DN32 (1¼")	DN40 (1½")	DN40 (1½")	DN50 (2")	DN50 (2")	DN65 (2½")	DN80 (3")	DN80 (3")	DN100 (4")

This data was obtained using a 2 pole, 50Hz standard motor at 2900rpm. Water temperature: 20°C. Performance limits are according to ISO 2548. Specification for standard class C pumps & GB3216-2005 specification for standard class 2 pumps.

To avoid overload and damage, the pump should be operated within these performance ranges.

PERFORMANCE CURVE

Descriptions

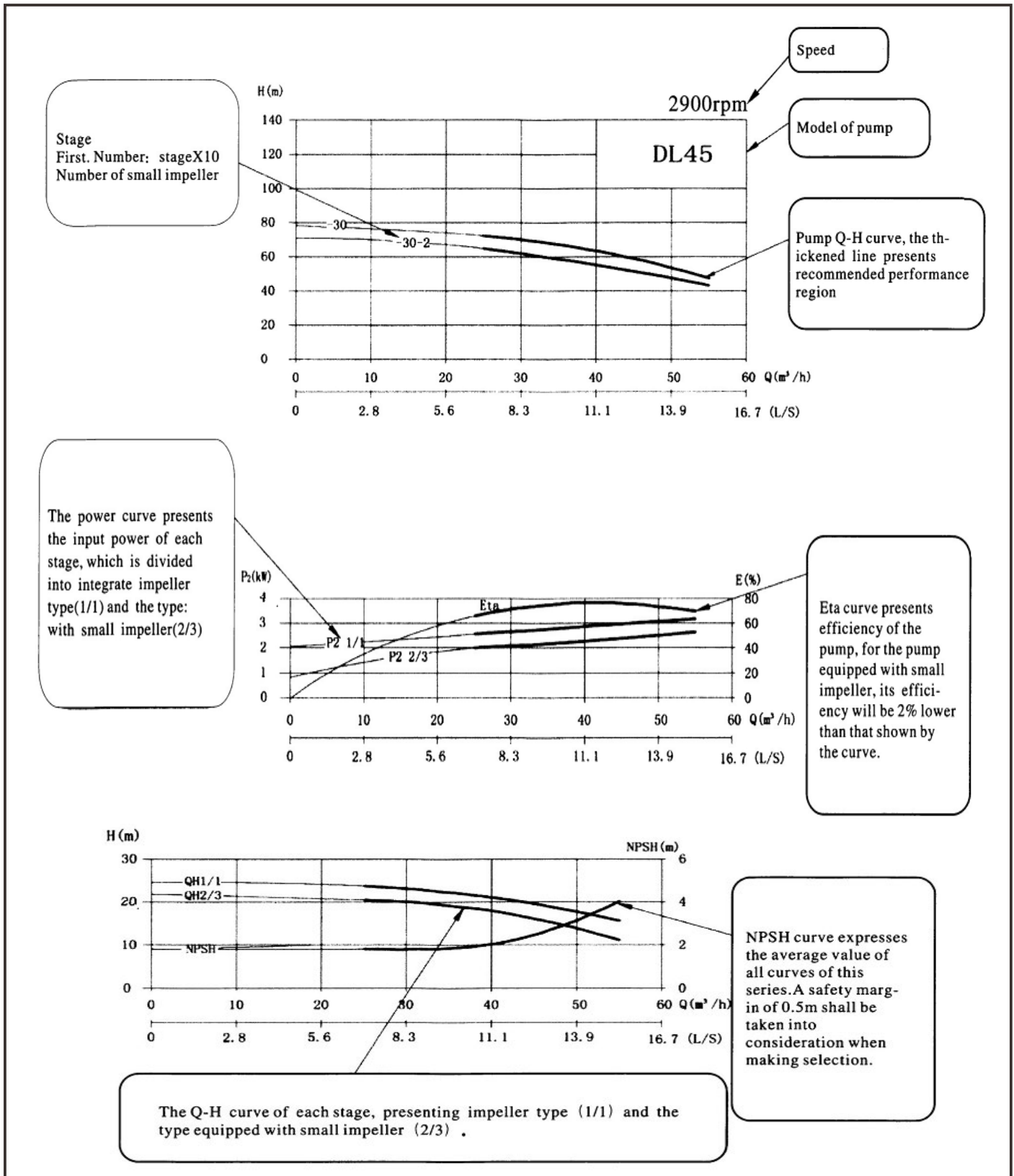

This data was obtained at 2900rpm. Curve tolerance conforms with ISO9006. Water was air free, at 20°C, kinematic velocity of 1mm²/sec. The performance range is indicated by the thickened part on the curve. This performance range will prevent overloading and overheating.

SUCTION HEAD

Measurement

When the pump is operated under the following conditions, it is necessary to measure the suction pressure:

- High liquid temperature
- Actual capacity is clearly more than the rated capacity
- Suction head is too high
- Suction pipe is too long
- Bad suction conditions

If the pump suction pressure is lower than the steam pressure of the transported liquid, vapour may occur. To avoid this ensure that there is minimum pressure at the pump's suction end.

Maximum Suction Head can be calculated as follows:

$$H = P_b \times 10.2 - NPSH - H_f - H_v - H_s$$

P_b Atmospheric pressure (bar). In a closed system, this represents system pressure.

NPSH Net Positive Suction Head (m). Refer to performance curve.

H_f Loss of suction pump (m)

H_v Vapour Pressure (m)

H_s Safety allowance (min. = 0.5m head)

If H is a positive value, the pump can be operated with the maximum suction head.

If H is a negative value, a minimum suction pressure (of positive "H"m head) is required.

An example where fresh water is being transported:

- P_b: 1bar
- Pump model: DL2, 50Hz
- Flow: Q=2m³/h
- NPSH: 1.5m (see pump's curve)
- H_f: 3m
- Liquid temperature: 80°C
- H_v: 4.8 (see figure alongside)

$$H = P_b \times 10.2 - NPSH - H_f - H_v - H_s$$

$$H = 1 \times 10.2 - 1.5 - 3 - 4.8 - 0.5 = 0.4m$$

This means that the pump can be operated at a maximum suction head of 0.4m.

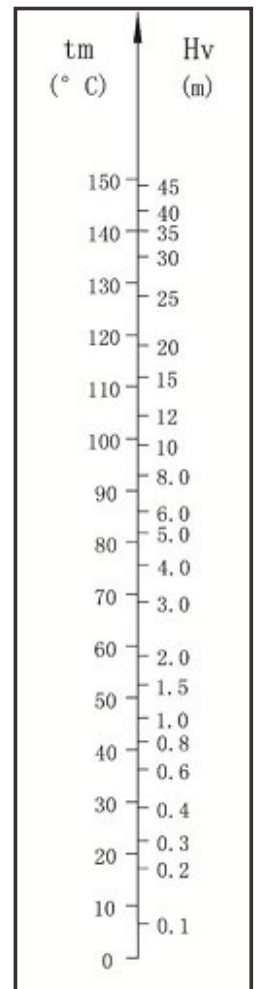
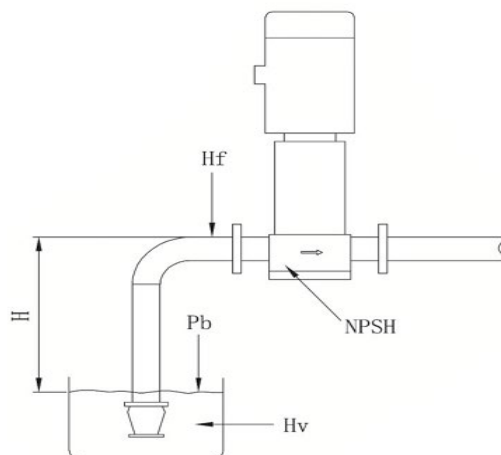

SPARE PARTS

DL1-5

NUMBER	DESCRIPTION	MATERIAL
1	Motor	
2	Coupling	Cast Steel
3	Bracket	Cast Iron
4	Mechanical Seal	Carbon/TCT/Viton
5	Back Cover	SUS304
6	Pump Shaft	SUS304/SUS431
7	Tension Bar	SUS304
8	Impeller	SUS304
9	Diffuser Assembly	SUS304
10	Plain Bearing	SiC/TC
11	Outer Barrel	SUS304
12	Bottom Cover	SUS304
13	Base Plate	Cast Iron HT200

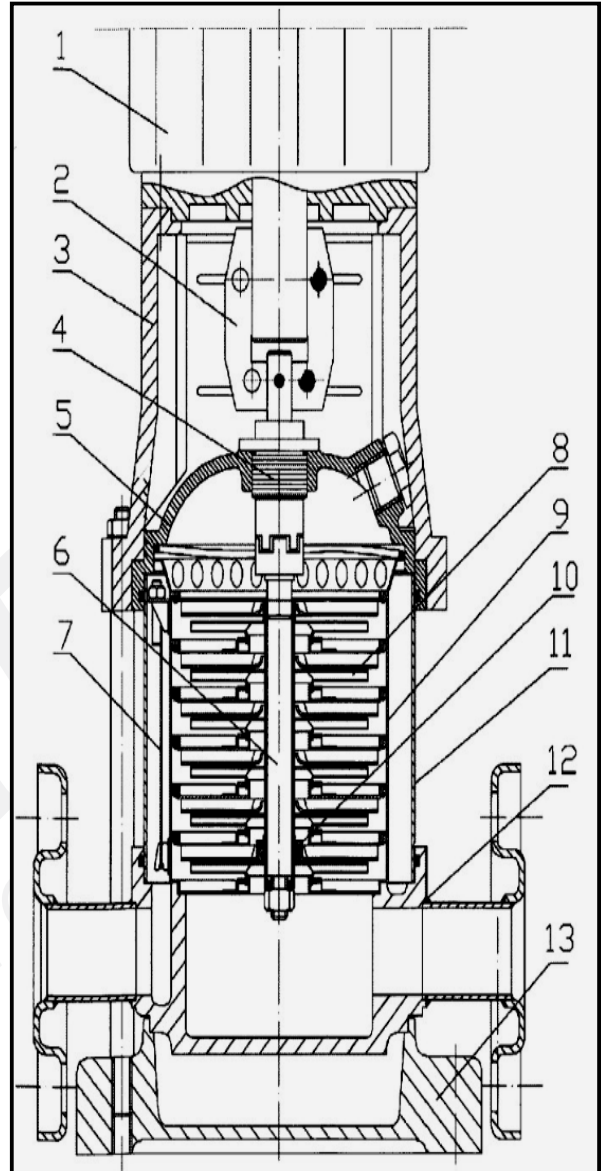

SPARE PARTS

DL8-20

NUMBER	DESCRIPTION	MATERIAL
1	Motor	
2	Coupling	Cast Steel
3	Bracket	Cast Iron
4	Mechanical Seal	Carbon/TCT/Viton
5	Back Cover	SUS304
6	Pump Shaft	SUS304/SUS431
7	Tension Bar	SUS304
8	Impeller	SUS304
9	Diffuser Assembly	SUS304
10	Outer Barrel	SUS304
11	Plain Bearing	SiC/TC
12	Plain Bearing	SUS304
13	Bottom Cover	SUS304
14	Base Plate	Cast Iron HT200

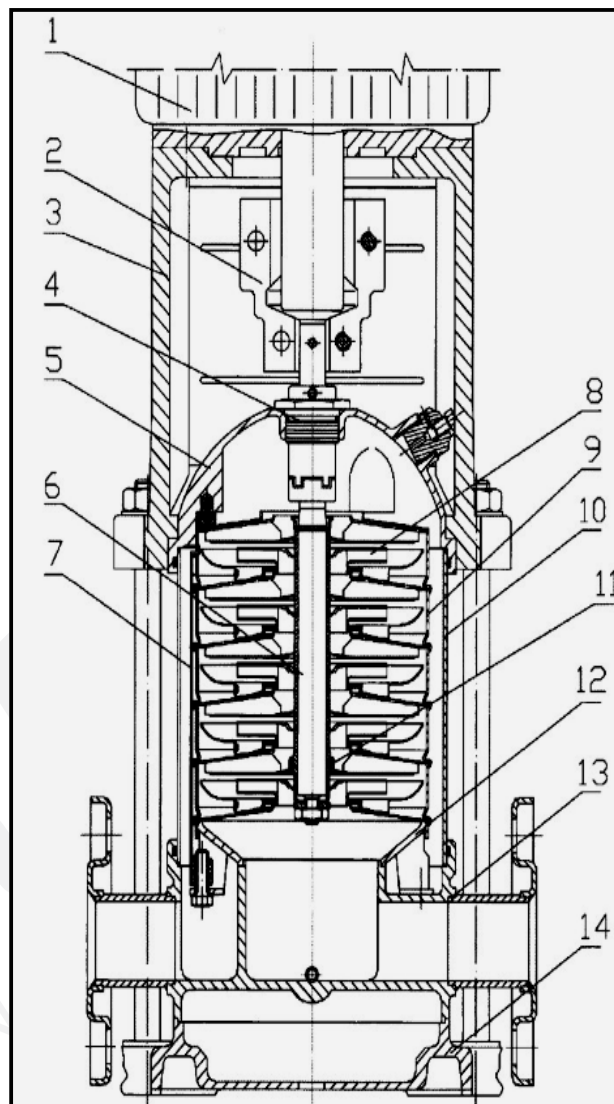

SPARE PARTS

DL32-90

NUMBER	DESCRIPTION	MATERIAL
1	Motor	
2	Coupling	Cast Steel
3	Bracket	Cast Iron
4	Mechanical Seal	Carbon/TCT/Viton
5	Back Cover	SUS304
6	Pump Shaft	SUS304/SUS431
7	Tension Bar	SUS304
8	Impeller	SUS304
9	Diffuser Assembly	SUS304
10	Outer Barrel	SUS304
11	Plain Bearing	SiC/TC
12	Bottom Cover	SUS304
13	Base Plate	Cast Iron HT200
14	Flange	Cast Steel 45*

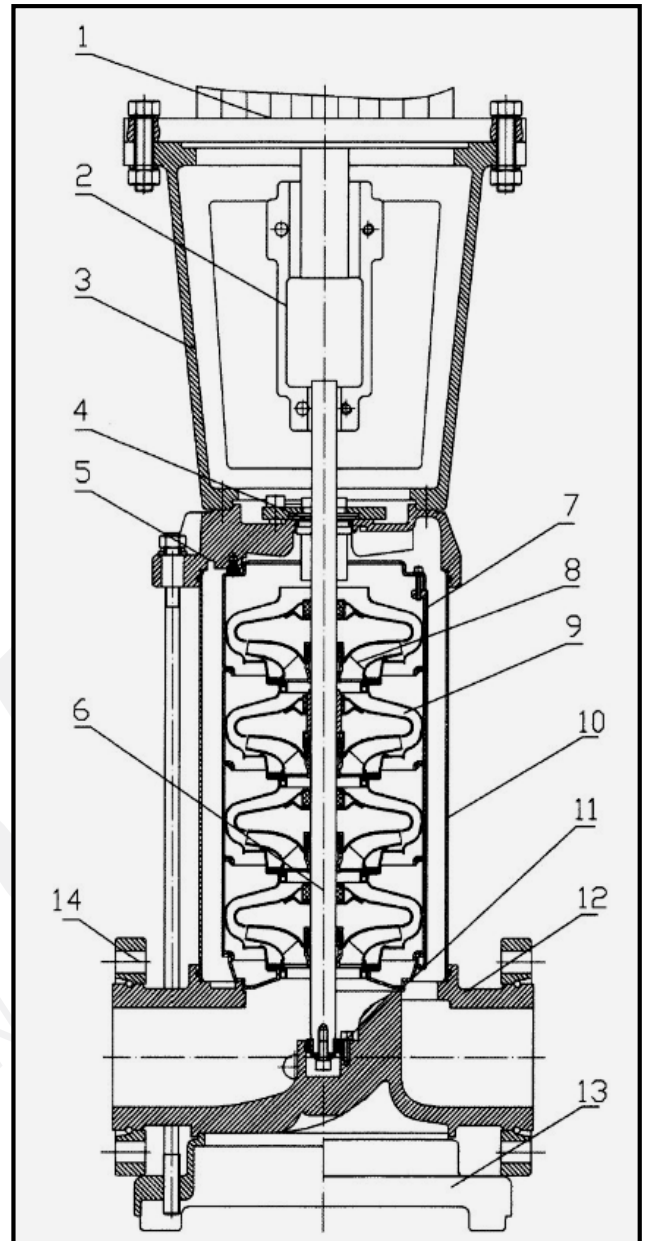

PERFORMANCE CURVES

DL1

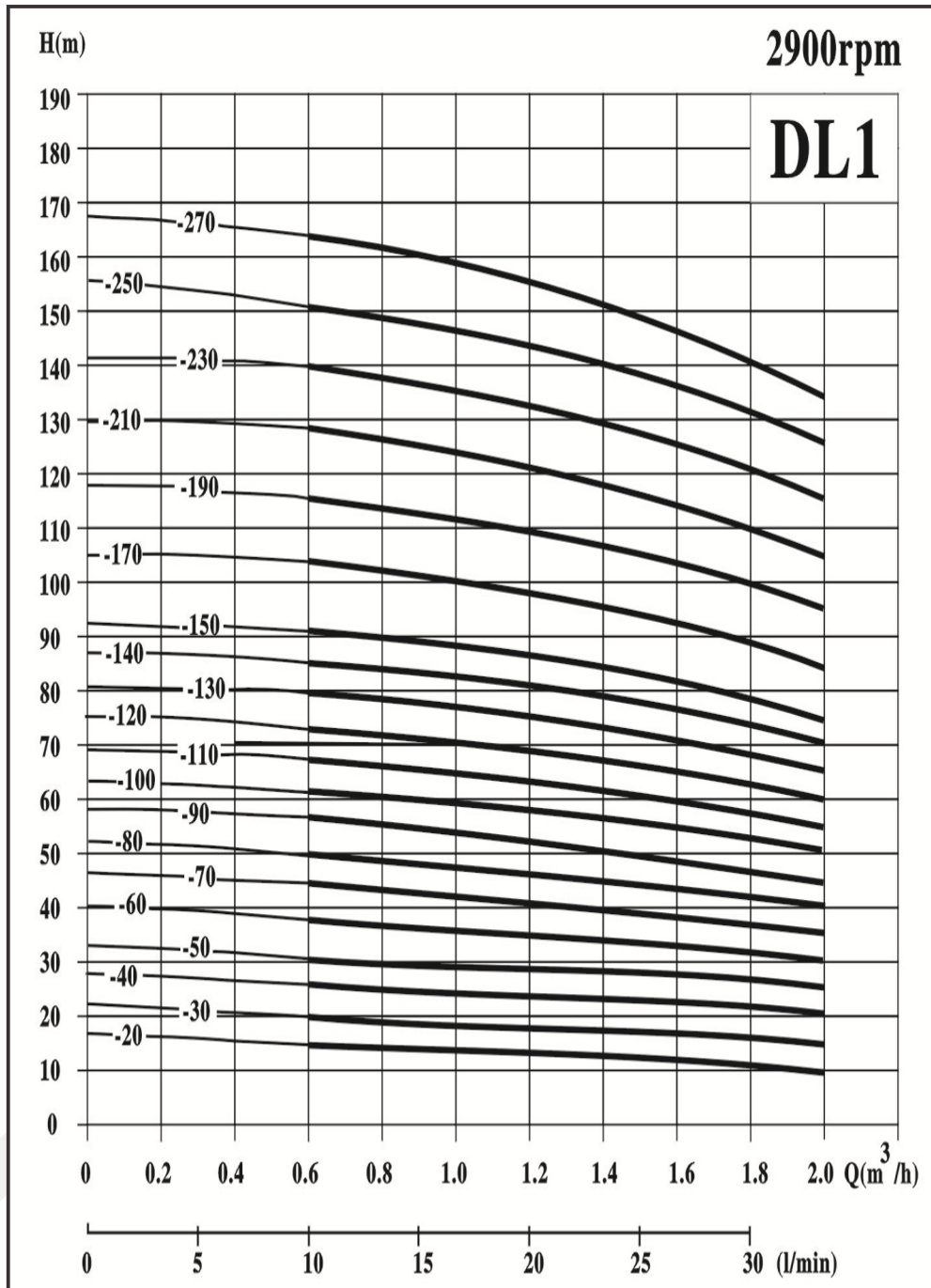

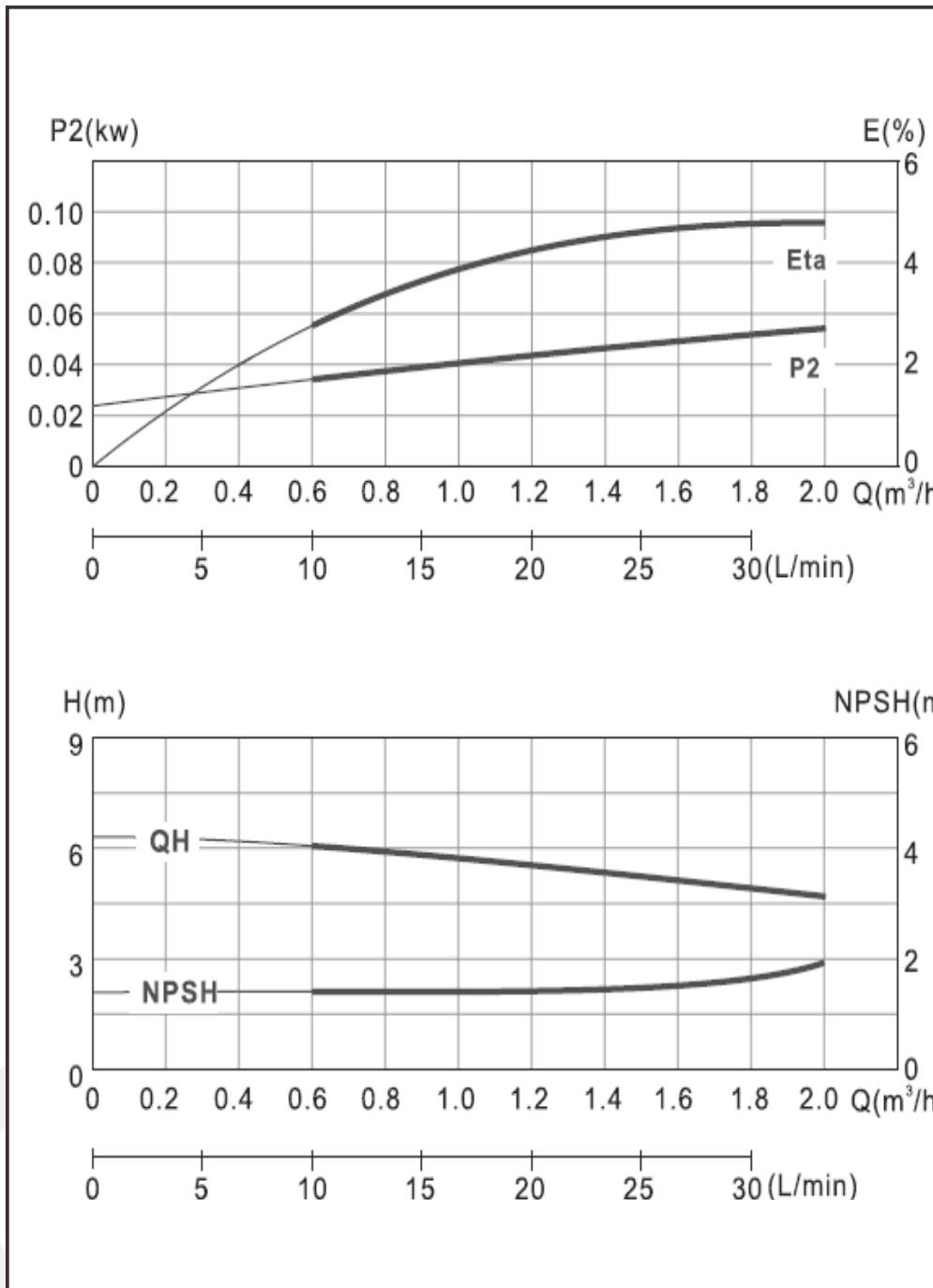

PERFORMANCE TABLE

DL1

MODEL	POWER		CAPACITY									
	3 Phase 380V 50Hz	kW	HP	m ³ /h	0.4	0.6	0.8	1.0	1.2	1.4	1.6	1.8
l/min				6.7	10	13.3	16.7	20	23.3	26.7	30	33.3
DL1-20	0.37	0.5	Head (m)	13	12.5	12	11.5	11	10.5	10	9.5	9
DL1-30	0.37	0.5		18	17.5	17	16.5	16	15.5	15	14.5	14
DL1-40	0.37	0.5		24	23.5	23	22.5	22	21.5	21	20	19
DL1-50	0.37	0.5		30	29.5	29	28.5	28	27	26	25	24
DL1-60	0.37	0.5		36	35.5	35	34	33	32	31	30	28
DL1-70	0.37	0.5		42.5	42	41	40	39	38	37	35	33
DL1-80	0.55	0.75		48.5	47	46	45	44	43	42	40	38
DL1-90	0.55	0.75		54.5	54	53	52	50	49	47	45	43
DL1-100	0.55	0.75		60.5	60	59	57.5	56	54	52.5	50	47
DL1-110	0.55	0.75		67	65.5	64	62.5	61	60	57.5	55	52
DL1-120	0.75	1.0		73	71.5	70	68.5	67	65	63	60	56
DL1-130	0.75	1.0		79	77.5	76	74.5	72	70.5	68	65	61
DL1-140	0.75	1.0		85	83	81	79	78	76	73.5	70	66
DL1-150	0.75	1.0		91	89	87	85	83	81	79	75	71
DL1-170	1.1	1.5		103	101	99	97	94	92	89	85	80
DL1-190	1.1	1.5		115	113	111	109	106	103	99.5	95	90
DL1-210	1.1	1.5		127	125	123	121	117	114	110	105	99
DL1-230	1.1	1.5		139	137	135	133	128	125	120	115	108
DL1-250	1.5	2.0		151	149	146	144	140	136	131	125	118
DL1-270	1.5	2.0		163	161	158	156	150	147	141	135	127

PUMP DIMENSIONS

MODEL	DIMENSIONS (mm)						WEIGHT
	B1	B2	B1+B2	D1	D2	D3	
DL1-20	277	217	494	140	104	105	18
DL1-30	295	217	512	140	104	105	18
DL1-40	313	217	530	140	104	105	18
DL1-50	331	217	548	140	104	105	18
DL1-60	349	217	566	140	104	105	18
DL1-70	367	217	584	140	104	105	18
DL1-80	385	217	602	140	104	105	20
DL1-90	403	217	620	140	104	105	20
DL1-100	421	217	638	140	104	105	22
DL1-110	439	217	656	140	104	105	22
DL1-120	457	267	724	159	113	120	25
DL1-130	475	267	742	159	113	120	25
DL1-140	493	267	760	159	113	120	25
DL1-150	511	267	778	159	113	120	25
DL1-170	547	267	814	159	113	120	25
DL1-190	583	267	850	159	113	120	27
DL1-210	619	267	886	159	113	120	27
DL1-230	665	267	932	159	113	120	27
DL1-250	719	281	1000	177	122	140	30
DL1-270	737	281	1018	177	122	140	30

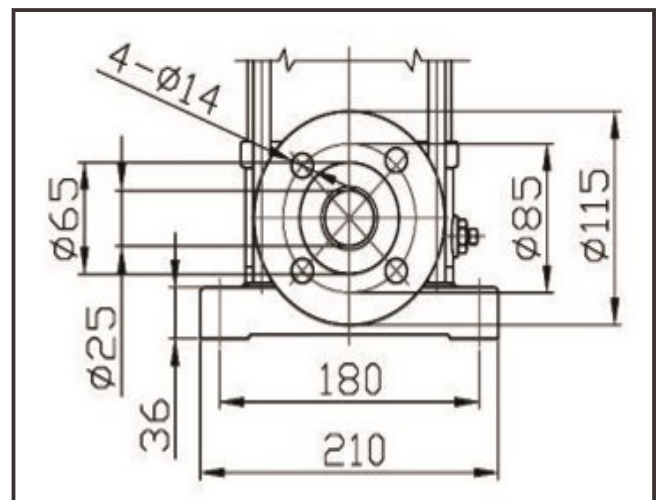
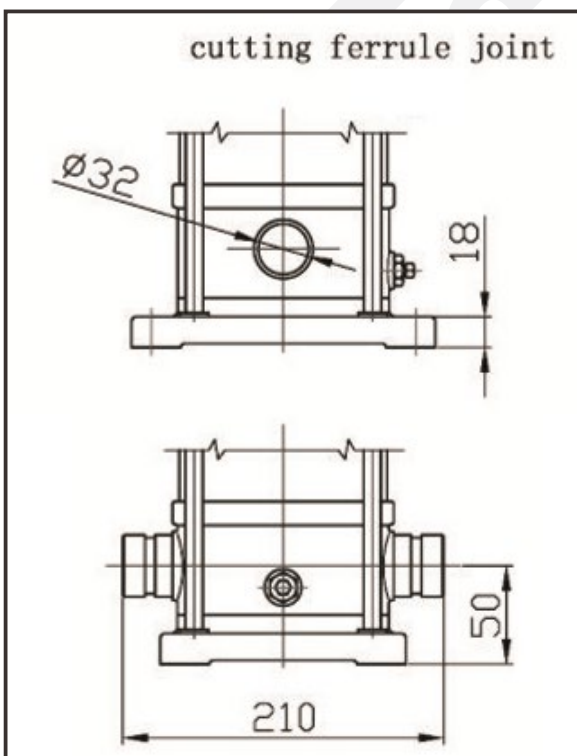
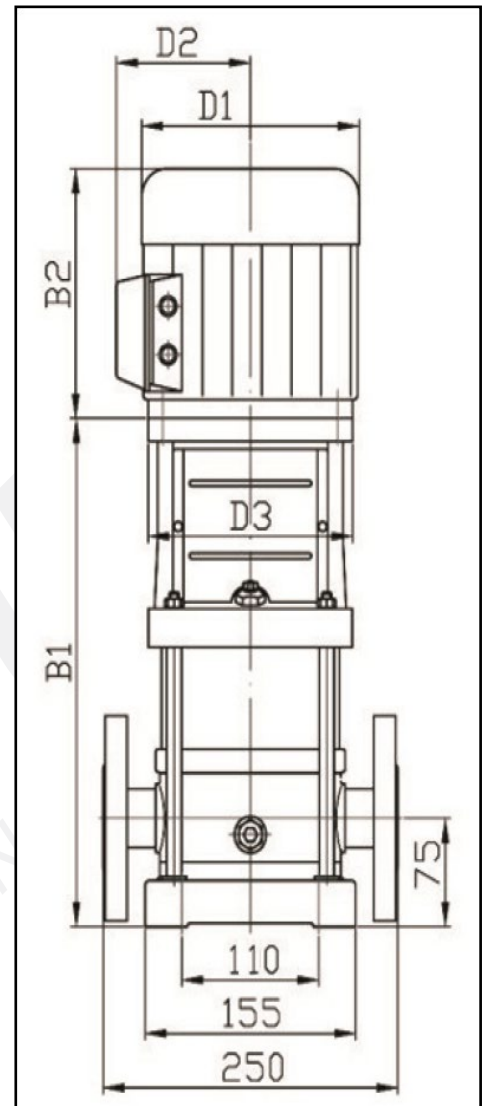

PERFORMANCE CURVES

DL3

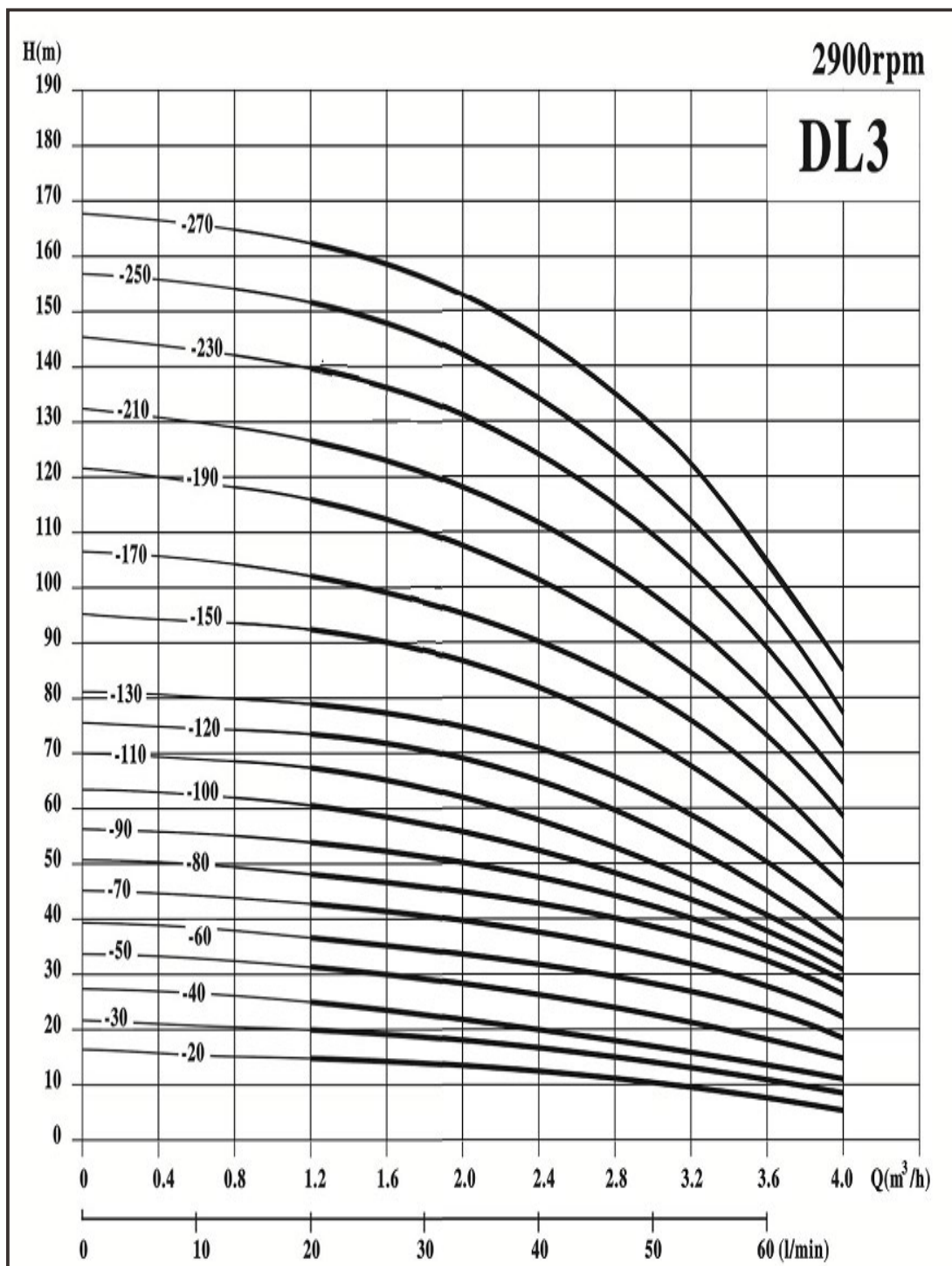

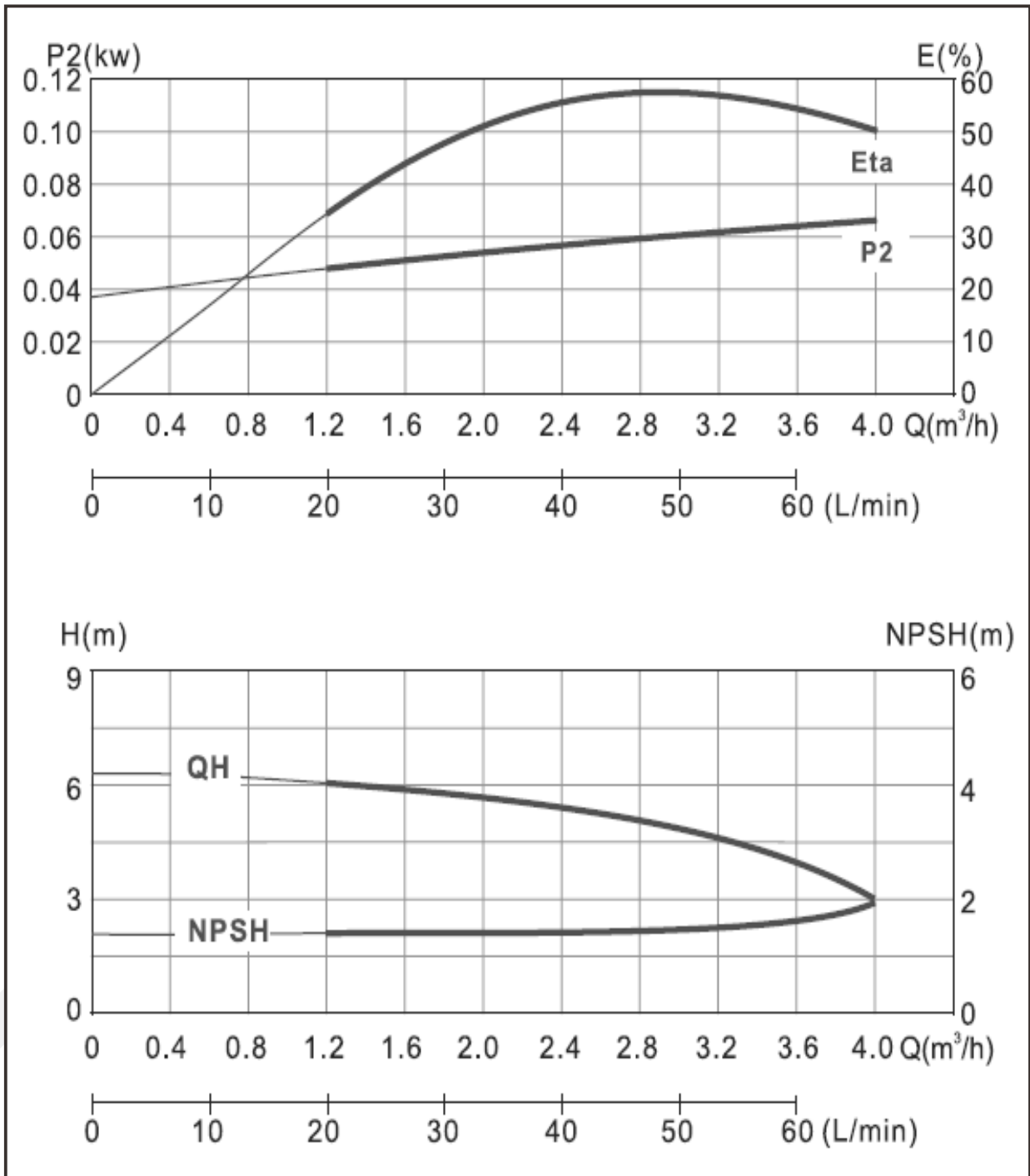

PERFORMANCE TABLE

DL3

MODEL	POWER		CAPACITY									
	kW	HP	m ³ /h	1.2	1.6	2.0	2.4	2.8	3.0	3.2	3.6	4.0
3 Phase 380V 50Hz				l/min	20	26.7	33.3	40	46.7	50	53.3	60
DL3-20	0.37	0.5	Head (m)	12	11.5	11	10.5	10	9.5	9	7.5	6
DL3-30	0.37	0.5		18	17	16.5	15.5	15	14	13	11	9
DL3-40	0.37	0.5		24.5	23	22.5	21	20	18.5	17	15	12
DL3-50	0.37	0.5		30	29	28	26.5	25	23	21	19	15
DL3-60	0.55	0.75		37	35	34	32	30	28	26	23	18
DL3-70	0.55	0.75		43	41.5	40	37	35	33	31	27	21
DL3-80	0.75	1.0		49	47.5	46	42.5	40	38	36	31	25
DL3-90	0.75	1.0		55	53	51.5	48	45	43	41	35	28
DL3-100	0.75	1.0		61	59	56.5	53	50	47	44	38	31
DL3-110	0.75	1.0		67	64.5	62	58	55	52	48	42	34
DL3-120	1.1	1.5		73	70	68	63.5	60	57	53	46	37
DL3-130	1.1	1.5		79	76	74	69	65	62	58	50	40
DL3-150	1.1	1.5		92	88	86	80	75	71	67	58	46
DL3-170	1.5	2.0		103	100	97	90	85	81	76	65	52
DL3-190	1.5	2.0		116	112	108	101	95	90	85	73	58
DL3-210	2.2	3.0		128	124	120	112	105	100	94	81	65
DL3-230	2.2	3.0		140	135	131	122	115	110	103	89	71
DL3-250	2.2	3.0		152	147	142	133	125	120	111	97	77
DL3-270	2.2	3.0	165	159	154	144	135	129	120	105	84	

PUMP DIMENSIONS

MODEL	DIMENSIONS (mm)						WEIGHT
	B1	B2	B1+B2	D1	D2	D3	
DL3-20	277	217	494	140	104	105	26
DL3-30	295	217	512	140	104	105	26
DL3-40	313	217	530	140	104	105	26
DL3-50	331	217	548	140	104	105	26
DL3-60	349	217	566	140	104	105	29
DL3-70	367	217	584	140	104	105	29
DL3-80	385	267	652	159	113	120	32
DL3-90	403	267	670	159	113	120	32
DL3-100	421	267	688	159	113	120	32
DL3-110	439	267	706	159	113	120	34
DL3-120	457	267	724	159	113	120	34
DL3-130	475	267	742	159	113	120	36
DL3-150	511	267	778	159	113	120	36
DL3-170	547	281	828	177	122	140	39
DL3-190	583	281	864	177	122	140	39
DL3-210	619	281	900	177	122	140	42
DL3-230	665	281	946	177	122	140	42
DL3-250	719	281	1000	177	122	140	42
DL3-270	737	281	1018	177	122	140	42

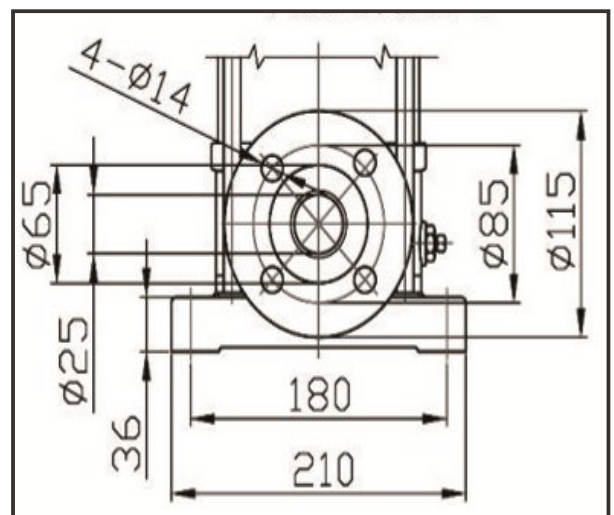
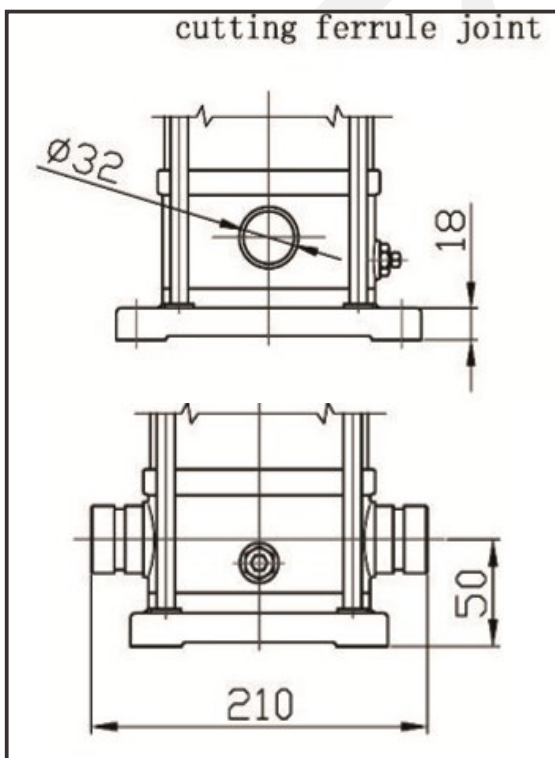
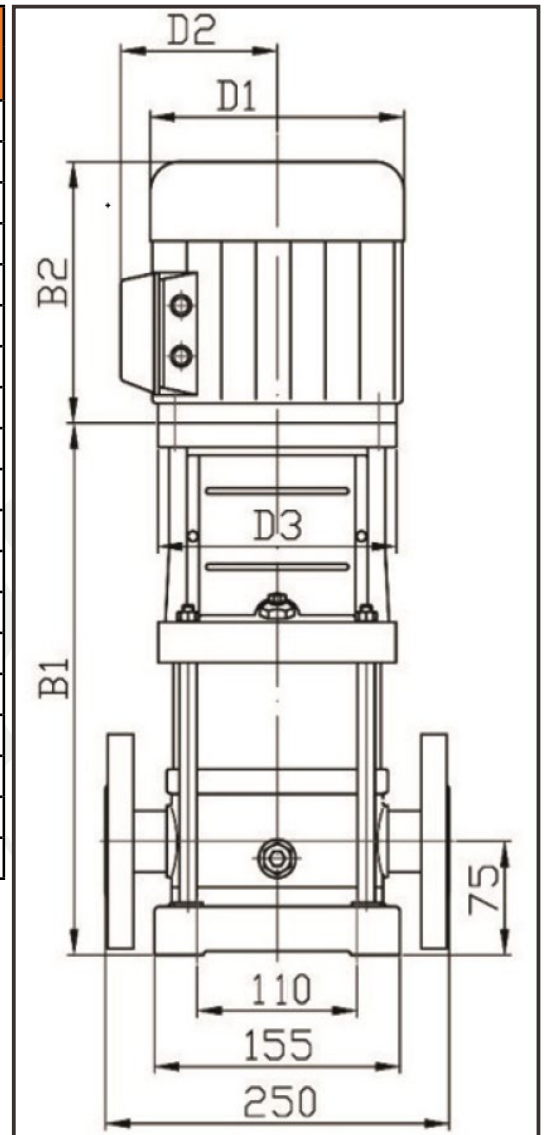

PERFORMANCE CURVES

DL5

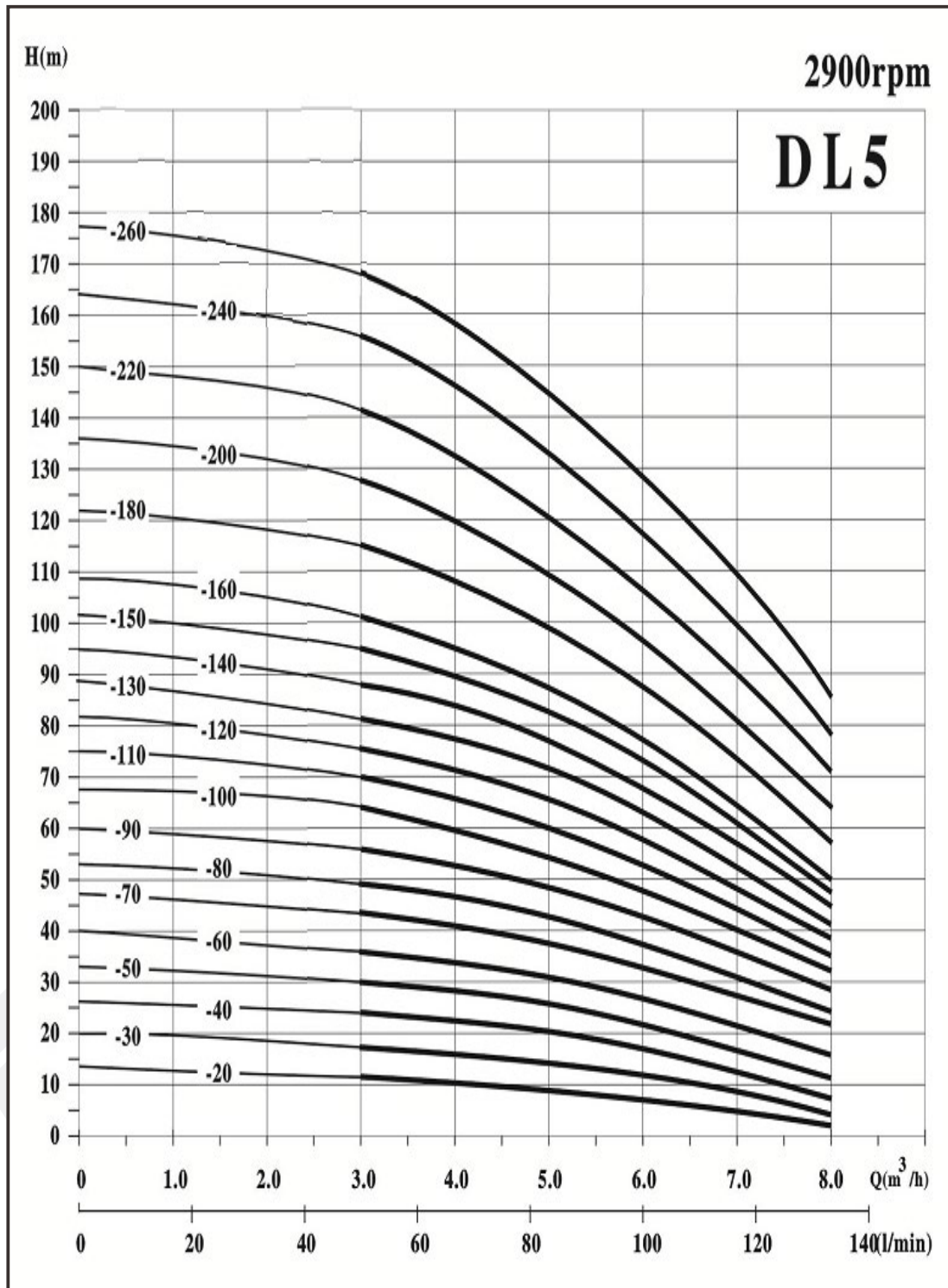

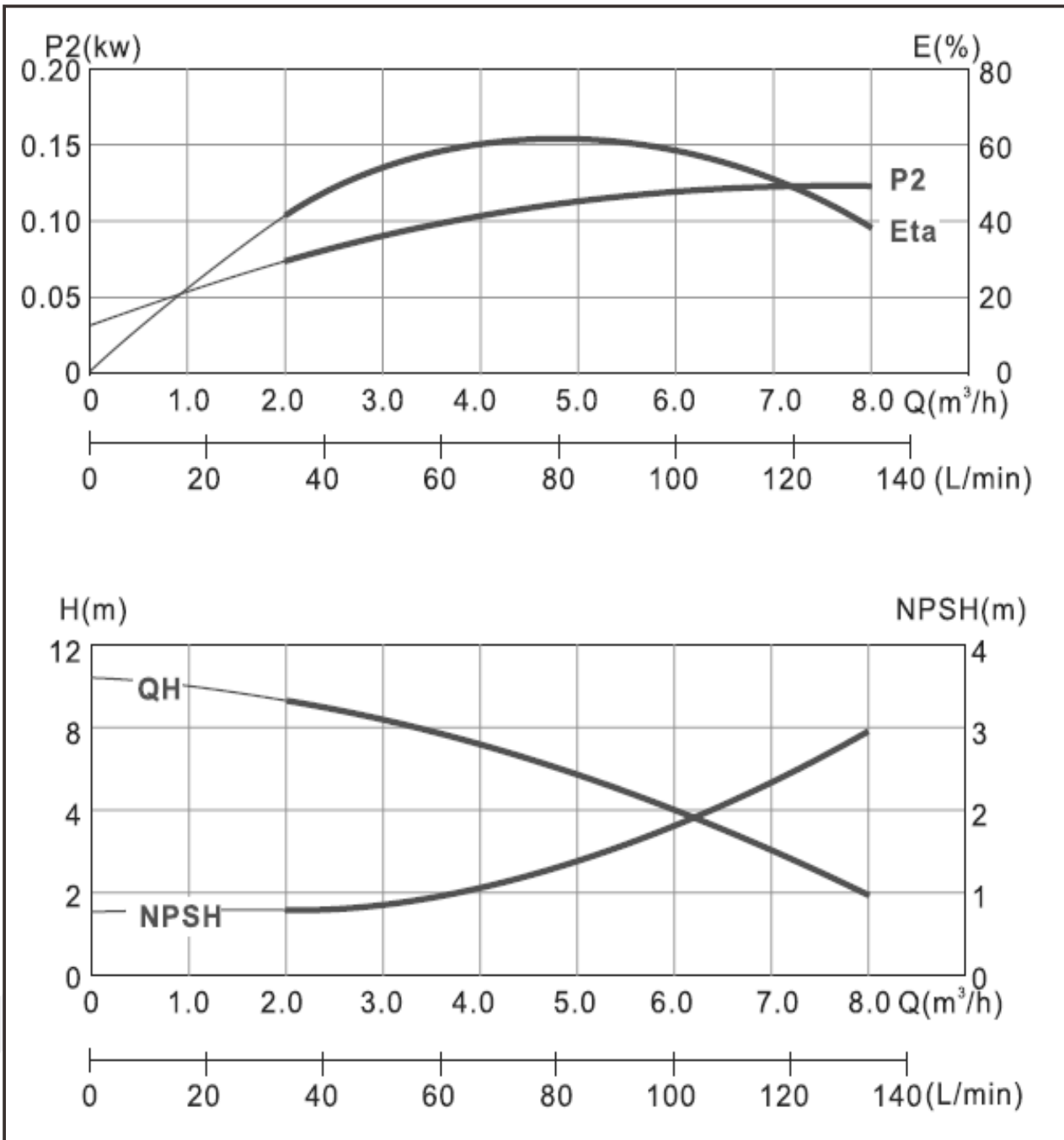

PERFORMANCE TABLE

DL5

MODEL	POWER		CAPACITY						
	kW	HP	m ³ /h	3	4	5	6	7	8
3 Phase 380V 50Hz				l/min	50	66.7	83.3	100	116.6
DL5-20	0.55	0.75	Head (m)	11	10	9	7	4	2
DL5-30	0.55	0.75		17	16	15	11	8	4
DL5-40	0.55	0.75		24	22	20	16	12	7
DL5-50	0.75	1.0		30	28	25	21	16	11
DL5-60	1.1	1.5		36	34	30.5	26	21	16
DL5-70	1.1	1.5		42	40	36	31	26	20
DL5-80	1.1	1.5		49	47	42	37	31	24
DL5-90	1.5	2.0		56	53	48	42	36	28
DL5-100	1.5	2.0		64	59	54	48	40	32
DL5-110	2.2	3.0		70	65	60	53	44	35
DL5-120	2.2	3.0		75	71	66	58	48	38
DL5-130	2.2	3.0		81	77	71.5	63	52	41
DL5-140	2.2	3.0		88	83	77	68	56	44
DL5-150	2.2	3.0		95	89	82	73	60	47
DL5-160	2.2	3.0		101	95	87	78	64	50
DL5-180	3.0	4.0		115	107	98	88	72	57
DL5-200	3.0	4.0		128	120	109	98	80	64
DL5-220	4.0	5.5		141	132	120	108	90	71
DL5-240	4.0	5.5		155	144	131	118	100	78
DL5-260	4.0	5.5		168	156	142	128	110	85

PUMP DIMENSIONS

MODEL	DIMENSIONS (mm)						WEIGHT
	B1	B2	B1+B2	D1	D2	D3	
DL5-20	295	217	512	140	104	105	23
DL5-30	322	217	539	140	104	105	26
DL5-40	349	217	566	140	104	105	26
DL5-50	376	267	643	159	113	120	30
DL5-60	403	267	670	159	113	120	33
DL5-70	430	267	697	159	113	120	33
DL5-80	457	267	724	159	113	120	33
DL5-90	484	281	765	177	122	140	33.5
DL5-100	511	281	792	177	122	140	33.5
DL5-110	538	281	819	177	122	140	38
DL5-120	565	281	846	177	122	140	38
DL5-130	592	281	900	177	122	140	38
DL5-140	619	281	900	177	122	140	38
DL5-150	646	281	927	177	122	140	38
DL5-160	673	281	954	177	122	140	38
DL5-180	737	328	1065	197	128	160	46.5
DL5-200	791	328	1119	197	128	160	46.5
DL5-220	845	307	1152	216	152	160	53
DL5-240	899	307	1206	216	152	160	53
DL5-260	953	307	1260	216	152	160	53

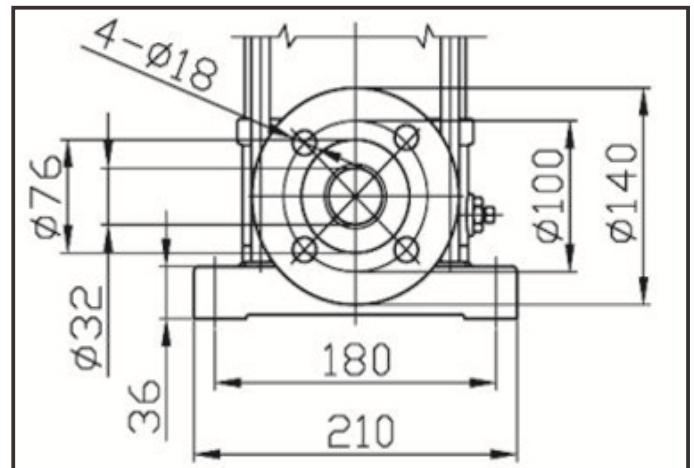
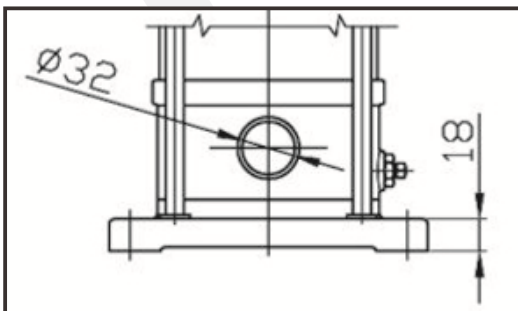
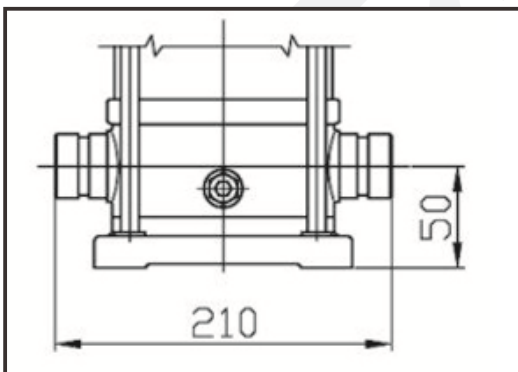
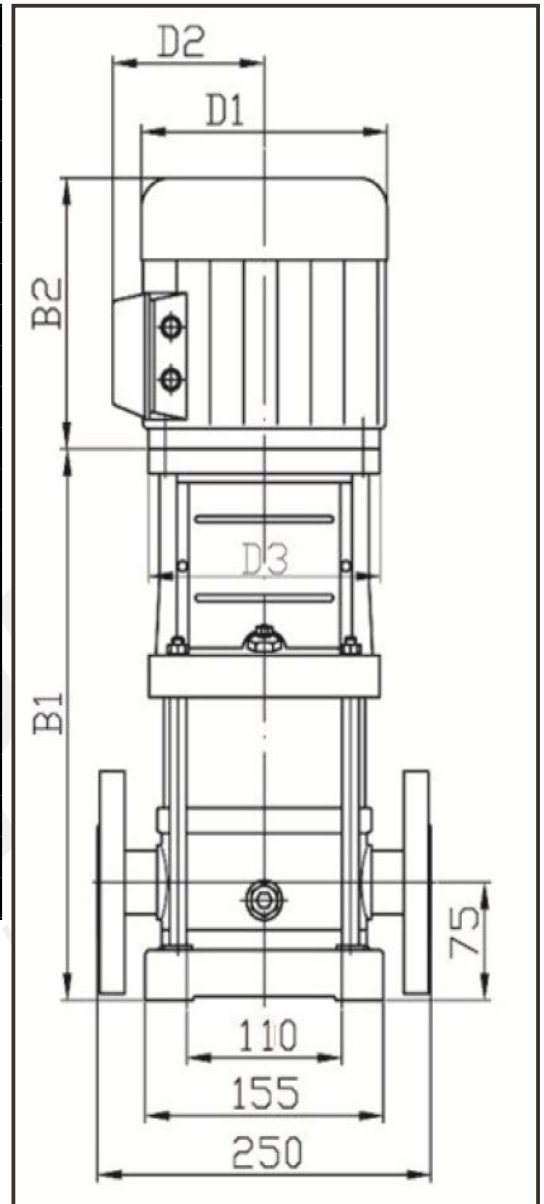

PERFORMANCE CURVES

DL8

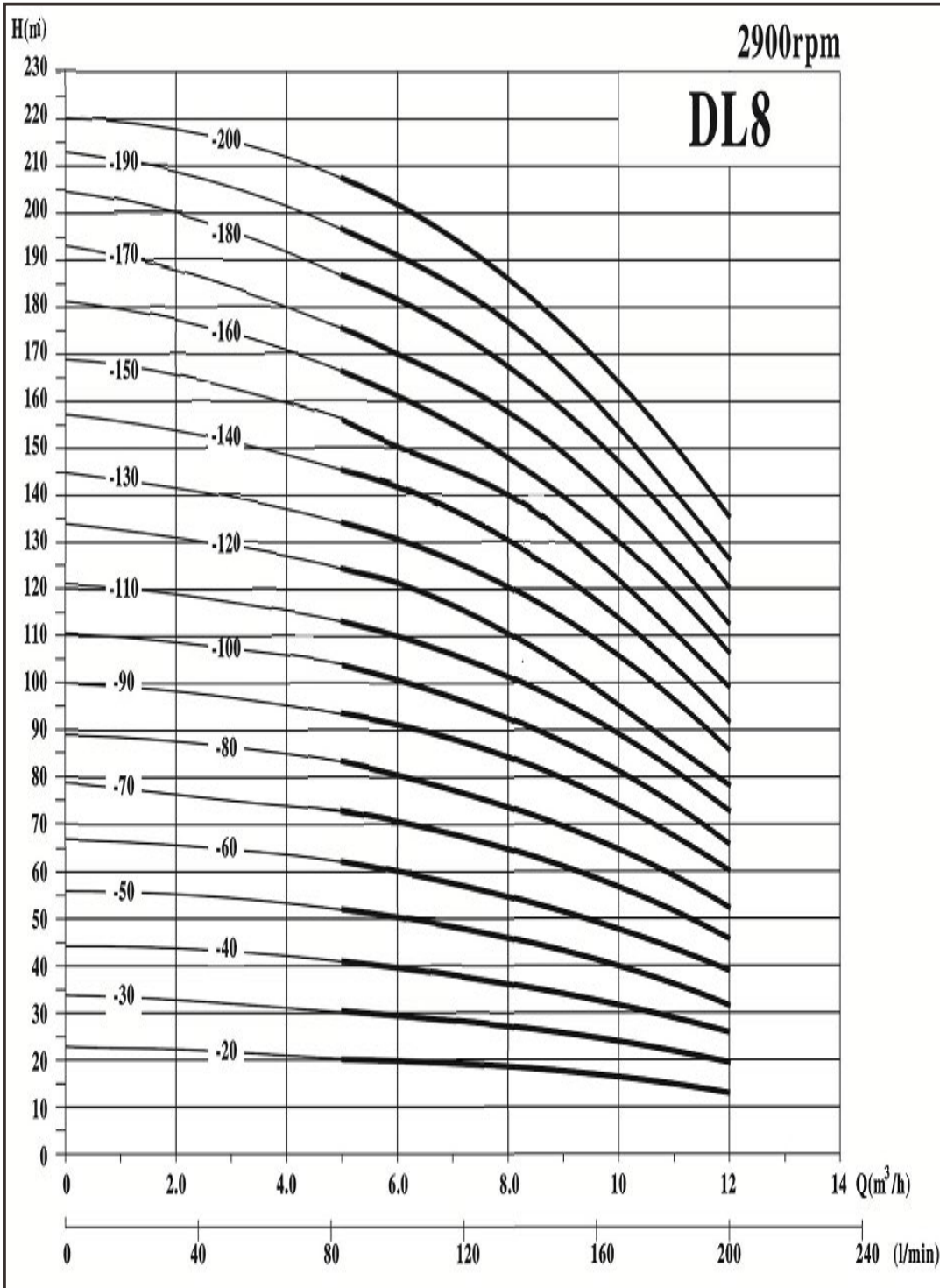

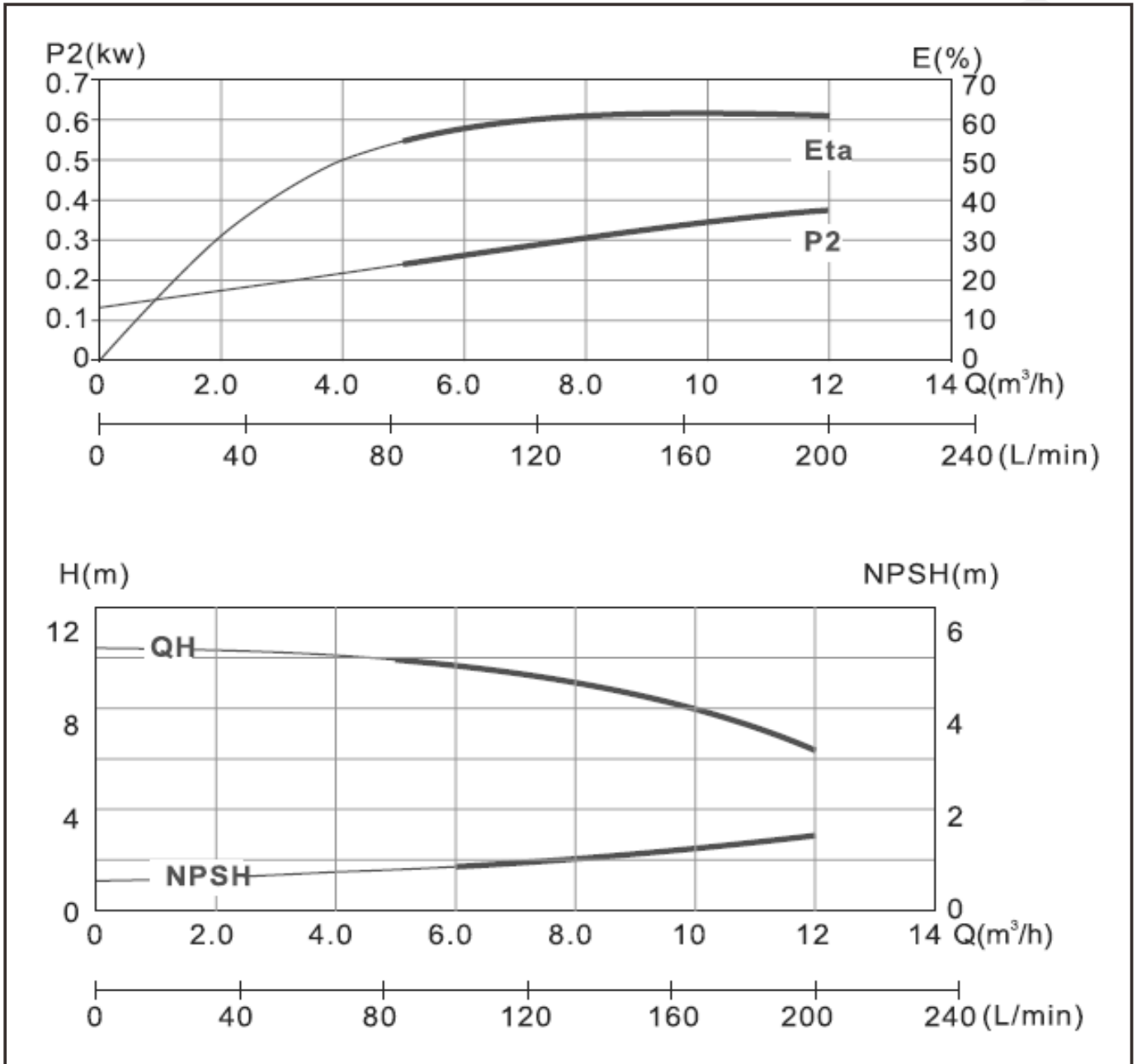

PERFORMANCE TABLE

DL8

MODEL	POWER		CAPACITY								
	kW	HP	m ³ /h	5.0	6.0	7.0	8.0	9.0	10	11	12
3 Phase 380V 50Hz			l/min	83	100	117	133	150	167	183	200
DL8-20	0.75	1.0	Head (m)	20	19.5	19	18	17	16	14	13
DL8-30	1.1	1.5		30	29.5	28.5	27	25	24	21	19
DL8-40	1.5	2.0		41	39.5	38	36	34	32	28	26
DL8-50	2.2	3.0		52	50	48	45	42	40	36	32
DL8-60	2.2	3.0		62	60	57	54	51	48	43	39
DL8-70	3.0	4.0		72	70	68	65	61	57	51	46
DL8-80	3.0	4.0		83	80	77	73	69	65	58	52
DL8-90	3.0	4.0		93	90.5	87	84	78	73	66	60
DL8-100	4.0	5.5		104	100	97	92	87	81	73	65
DL8-110	4.0	5.5		113	110	107	102	96	89	80	73
DL8-120	4.0	5.5		124	120	116	111	104	92	87	78
DL8-130	5.5	7.5		134	130.5	126	121	113	105	95	86
DL8-140	5.5	7.5		145	141	136	130	122	113	102	92
DL8-150	5.5	7.5		154.5	150	145.5	140	131	121.5	110	99
DL8-160	5.5	7.5		166	161	156	148	139	130	118	106
DL8-170	7.5	10		175	170	165	158	148	138	124	112
DL8-180	7.5	10		187	182	175	167	157	146	134	120
DL8-190	7.5	10		196	191	184	177	165	154	139	126
DL8-200	7.5	10		208	202	195	186	175	163	150	135

PUMP DIMENSIONS

MODEL	DIMENSIONS (mm)						WEIGHT
	B1	B2	B1+B2	D1	D2	D3	
DL8-20	366	267	633	159	113	120	35
DL8-30	397	267	664	159	113	120	38.5
DL8-40	431	281	712	177	122	140	46.5
DL8-50	461	281	742	177	122	140	50
DL8-60	491	281	772	177	122	140	50
DL8-70	531	328	859	197	128	160	59
DL8-80	562	328	890	197	128	160	59
DL8-90	592	328	920	197	128	160	59
DL8-100	622	307	929	216	152	160	69
DL8-110	652	307	959	216	152	160	69
DL8-120	682	307	989	216	152	160	69
DL8-130	738	382	1120	256	169	300	95
DL8-140	768	382	1150	256	169	300	95
DL8-150	798	382	1180	256	169	300	95
DL8-160	828	382	1210	256	169	300	95
DL8-170	858	382	1240	256	169	300	110
DL8-180	889	382	1271	256	169	300	110
DL8-190	919	382	1301	256	169	300	110
DL8-200	949	382	1331	256	169	300	110

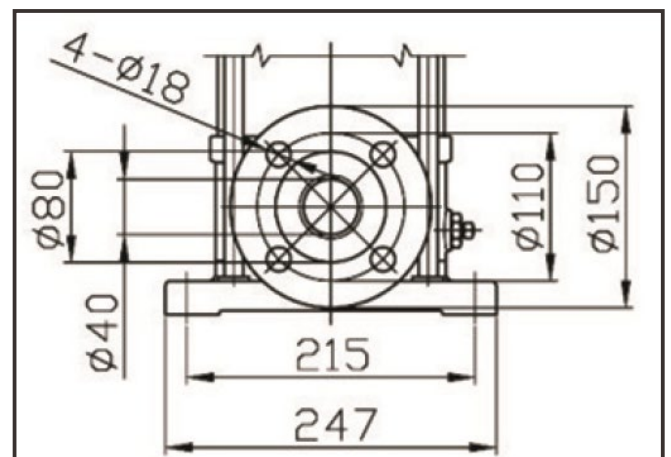
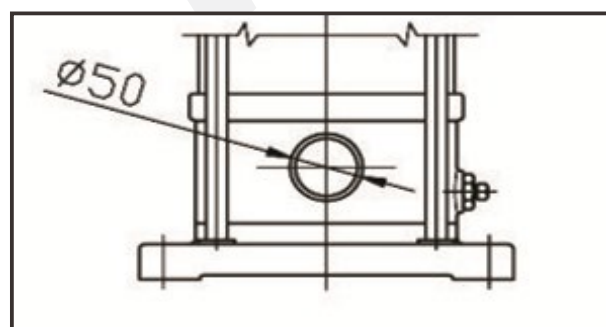
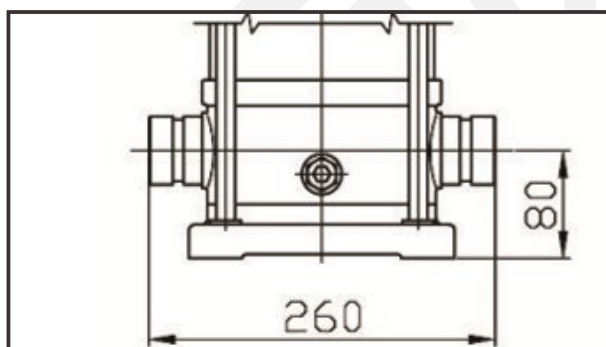
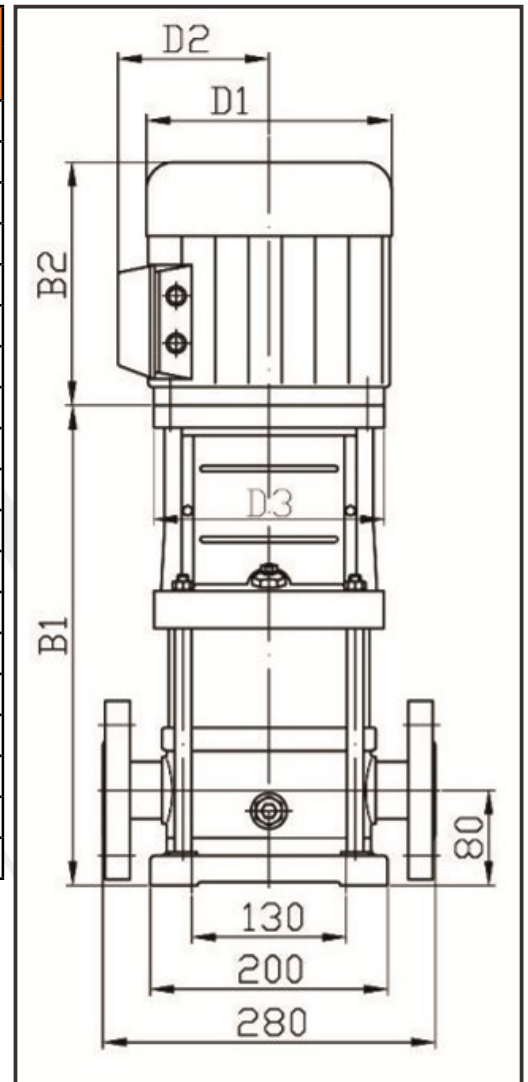

PERFORMANCE CURVES

DL12

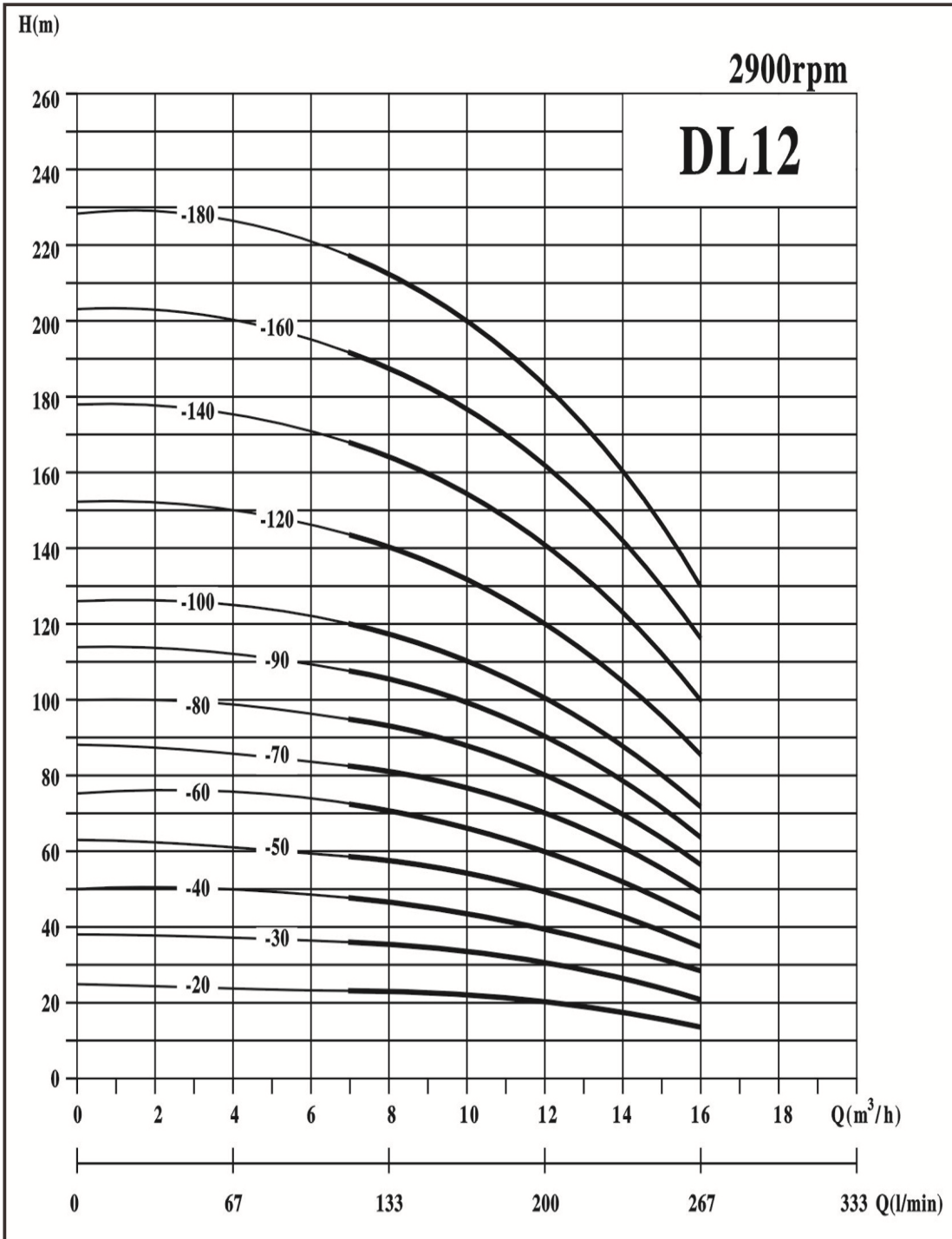

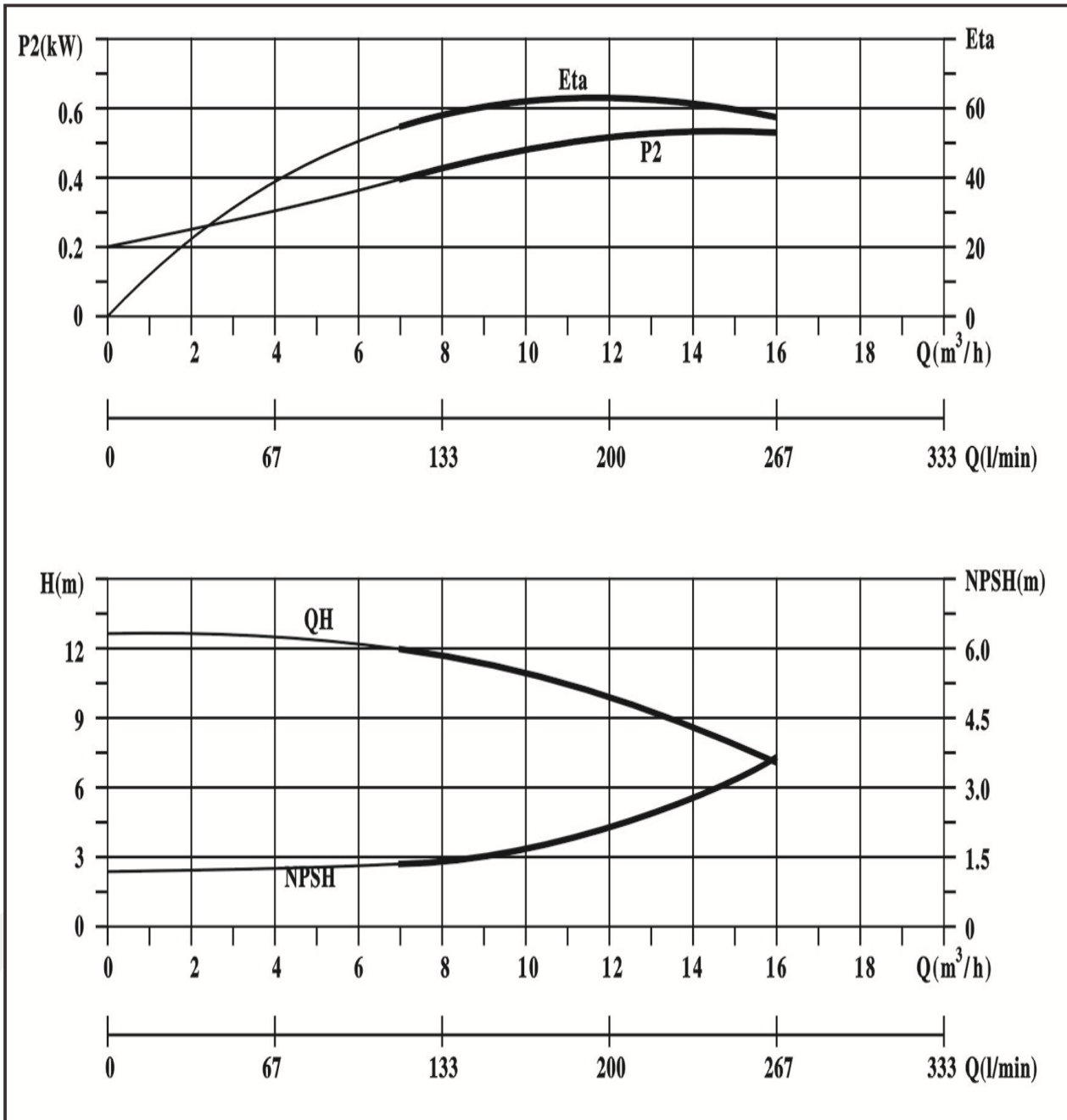

PERFORMANCE TABLE

DL12

MODEL	POWER		CAPACITY										
	kW	HP	m ³ /h	7	8	9	10	11	12	13	14	15	16
3 Phase 380V 50Hz				l/min	117	133	150	167	183	200	217	233	250
DL12-20	15	2.0	Head (m)	23.5	23	22.5	22	21	20	18.5	17	15.5	14
DL12-30	2.2	3.0		35.5	35	34	33	31.5	30	28	26	23.5	21
DL12-40	3.0	4.0		47	46	45	44	42	40	37	34	31	28
DL12-50	3.0	4.0		59.5	58	56.5	55	52.5	50	46.5	43	39	35
DL12-60	4.0	5.5		71.5	70	68	66	63	60	56	52	47	42
DL12-70	5.5	7.5		83.5	82	79.5	77	73.5	70	65.5	61	55	49
DL12-80	5.5	7.5		95.5	94	91	88	84	80	75	70	63	56
DL12-90	5.5	7.5		108	106	103	100	95.5	91	85	79	71.5	64
DL12-100	7.5	10		120	118	114.5	111	106	101	94.5	88	80	72
DL12-120	7.5	10		143.5	141	137	133	127	121	113.5	106	96	86
DL12-140	11	15		168	165	160	155	148	141	132.5	124	112	100
DL12-160	11	15		192.5	189	183.5	178	170	162	152	142	128	115
DL12-180	11	15		217	213	207	202	193	183	171	160	145	130

PUMP DIMENSIONS

MODEL	DIMENSIONS (mm)						WEIGHT
	B1	B2	B1+B2	D1	D2	D3	
DL12-20	366	281	647	177	122	140	42
DL12-30	397	281	678	177	122	140	46
DL12-40	431	328	759	197	128	160	54
DL12-50	461	328	789	197	128	160	54
DL12-60	491	307	798	216	152	160	61
DL12-70	531	382	913	256	169	300	81
DL12-80	562	382	944	256	169	300	81
DL12-90	592	382	974	256	169	300	81
DL12-100	622	382	1004	256	169	300	102
DL12-120	682	382	1064	256	169	300	102
DL12-140	768	420	1188	256	169	350	128
DL12-160	828	505	1394	330	240	350	128
DL12-180	889	505	1394	330	240	350	128

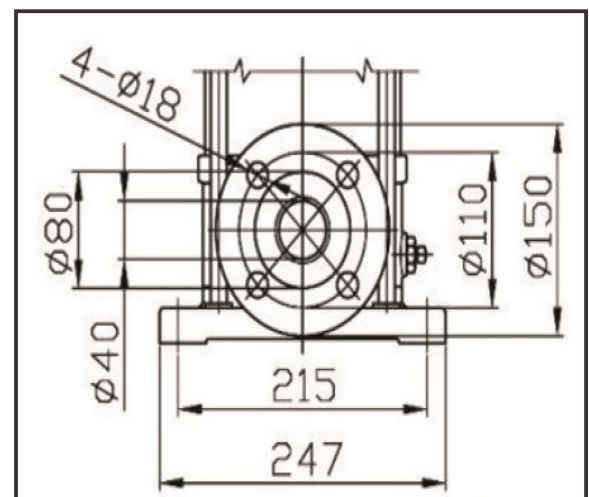
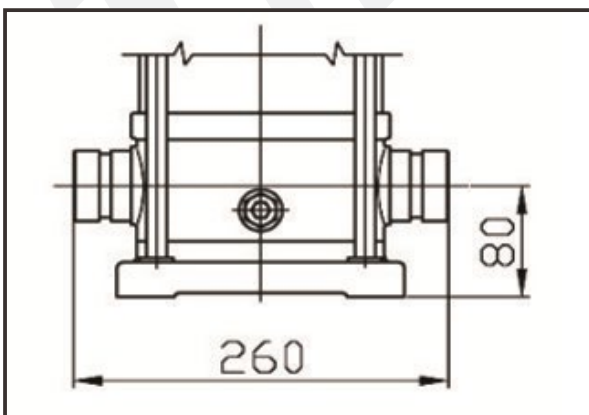
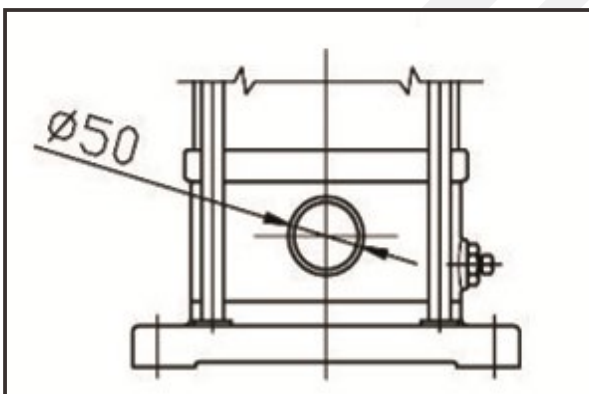
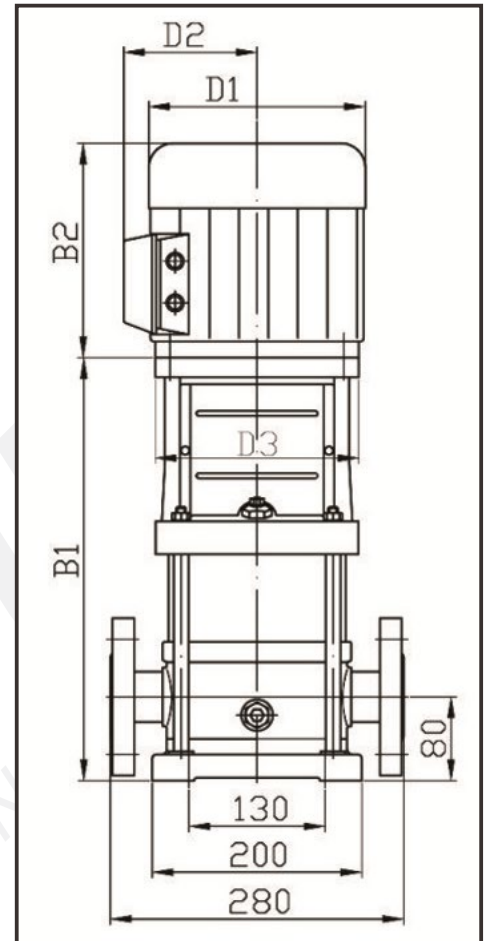

PERFORMANCE CURVES

DL16

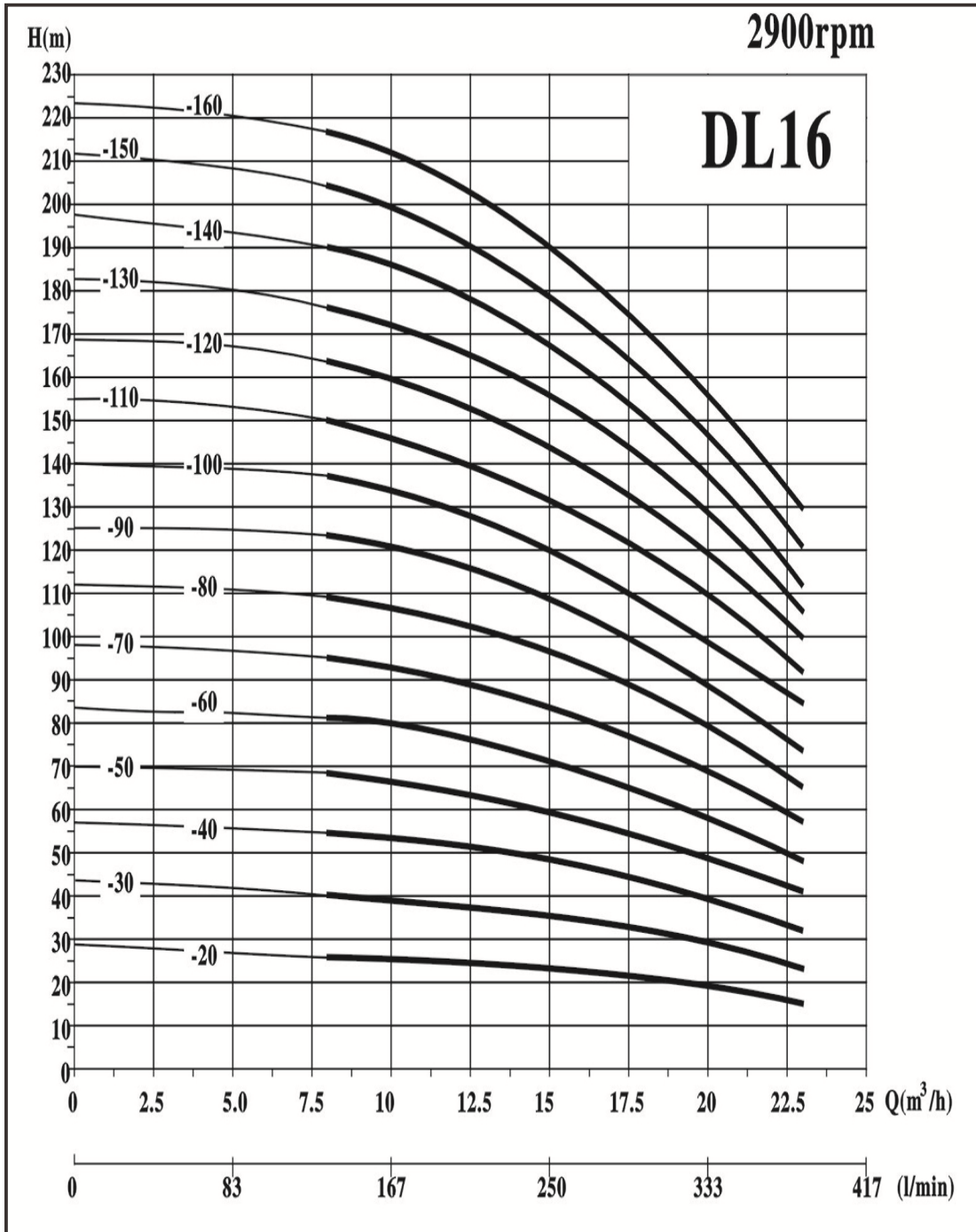

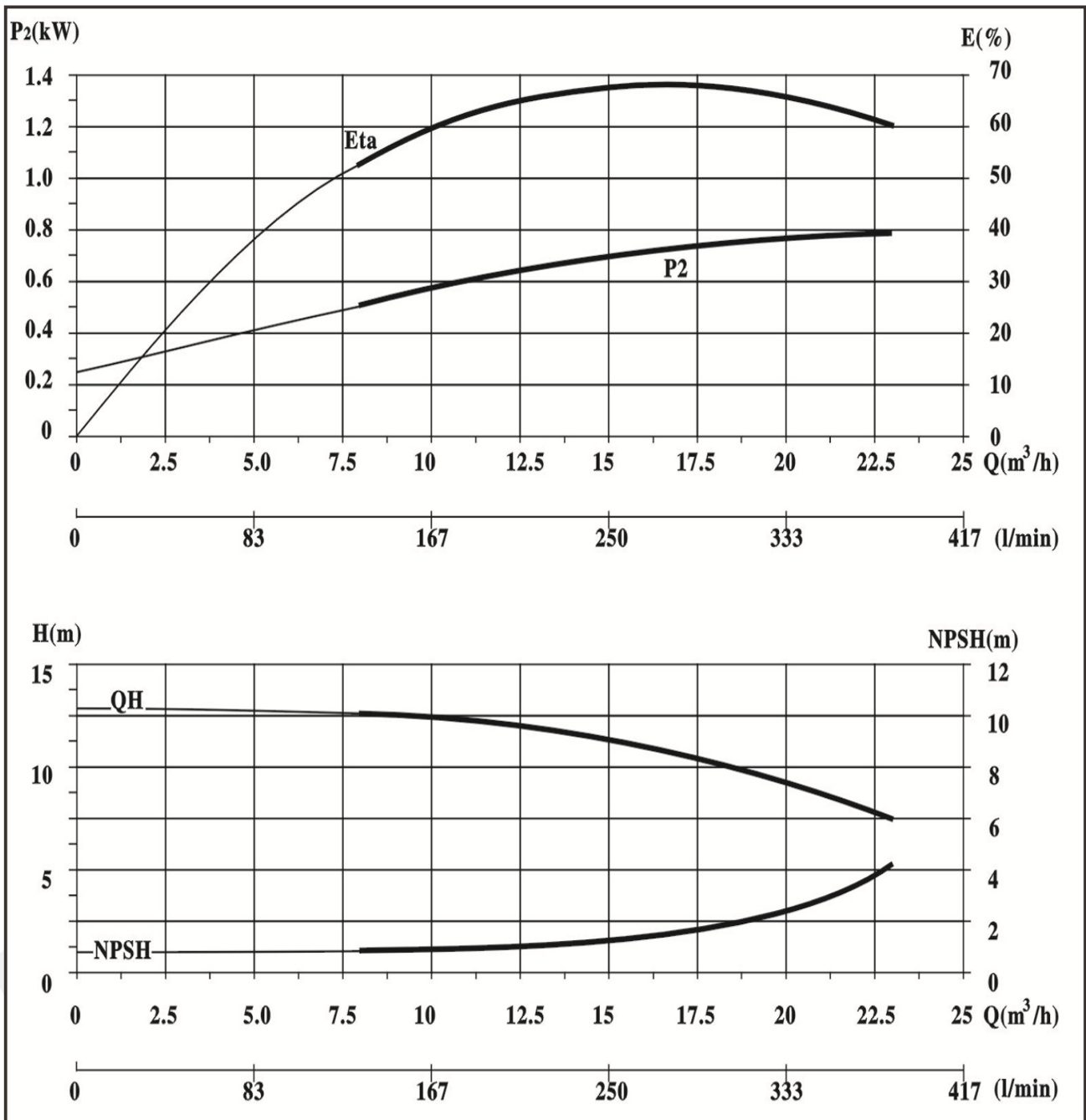

PERFORMANCE TABLE

DL16

MODEL	POWER		CAPACITY										
	kW	HP	m ³ /h	8	10	12	14	15	16	18	20	22	23
3 Phase 380V 50Hz					133	167	200	233	250	267	300	333	367
DL16-20	2.2	3.0	Head (m)	26	26	25	24	23	22	21.5	19	16.5	15
DL16-30	3.0	4.0		40	39	37.5	36	35	34.5	31.5	30	25.5	23
DL16-40	4.0	5.5		54	53	50	49	47	46.5	42	39	34.5	32
DL16-50	4.0	5.5		68	66	63	61	59	57.5	53	49	44	41
DL16-60	5.5	7.5		81	80	77	73	71	70	64	59	52	48
DL16-70	5.5	7.5		95	93	90	85	83	80.5	75	69	60	57
DL16-80	7.5	10		109	106	102	98	96	93	87	79	70	66
DL16-90	7.5	10		123	119	116	111	108	104	98	89	78	74
DL16-100	11	15		137	133	130	124	120	118	110	100	89	85
DL16-110	11	15		150	147	143	136	131	129	121	110	97	92
DL16-120	11	15		163	160	156	148	143	140	131	120	105	100
DL16-130	11	15		176	173	168	160	154	151	141	129	113	106
DL16-140	11	15		190	186	180	172	166	162	151	138	122	112
DL16-150	15	20		204	199	192	184	178	173	161	147	131	121
DL16-160	15	20		217	212	204	196	190	184	172	156	140	130

PUMP DIMENSIONS

MODEL	DIMENSIONS (mm)						WEIGHT
	B1	B2	B1+B2	D1	D2	D3	
DL16-20	407	281	688	177	122	140	42
DL16-30	463	328	791	197	128	160	56
DL16-40	508	307	815	216	152	160	58
DL16-50	553	307	860	216	152	160	60
DL16-60	623	382	1005	256	169	300	89
DL16-70	668	382	1050	256	169	300	91
DL16-80	714	382	1096	256	169	300	102
DL16-90	759	382	1141	256	169	300	104
DL16-100	829	420	1249	256	169	350	136
DL16-110	874	505	1379	330	240	350	138
DL16-120	919	505	1424	330	240	350	140
DL16-130	965	505	1470	330	240	350	142
DL16-140	1010	505	1515	330	240	350	144
DL16-150	1055	505	1560	330	240	350	188
DL16-160	1100	505	1605	330	240	350	190

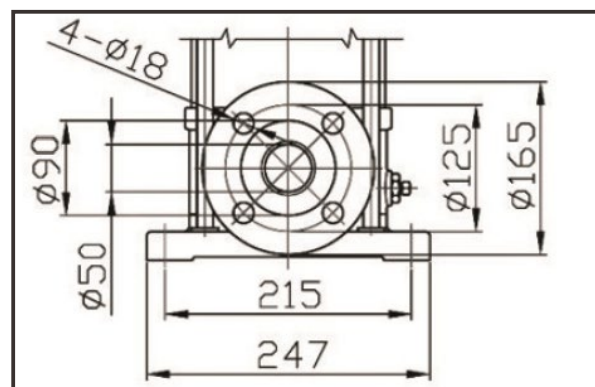
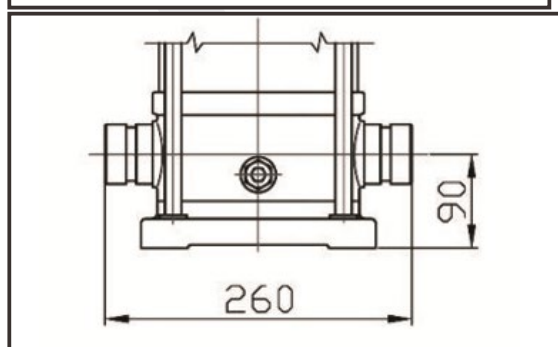
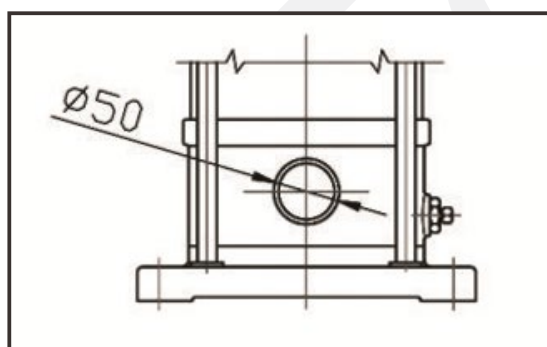
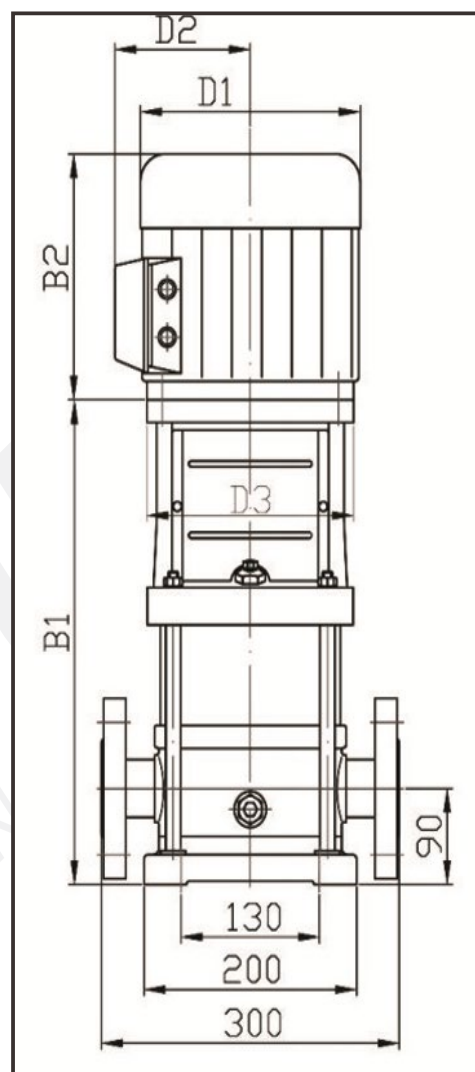

PERFORMANCE CURVES

DL20

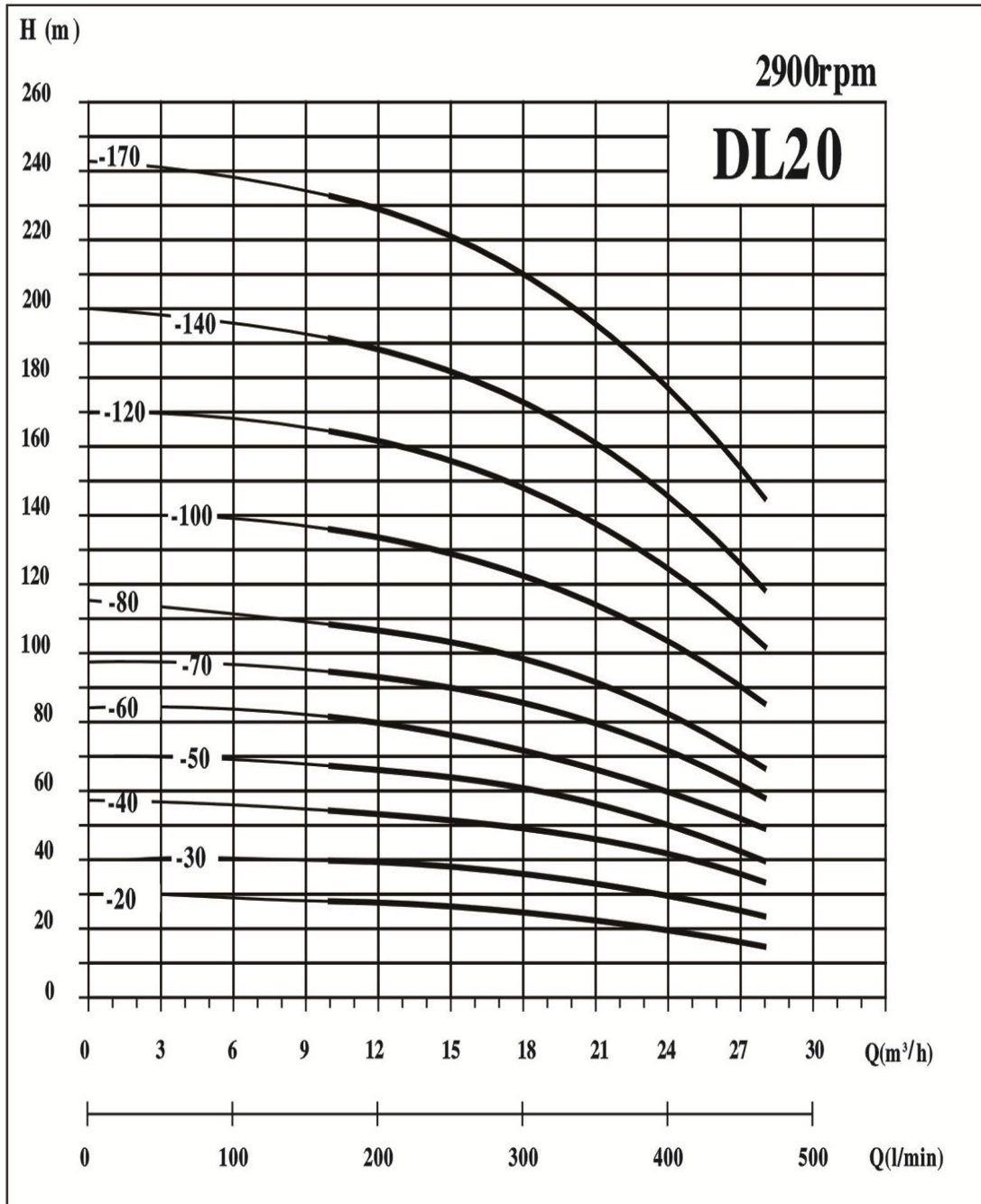

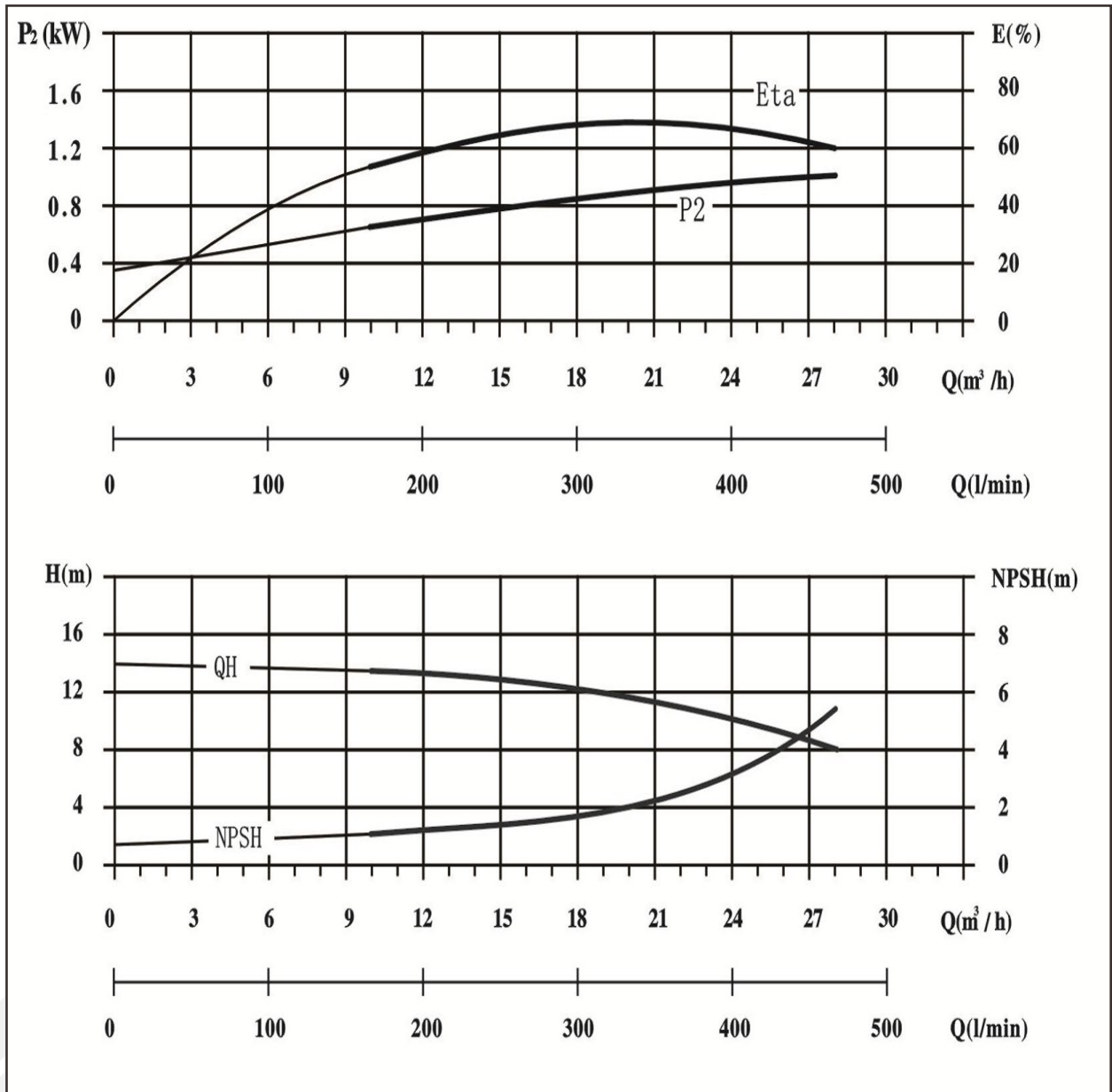

PERFORMANCE TABLE

DL20

MODEL	POWER		CAPACITY										
	kW	HP	m ³ /h	10	12	14	16	18	20	22	24	26	28
3 Phase 380V 50Hz			l/min	167	200	233	267	300	333	367	400	433	467
DL20-20	2.2	3.0	Head (m)	27	26.5	26	25	24	23	22	20	18	15
DL20-30	4.0	5.5		40	39.5	39	38	37	35	33	30	27	24
DL20-40	5.5	7.5		54	53	52	51	49	47	44	41	37	33
DL20-50	5.5	7.5		67	66	64	62	60	58	55	50	45	40
DL20-60	7.5	10		81	79	77	75	73	70	66	61	55	49
DL20-70	7.5	10		95	93	91	89	86	82	77	71	65	58
DL20-80	11	15		109	107	105	102	99	94	89	82	75	67
DL20-100	11	15		136	134	131	128	124	118	111	103	95	85
DL20-120	15	20		164	162	158	154	149	142	133	124	111	102
DL20-140	15	20		192	189	185	180	174	166	156	145	133	119
DL20-170	18.5	25		234	230	225	219	212	202	190	177	162	145

PUMP DIMENSIONS

MODEL	DIMENSIONS (mm)						WEIGHT
	B1	B2	B1+B2	D1	D2	D3	
DL20-10	358	267	625	159	113	140	35
DL20-20	407	281	688	177	122	140	42
DL20-30	463	307	770	216	152	160	62
DL20-40	533	382	915	256	169	160	74
DL20-50	578	382	960	256	169	160	76
DL20-60	623	382	1005	256	169	300	106
DL20-70	668	382	1050	256	169	300	108
DL20-80	739	420	1159	256	169	350	117
DL20-100	829	505	1334	330	240	350	119
DL20-120	919	505	1424	330	240	350	182
DL20-140	1010	505	1515	330	240	350	184
DL20-170	1146	560	1706	330	240	350	205

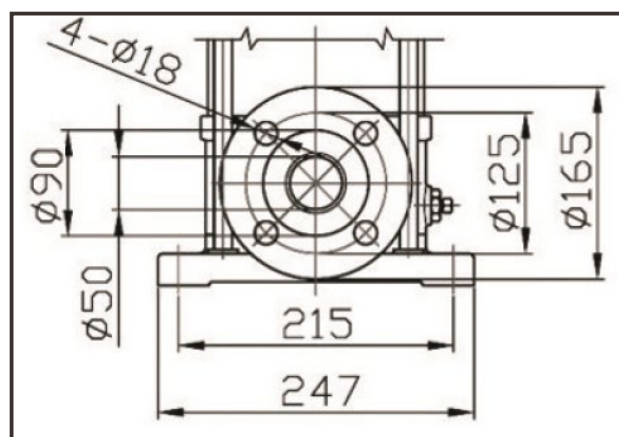
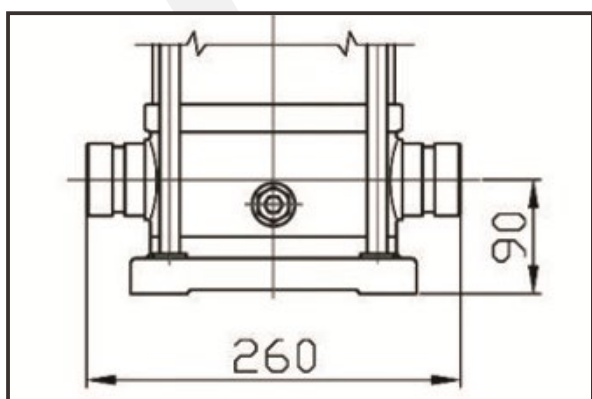
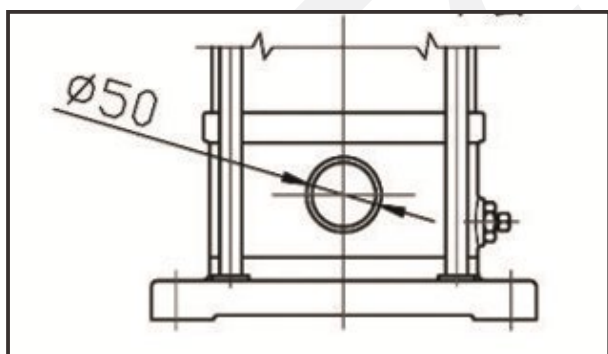
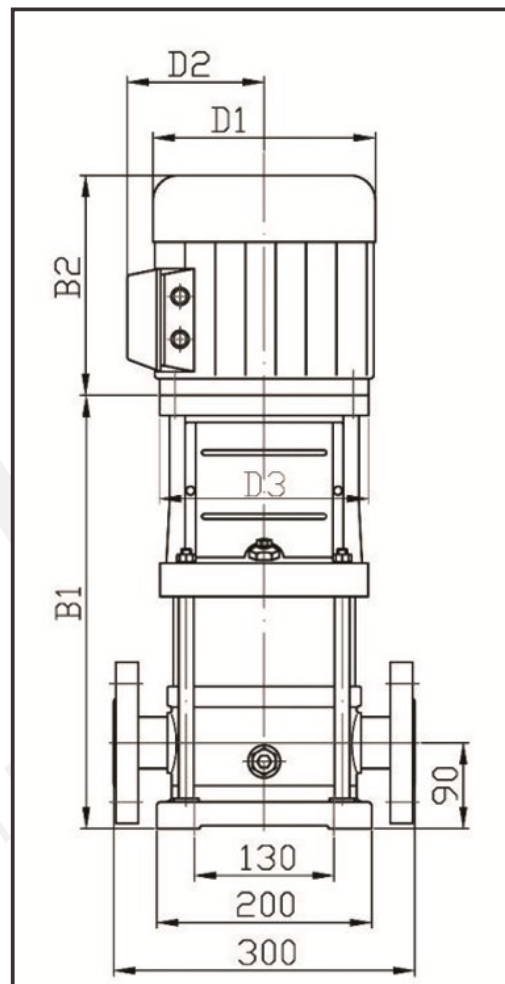

PERFORMANCE CURVES

DL32

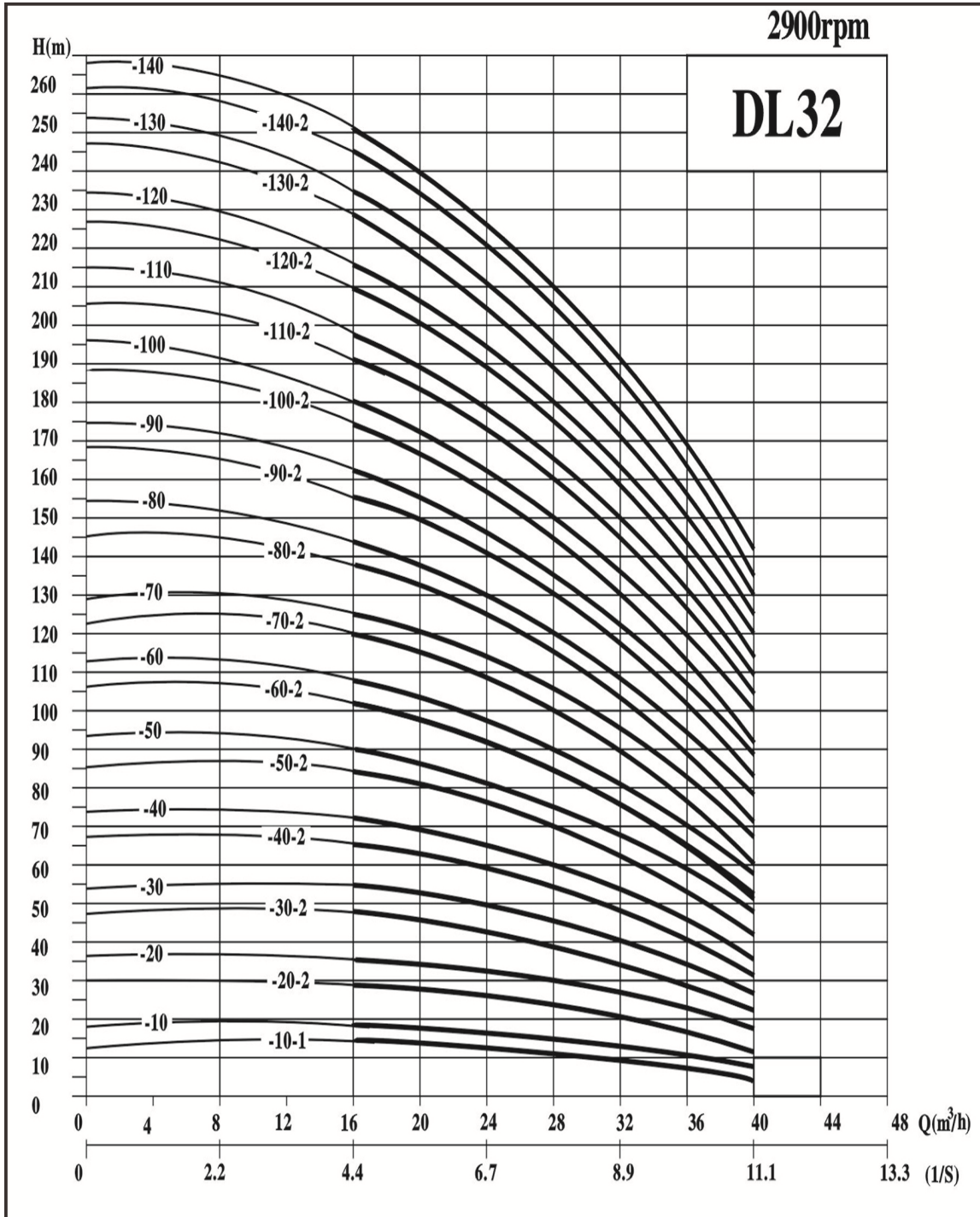

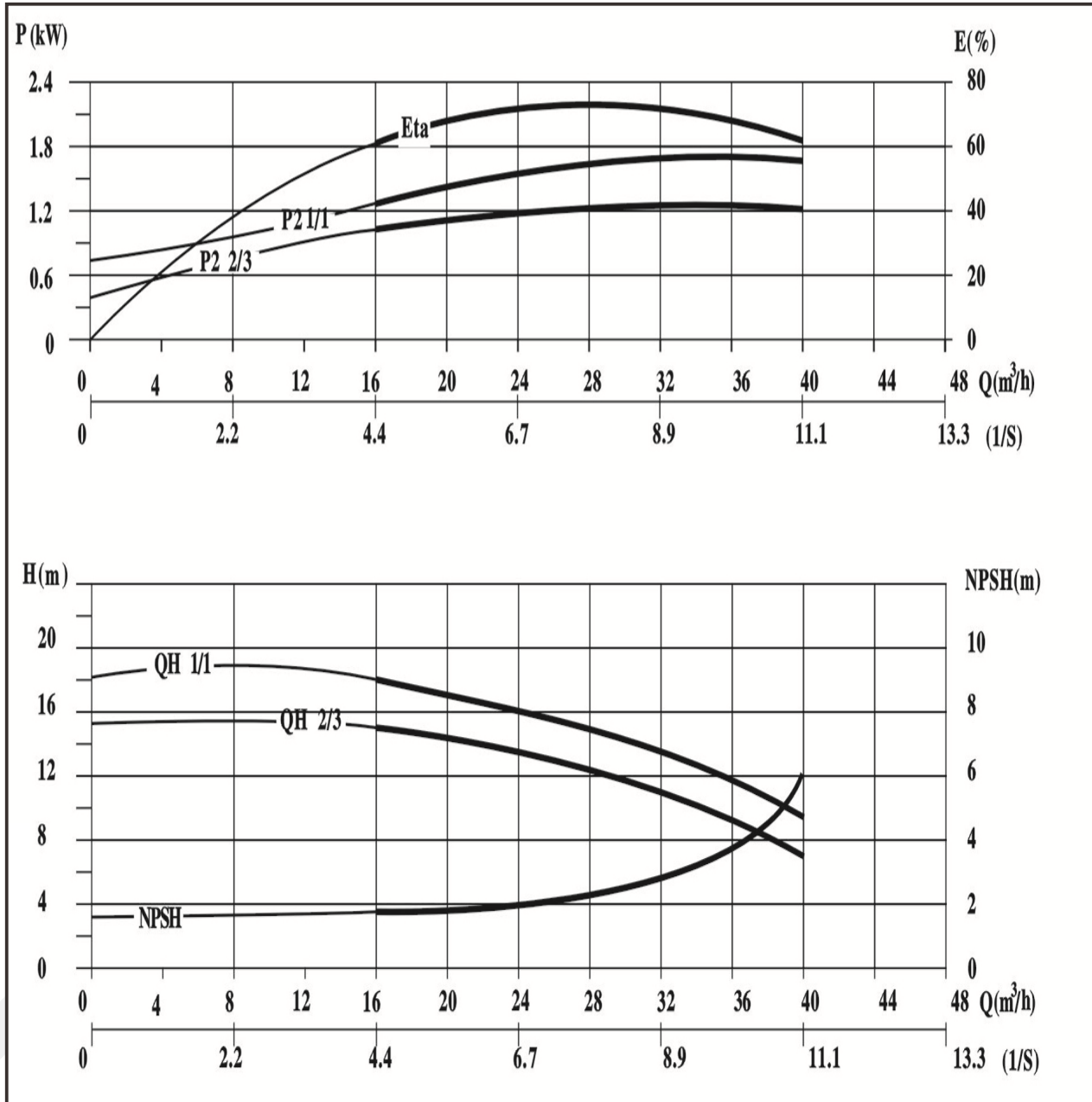

PERFORMANCE TABLE

DL32

MODEL	POWER		CAPACITY							
	kW	HP	m ³ /h	16	20	24	28	32	36	40
3 Phase 380V 50Hz				I/S	4.4	5.6	6.7	7.8	8.9	10
DL32-10-1	1.5	2.0	Head (m)	15	14	13	11.5	9.5	7	4
DL32-10	2.2	3.0		18	17	15	14	13	11	8
DL32-20-2	3.0	4.0		29	28	26	23	20	16	12
DL32-20	4.0	5.5		36	34	32	30	27	23	18
DL32-30-2	5.5	7.5		47	44	41	38	33	28	22
DL32-30	5.5	7.5		54	51	48	45	40	36	27
DL32-40-2	7.5	10		66	63	58	53	46	40	32
DL32-40	7.5	10		72	68	64	60	54	48	36
DL32-50-2	11	15		84	80	75	70	60	52	42
DL32-50	11	15		90	85	80	75	68	60	48
DL32-60-2	11	15		102	97	91	85	75	66	53
DL32-60	11	15		108	102	96	90	82	72	58
DL32-70-2	15	20		120	114	107	100	89	78	61
DL32-70	15	20		126	119	112	105	96	84	68
DL32-80-2	15	20		138	131	123	115	103	90	72
DL32-80	15	20		144	136	128	120	110	96	78
DL32-90-2	18.5	25		155	148	139	130	118	102	83
DL32-90	18.5	25		162	155	146	136	124	108	89
DL32-100-2	18.5	25		174	165	155	145	132	114	92
DL32-100	18.5	25		180	170	160	150	138	120	100
DL32-110-2	22	30		192	182	171	160	146	126	105
DL32-110	22	30		198	187	176	165	153	135	110
DL32-120-2	22	30		210	199	187	175	160	138	115
DL32-120	22	30		216	204	192	180	168	147	120
DL32-130-2	30	40		228	216	203	190	174	153	125
DL32-140-2	30	40		246	233	219	205	190	162	135
DL32-140	30	40		252	238	224	210	196	170	142

PUMP DIMENSIONS

MODEL	DIMENSIONS (mm)						WEIGHT
	B1	B2	B1+B2	D1	D2	D3	
DL32-10-1	505	281	786	177	122	140	67.5
DL32-10	505	281	786	177	122	140	71
DL32-20-2	575	328	903	197	128	160	85
DL32-2	575	307	882	216	152	160	87
DL32-30-2	645	382	1027	256	169	300	93
DL32-30	645	382	1027	256	169	300	95
DL32-40-2	715	382	1097	256	169	300	102
DL32-40	715	382	1097	256	169	300	105
DL32-50-2	895	420	1315	256	169	350	172
DL32-50	895	420	1315	256	169	350	175
DL32-60-2	965	505	1470	330	260	350	176
DL32-60	965	505	1470	330	260	350	177
DL32-70-2	1035	505	1540	330	260	350	188
DL32-70	1035	505	1540	330	260	350	190
DL32-80-2	1105	505	1610	330	260	350	192
DL32-80	1105	505	1610	330	260	350	194
DL32-90-2	1175	560	1735	330	260	350	218
DL32-90	1175	560	1735	330	260	350	220
DL32-100-2	1245	5960	1805	330	260	350	222
DL32-100	1245	560	1805	330	260	350	224
DL32-110-2	1315	590	1905	360	275	350	259
DL32-110	1315	590	1905	360	275	350	261
DL32-120-2	1385	590	1975	360	275	350	263
DL32-120	1385	590	1975	360	275	350	265
DL32-130-2	1455	660	2115	400	305	400	327
DL32-130	1455	660	2115	400	305	400	329
DL32-140-2	1525	660	2185	400	305	400	331
DL32-140	1525	660	2185	400	305	400	333

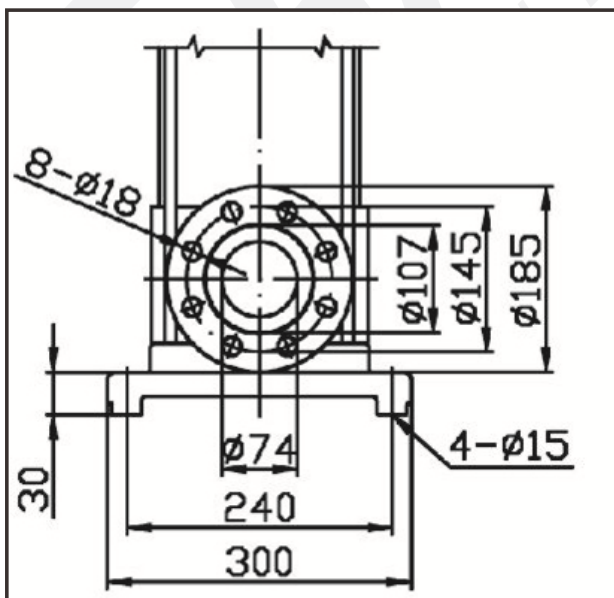
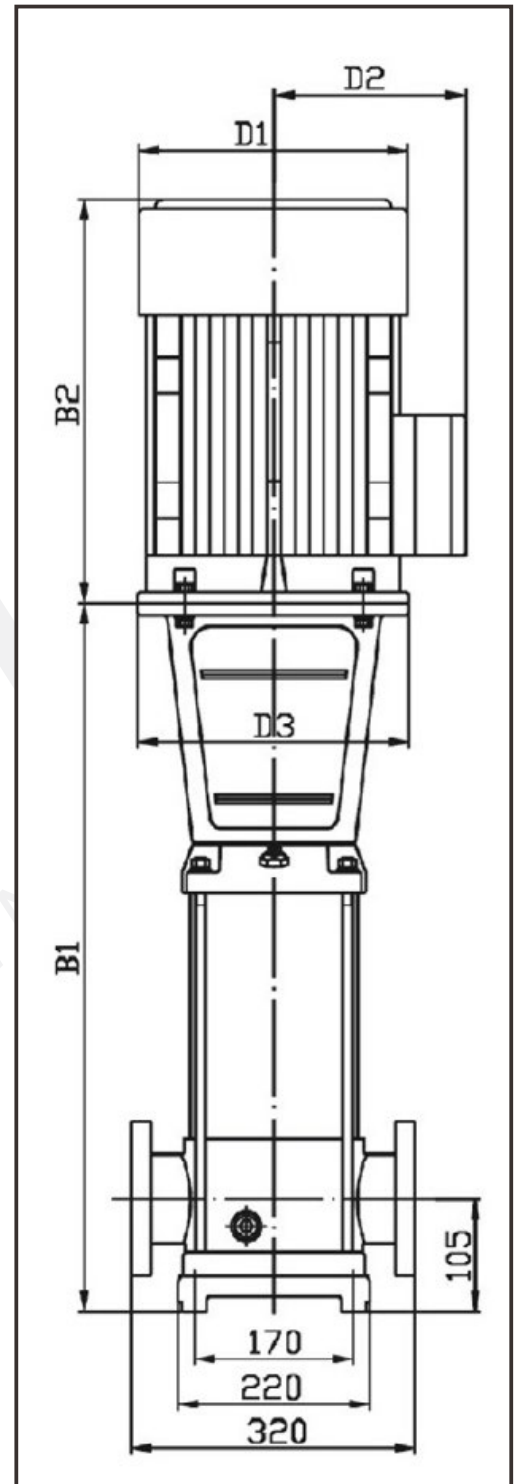

PERFORMANCE CURVES

DL45

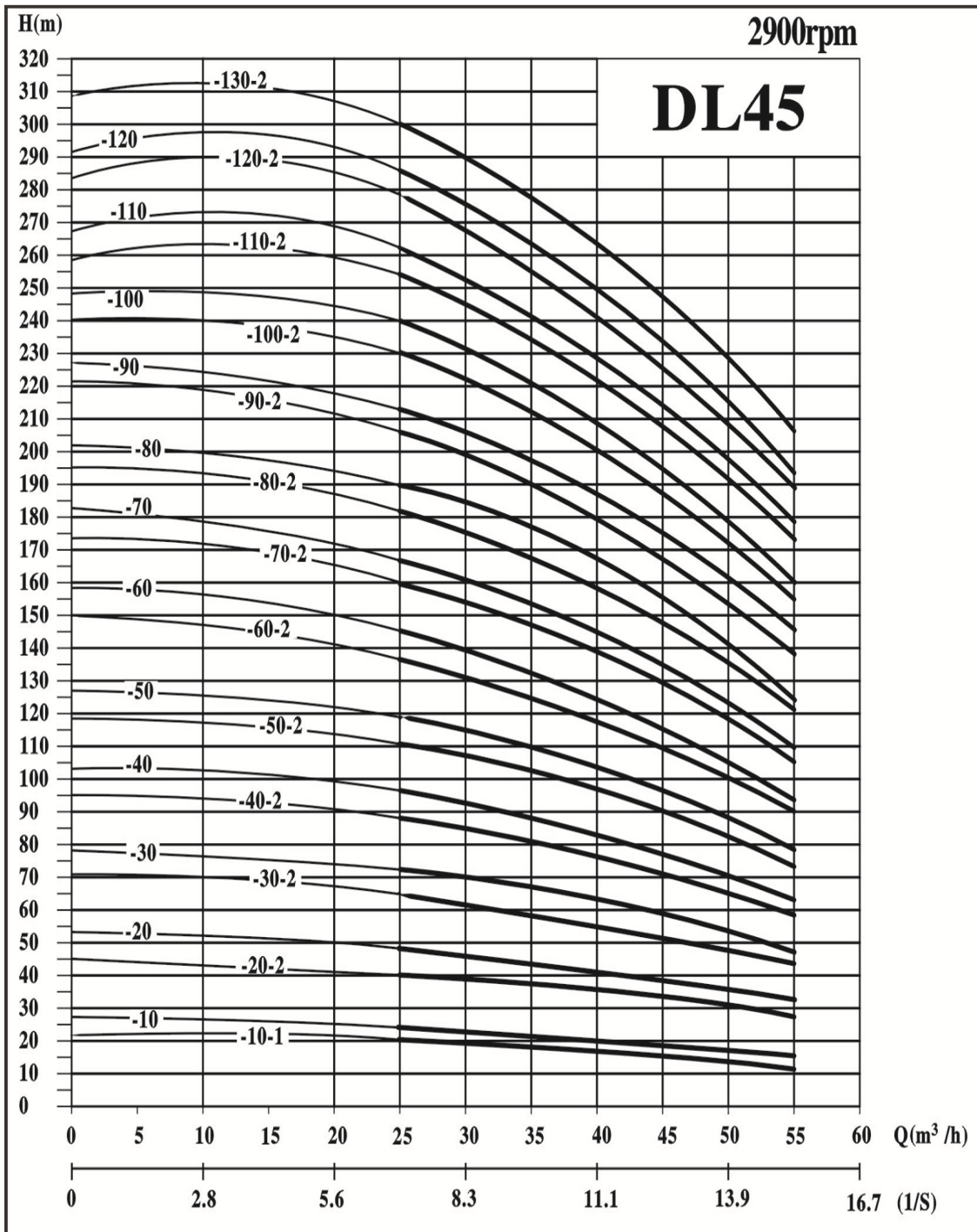

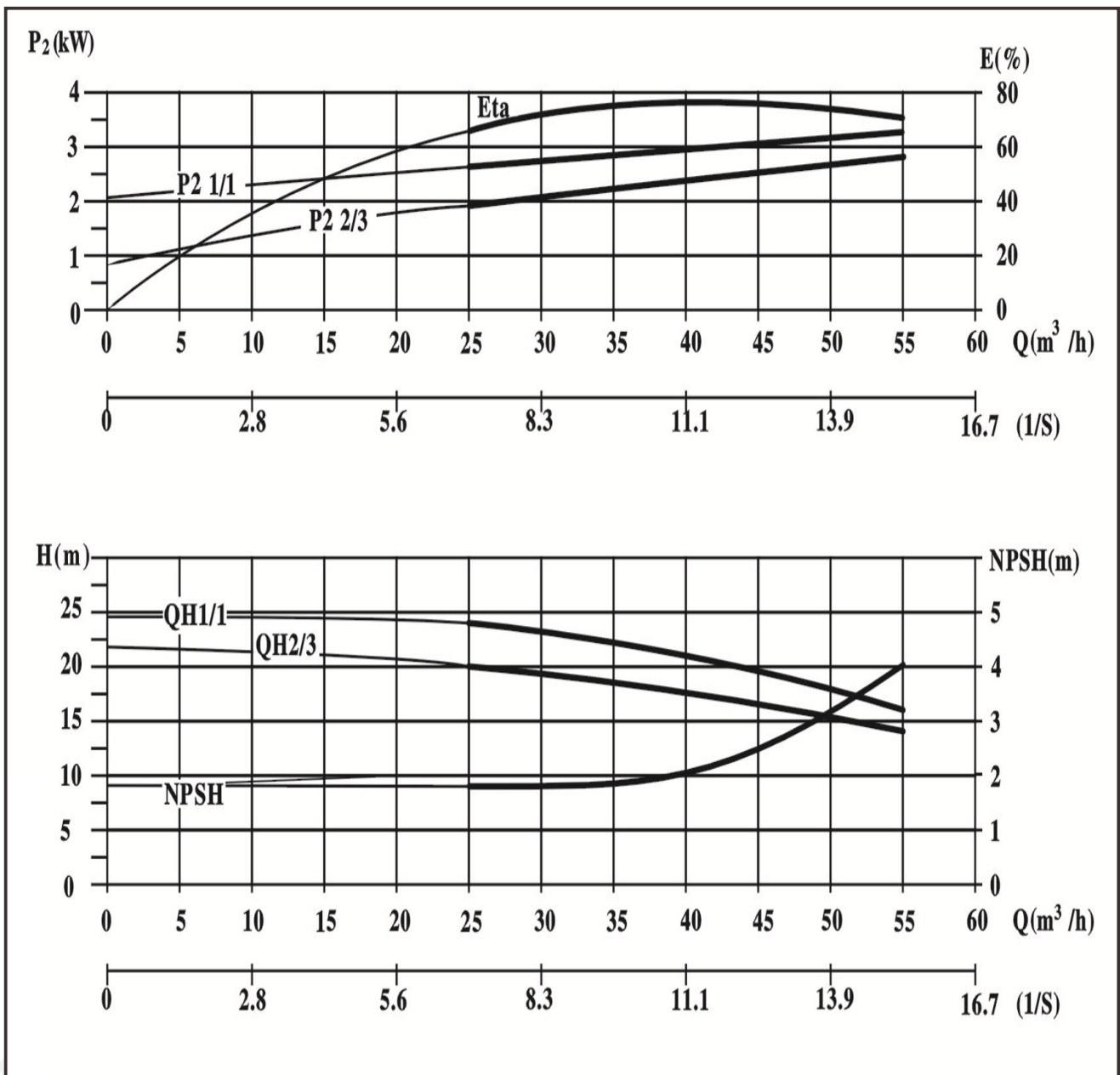

PERFORMANCE TABLE

DL45

MODEL	POWER		CAPACITY							
	kW	HP	m ³ /h	25	30	35	40	45	50	55
			l/s	6.9	8.3	9.7	11.1	12.5	13.9	15.3
DL45-10-1	3.0	4.0	Head (m)	20	19.5	18	17	16.5	16	14
DL45-10	4.0	5.5		24	23	22	21	19	17.5	16
DL45-20-2	5.5	7.5		40	38.5	36	34	33	31.5	27
DL45-20	7.5	10		48	46	44	42	39	34	31
DL45-30-2	11	15		64	61.5	58	55	52.5	49	43
DL45-30	11	15		71	69	66	63	58	53	47
DL45-40-2	15	20		88	84.5	80	76	71	65	58
DL45-40	15	20		95	92	88	84	77	71	63
DL45-50-2	18.5	25		111	107.5	102	96.5	90	84	74
DL45-50	18.5	25		119	115	110	105	97	88	78
DL45-60-2	22	30		134	130	124	118	110	102	90
DL45-60	22	30		143	138	132	125	116	106	93
DL45-70-2	30	40		159	153	146	139	130	119	106
DL45-70	30	40		166	161	154	146	135	124	109
DL45-80-2	30	40		183	176	168	159	148	137.5	122
DL45-80	30	40		190	184	176	167	154	141	124
DL45-90-2	30	40		208	199	192	180	167	154.5	138
DL45-90	37	50		216	206	197.5	189	171	158	145
DL45-100-2	37	50		231	222	212	201	186	172	154
DL45-100	37	50		240	231	221	210	189	176	160
DL45-110-2	45	60		256	244.5	234	224	205	189.5	172
DL45-110	45	60		265	263	243	231	209	192	176
DL45-120-2	45	60		280	268.5	256	244	223	207	187
DL45-120	45	60		288	276	264	252	228	210	192
DL45-130-2	45	60		305	291.5	279	256	242	224	203

PUMP DIMENSIONS

MODEL	DIMENSIONS (mm)						WEIGHT
	B1	B2	B1+B2	D1	D2	D3	
DL45-10-1	566	328	894	177	128	160	82
DL45-10	566	307	873	216	152	160	92
DL45-20-2	646	382	1028	256	169	300	103
DL45-2	646	382	1028	256	169	300	107
DL45-30-2	836	505	1341	330	260	350	175
DL45-30	836	505	1341	330	260	350	177
DL45-40-2	916	505	1421	330	260	350	187
DL45-40	916	505	1421	330	260	350	189
DL45-50-2	996	560	1556	330	260	350	208
DL45-50	996	560	1556	330	260	350	210
DL45-60-2	1076	590	1666	360	275	350	251
DL45-60	1076	590	1666	360	275	350	253
DL45-70-2	1156	660	1816	400	3605	400	315
DL45-70	1156	660	1816	400	305	400	317
DL45-80-2	1236	660	1896	400	305	400	319
DL45-80	1236	660	1896	400	305	400	321
DL45-90-2	1296	660	1956	400	305	400	323
DL45-90	1296	660	1956	400	305	400	351
DL45-100-2	1376	660	2036	400	305	400	355
DL45-100	1376	660	2036	400	305	400	357
DL45-110-2	1456	710	2166	450	305	450	424
DL45-110	1456	710	2166	450	305	450	426
DL45-120-2	1536	710	2246	450	305	450	428
DL45-120	1536	710	2246	450	305	450	430
DL45-130-2	1616	710	2326	450	3605	450	432

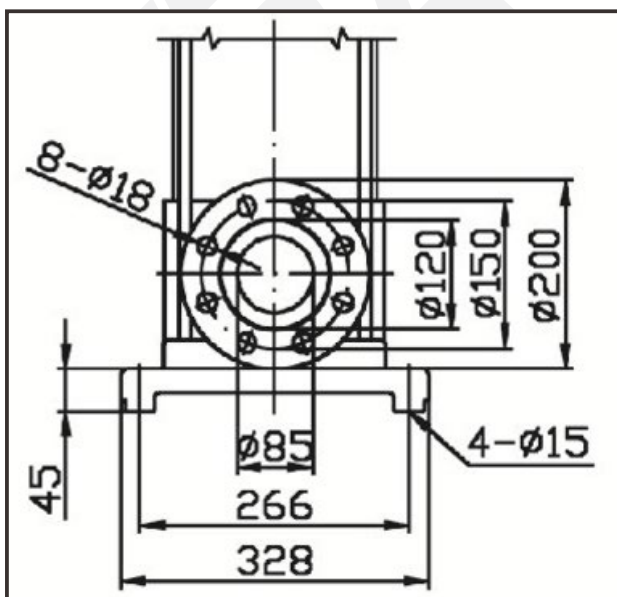
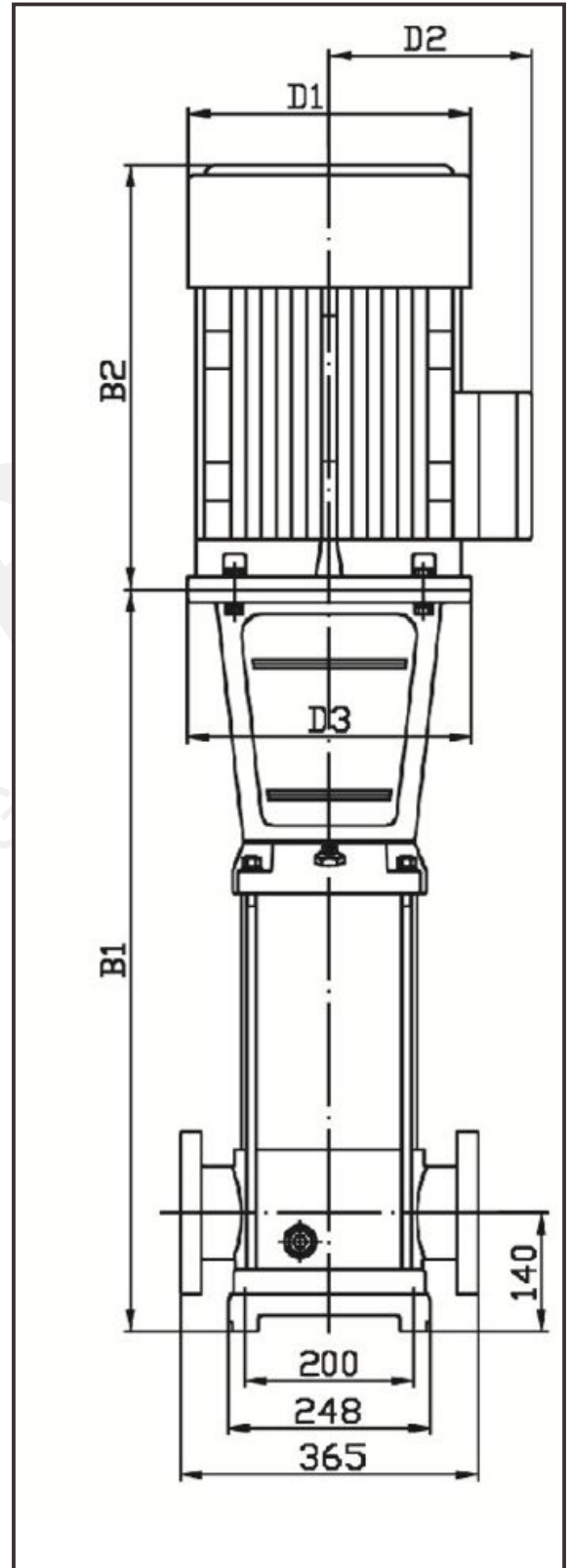

PERFORMANCE CURVES

DL64

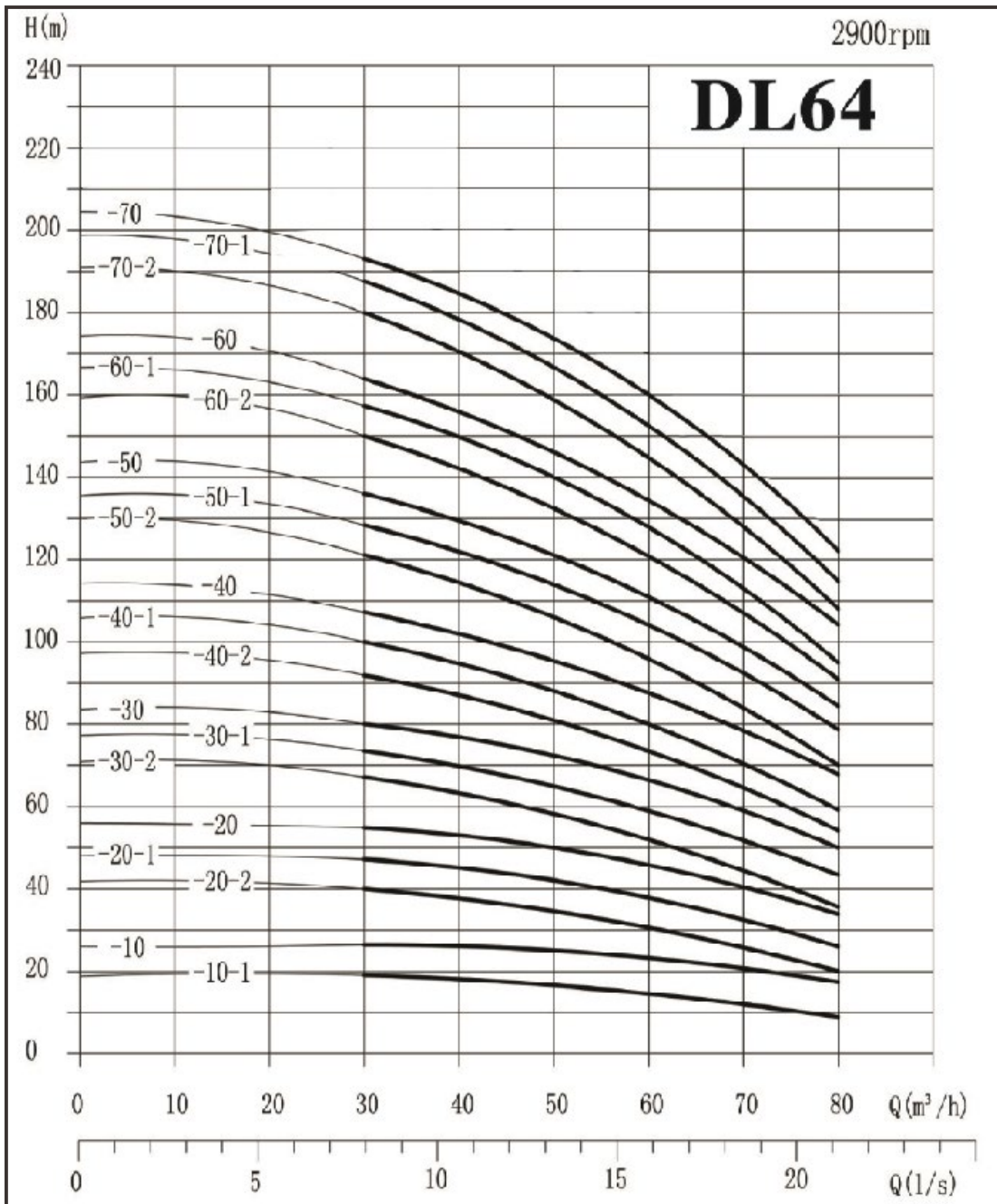

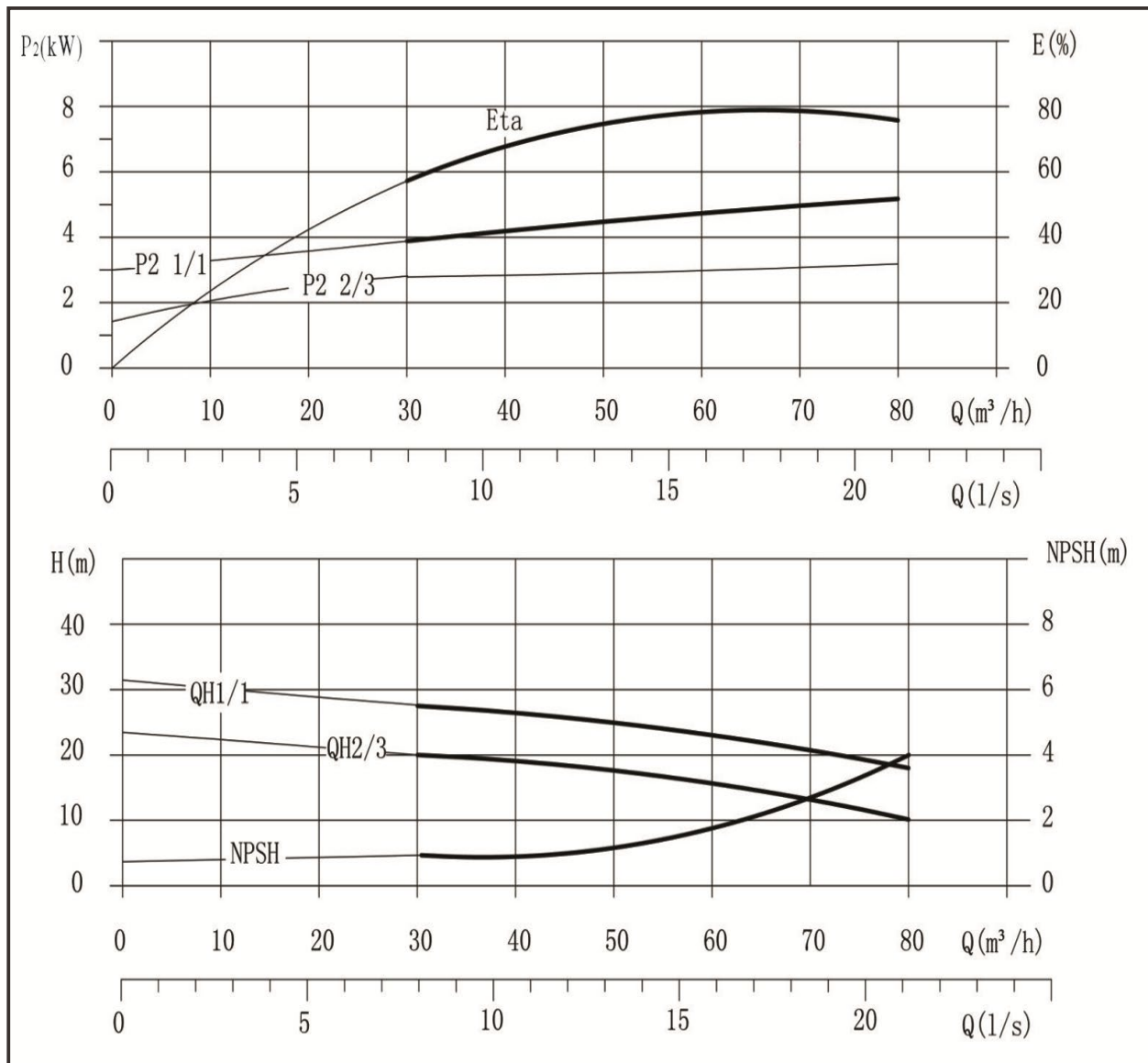

PERFORMANCE TABLE

DL64

MODEL	POWER		CAPACITY						
	kW	HP	m ³ /h	30	40	50	60	70	80
3 Phase 380V 50Hz				I/S	8.3	11.1	13.9	16.7	19.4
DL64-10-1	4.0	5.5	Head (m)	19	18	16	14	12	9
DL64-10	5.5	7.5		27.5	26	24.5	23	20	17
DL64-20-2	7.5	10		40	38	34	30	28	19
DL64-20-1	11	15		47	45	41.5	38	32	26
DL64-20	11	15		55	52	49	46	39	34
DL64-30-2	15	20		67	64	57	53	45	35
DL64-30-1	15	20		73	69	65	58	52	43
DL64-30	18.5	25		80	76	72	65	60	50
DL64-40-2	18.5	25		92	87	81	72	64	54
DL64-40-1	22	30		100	94	88	80	72	59
DL64-40	22	30		107	101	95	86	80	68
DL64-50-2	30	40		121	114	105	97	85	70
DL64-50-1	30	40		128	121	112	104	93	78
DL64-50	30	40		136	129	119	112	100	84
DL64-60-2	30	40		150	143	132	122	107	89
DL64-60-1	37	50		157	149	140	129	114	95
DL64-60	37	50		164	156	145	132	121	104
DL64-70-2	37	50		180	172	162	145	130	108
DL64-70-1	37	50		187	180	165	153	135	115
DL64-70	45	60		193	183	175	160	143	122

PUMP DIMENSIONS

MODEL	DIMENSIONS (mm)						WEIGHT
	B1	B2	B1+B2	D1	D2	D3	
DL64-10-1	569	307	876	216	152	160	90
DL64-10	569	382	951	256	169	300	110
DL64-20-2	760	382	1142	256	169	300	130
DL64-20-1	760	505	1265	330	260	350	190
DL64-20	760	505	1265	330	260	350	192
DL64-30-2	862	505	1367	330	260	350	200
DL64-30-1	862	505	1367	330	260	350	202
DL64-30	862	560	1422	330	260	350	205
DL64-40-2	925	560	1485	330	260	350	210
DL64-40-1	925	590	1515	360	275	350	255
DL64-40	925	590	1515	360	275	350	257
DL64-50-2	1008	660	1668	400	305	400	315
DL64-50-1	1008	660	1668	400	305	400	317
DL64-50	1090	660	1750	400	305	400	319
DL64-60-2	1090	660	1750	400	305	400	320
DL64-60-1	1090	660	1750	400	305	400	340
DL64-60	1090	660	1750	400	305	400	342
DL64-70-2	1172	660	1832	400	305	400	345
DL64-70-1	1172	660	1832	400	305	400	347
DL64-70	1172	710	1882	450	305	450	410

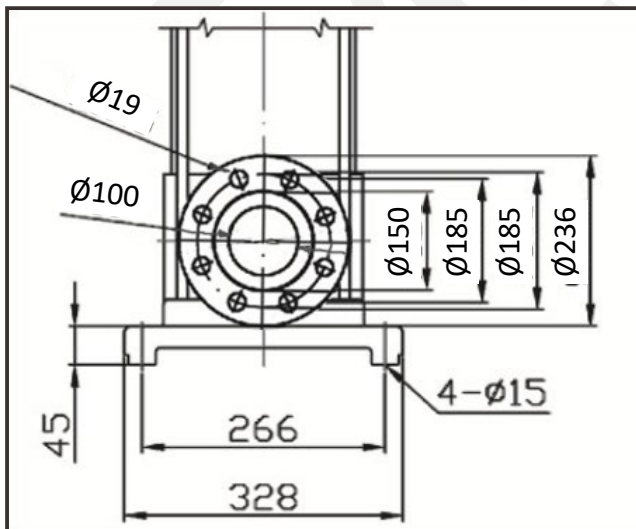
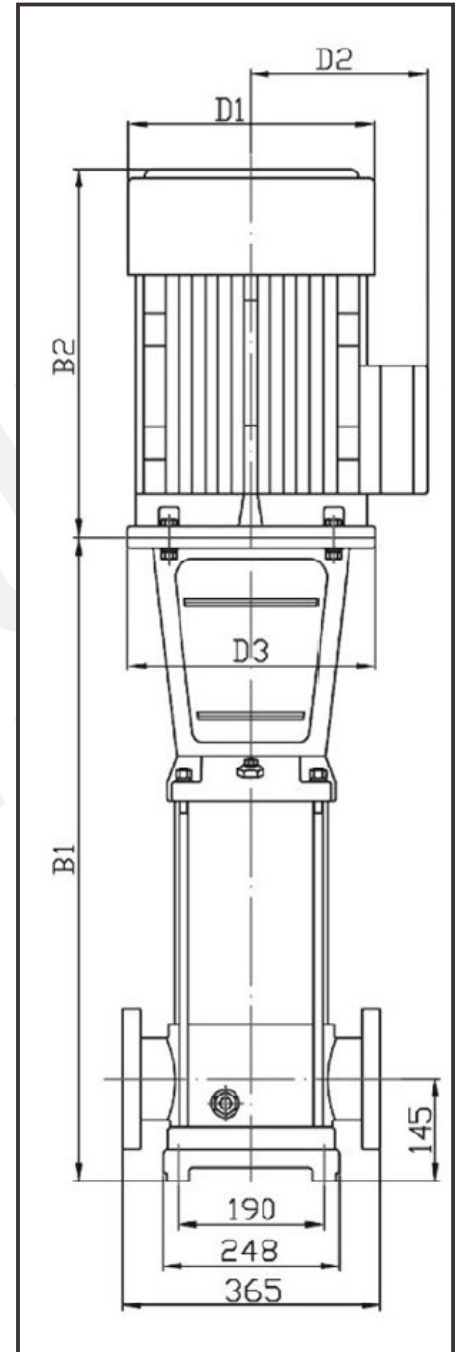

PERFORMANCE CURVES

DL90

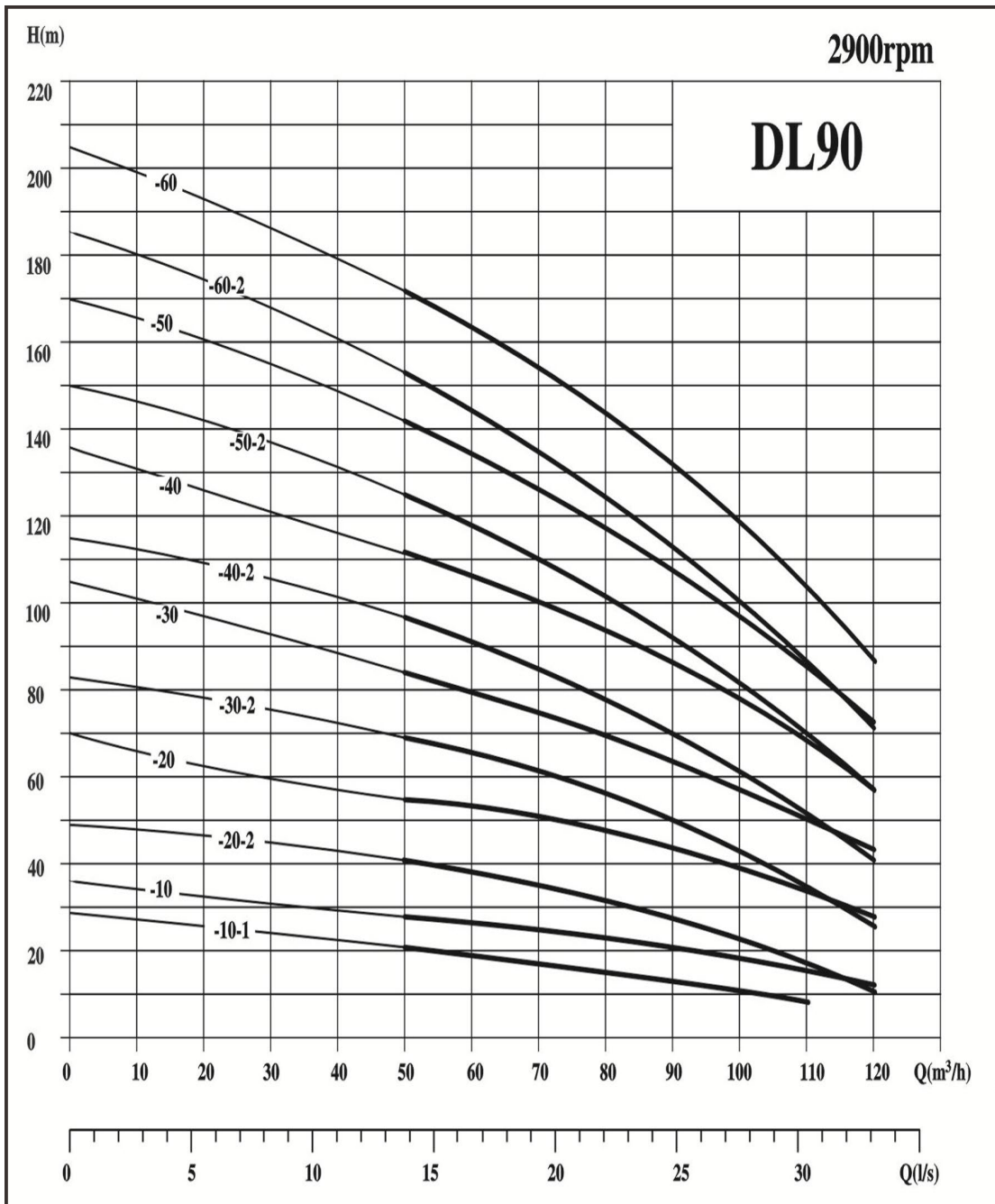

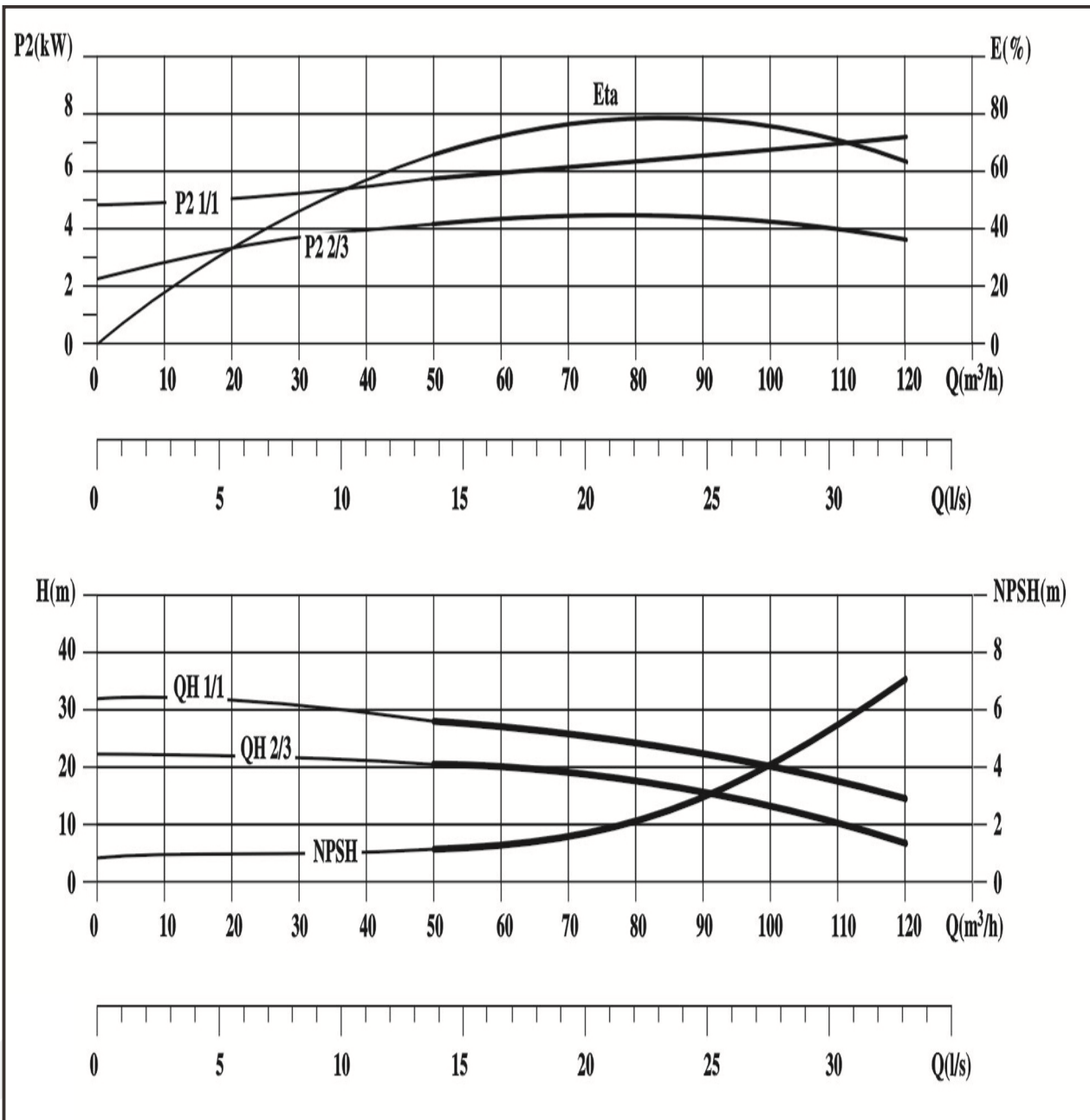

PERFORMANCE TABLE

DL90

MODEL	POWER		CAPACITY								
	kW	HP	m ³ /h	50	60	70	80	90	100	110	120
3 Phase 380V 50Hz					I/S	13.9	16.7	19.4	22.2	25	27.8
DL90-10-1	5.5	7.5	Head (m)	20.5	19	17.5	15.5	14	10	8	7
DL90-10	7.5	10		28	26.5	25	23.5	21	19	17.5	14.5
DL90-20-2	11	15		41	38	34	31	28	20	17.5	11.5
DL90-20	15	20		56	53	50	47	42	38	34	28
DL90-30-2	18.5	25		69	65	59	54.5	48.5	40	35	26.5
DL90-30	22	30		84	79.5	75	70.5	63	57	51	43.5
DL90-40-2	30	40		97	91	84	78	70	58	51.5	41
DL90-40	30	40		112	106	101	94	84	78	68	58
DL90-50-2	37	50		125	117.5	109	101.5	91	77	68.5	56
DL90-50	37	50		141	134	127	118	107	97	84	72
DL90-60-2	45	60		153	144	135	125	112	100	85.5	69
DL90-60	45	60		171	163	152	144	130	119	106	87

PUMP DIMENSIONS

MODEL	DIMENSIONS (mm)						WEIGHT
	B1	B2	B1+B2	D1	D2	D3	
DL90-10-1	573	382	955	256	169	300	105
DL90-10	573	382	955	256	169	300	120
DL90-20-2	775	505	1280	330	260	350	123
DL90-20	775	505	1280	330	260	350	205
DL90-30-2	867	560	1427	330	260	350	210
DL90-30	867	590	1457	360	275	350	255
DL90-40-2	959	660	1619	400	305	400	320
DL90-40	959	660	1619	400	305	400	323
DL90-50-2	1051	660	1711	400	305	400	340
DL90-50	1051	660	1711	400	305	400	343
DL90-60-2	1143	710	1853	450	305	450	410
DL90-60	1143	710	1853	450	305	450	413

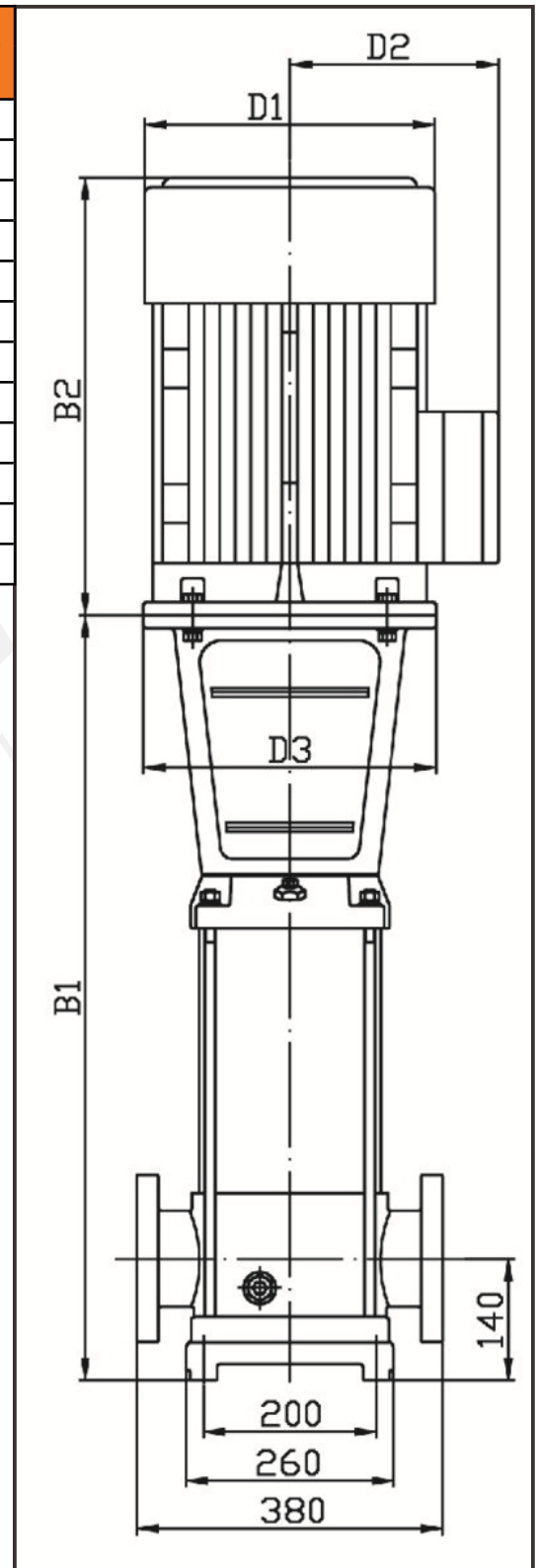
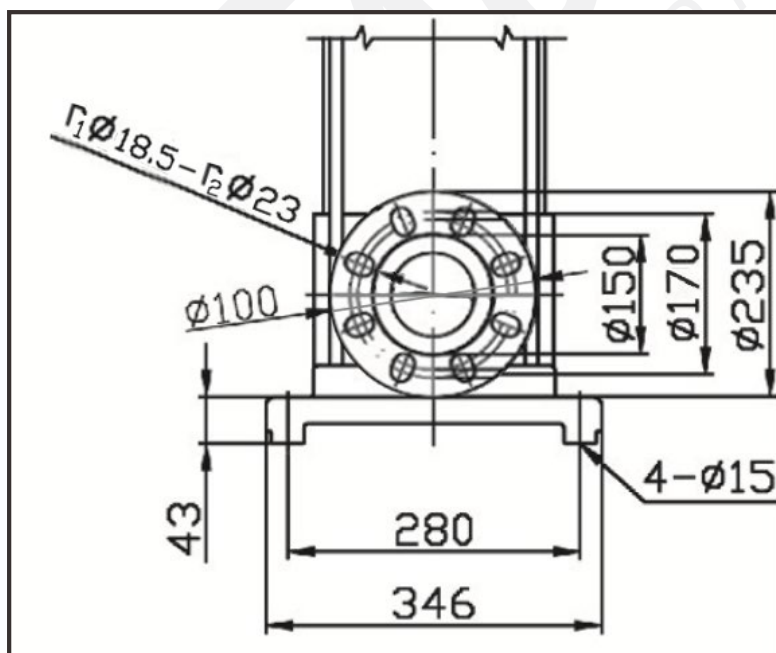

DL SINGLE PHASE

Flanged motor

Applications

These motors are suitable for the occasion requiring low starting torque and long-term continuous working, such as home electric appliances, pumps, fans, and recording meters, etc.

Features

Running dual capacitors

Frame Size:	71-90
Rated Power Range:	2 pole 0.37kW -2.2kW
House Material:	Aluminium (plastic terminal box)
Rated Voltage:	220V ± 5%, 50Hz
Protection Class:	IP54/IP55
Insulation Class:	Class B/F

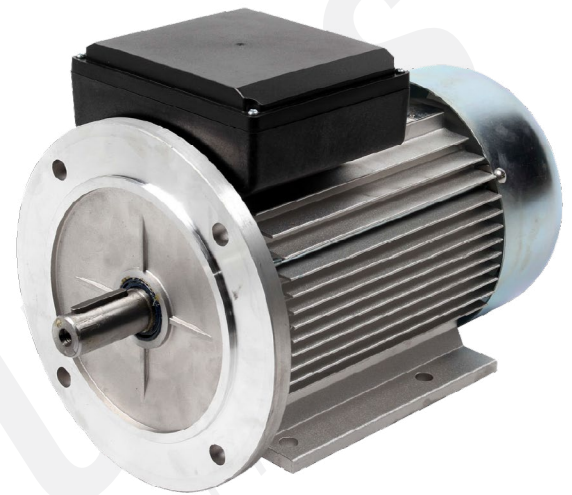

Performance data

FRAME SIZE	POWER (kW)	RATED SPEED (rpm)	CURRENT FULL LOAD 400V I _{FL} - 400V	CURRENT STARTING ÷ CURRENT FULL LOAD	EFFICIENCY %	POWER FACTOR	RATED TORQUE (Nm)	LOCKED ROTOR TORQUE ÷ TORQUE FULL LOAD	TORQUE BREAKDOWN ÷ TORQUE FULL LOAD	STARTING CAPACITOR 250V
71	0.37	2750	2.73	3.7	67	0.92	3.99	0.35	1.7	12
71	0.55	2760	3.88	3.9	70	0.92	5.94	0.35	1.7	16
80	0.75	2780	5.15	3.9	72	0.92	7.83	0.33	1.7	30
80	1.1	2790	7.02	4.3	75	0.95	11.48	0.33	1.7	35
90S	1.5	2800	9.44	4.8	76	0.95	15.57	0.30	1.7	40
90L	2.2	2800	13.7	4.8	77	0.95	22.47	0.30	1.7	40

Pumps up to 4kW require B14 flange and pumps from 5.5kW require B3/B5 flange.

OUTLINE AND INSTALLATION

Dimensions

FLANGE SPECIFICATION: B14

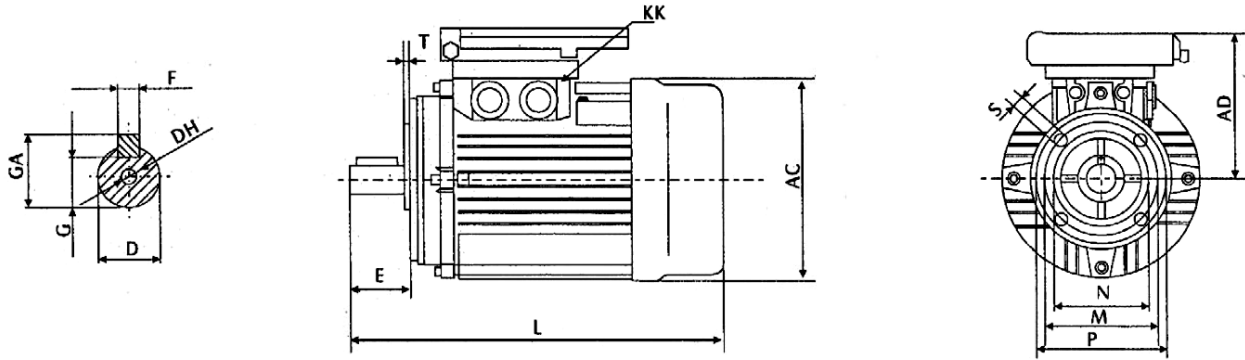

FRAME SIZE	A	AB	AC	AD	B	C	D	DH	E	F	G	H	R	K	KK	L	M	N	P	S	T	GA
71	112	136	138	110	90	45	14	M5X12	30	5	11	71	0+-1.0	7	2-M18X1.5	251	85	70	105	M6	3.5	16
80	125	154	157	152	100	50	19	M6X16	40	6	15.5	80	0+-1.5	10	2-M20X1.5	286	100	80	120	M6	3.5	21.5
90S	140	174	175	158	100	56	24	M8X19	50	8	20	90	0+-1.5	10	2-M20X1.5	335	115	95	140	M8	3.5	27
90L	140	174	175	158	125	56	24	M8X19	50	8	20	90	0+-1.5	10	2-M20X1.5	350	115	95	140	M8	3.5	27

FLANGE SPECIFICATION: B3

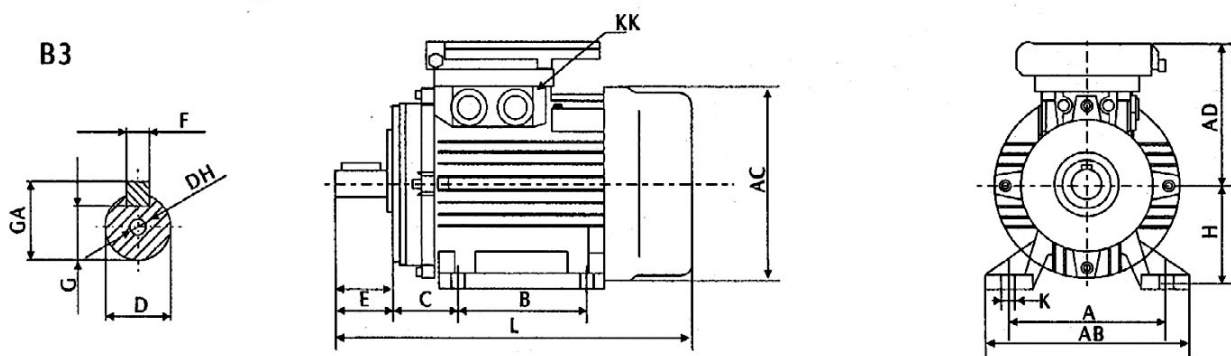

FRAME SIZE	A	AB	AC	AD	B	C	D	DH	E	F	G	H	K	KK	L	M	N	P	S	T	GA
71	112	136	138	110	90	45	14	M5X12	30	5	11	71	7	2-M18X1.5	251	130	110	160	9	3.5	16
80	125	154	157	152	100	50	19	M6X16	40	6	15.5	80	10	2-M20X1.5	286	165	130	200	12	3.5	21.5
90S	140	174	175	158	100	56	24	M8X19	50	8	20	90	10	2-M20X1.5	335	165	130	200	12	3.5	27
90L	140	174	175	158	125	56	24	M8X19	50	8	20	90	10	2-M20X1.5	350	165	130	200	12	3.5	27

FLANGE SPECIFICATION: B5

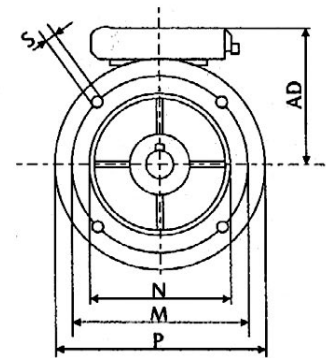
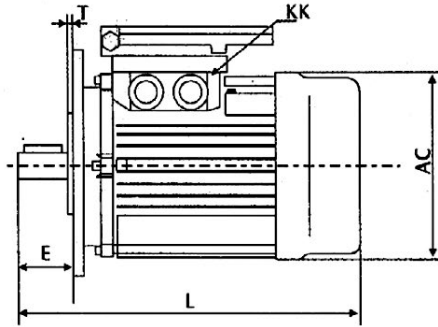
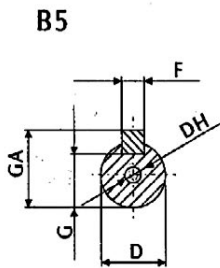

FRAME SIZE	A	AB	AC	AD	B	C	D	DH	E	F	G	H	K	KK	L	M	N	P	S	T	GA
71	112	136	138	110	90	45	14	M5X12	30	5	11	71	7	2-M18X1.5	251	130	110	160	9	3.5	16
80	125	154	157	152	100	50	19	M6X16	40	6	15.5	80	10	2-M20X1.5	286	165	130	200	12	3.5	21.5
90S	140	174	175	158	100	56	24	M8X19	50	8	20	90	10	2-M20X1.5	335	165	130	200	12	3.5	27
90L	140	174	175	158	125	56	24	M8X19	50	8	20	90	10	2-M20X1.5	350	165	130	200	12	3.5	27

DL THREE PHASE FLANGED

Motor Cast Iron

Features

- Frame Size Range: H80~H355
- Housing Material: Frame, flange and bracket, grey cast iron, conduit box-steel
- Standard Mounting Construction: IEC60034-7 Protect
- Enclosed Class: IP55 (IEC60034-5)
- Cooling Method: IC411 (IEC60034-6)



The special winding design can work for multi-voltages (50Hz or 60Hz)
 Can withstand 1.5 times of the rated current for 2 minutes (IEC60034-1)
 Anti-condensation heater is available.
 PTC or Pt100 thermistor are available to protect the winding and bearing.

Standard 3-phase motors can be connected using the star of delta method.

Star connection is achieved by wiring W2,U2, V2 to each other; and U1, V1, W1 leads to voltage supply.

Delta connection is achieved by wiring the end of a phase to the head of another.

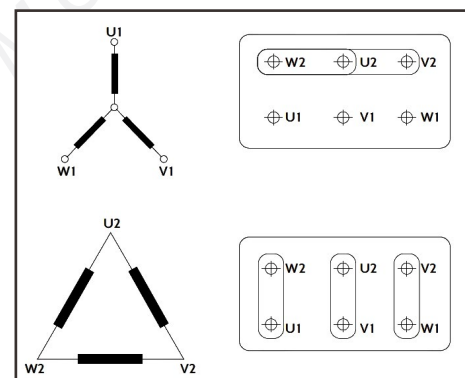

Insulation classification

The motors have insulation class F while the temperature rise is for class B ensuring a longer service life. Class H insulation motors can be manufactured at the customer's request. Under specified measuring conditions in accordance with IEC 60034-1 standard, insulation class F for an electric motor means that at the ambient temperature of 40°C the temperature rise of its windings may be maximum 165K with the additional temperature margin of 10K.

	155°C	15	Temperature Margin
130°C	10		Max. Temp. Rise
80	105	125	
40	40	40	Ambient Temperature
B	F	H	

Degree of protection

According to IEC 60034-5 standard, electric motors are provided with IP code which determines the degree of protection ensured by the housing against access to dangerous parts, introducing foreign matter and/or water.

Our motors comply with IP55 protection class as standard.

THE FIRST CHARACTERISTIC NUMERAL: PROTECTION FORM INTRODUCTION OF SOLID FOREIGN MATTER		THE SECOND CHARACTERISTIC NUMERAL: PROTECTION AGAINST PENETRATION OF WATER AND ITS HARMFUL EFFECTS	
0	Non-protected machine	0	Non-protected machine
1	Machine protected against solid objects greater than 50mm	1	Machine protected against dripping water
2	Machine protected against solid objects greater than 12mm	2	Machine protected against dripping water when tilted up to 15°
3	Machine protected against solid objects greater than 2.5mm	3	Machine protected against spraying water
4	Machine protected against solid objects greater than 1mm	4	Machine protected against splashing water
5	Dust protected machine	5	Machine protected against water jets
6	Dust-tight machine	6	Machine protected against heavy seas

Number of starts per hour

The number of starts per hour is dependant on the inertia of the driven load and the load torque demand. A guide to generally acceptable starts per hour would be as per table.

STARTS PER HOUR	
FRAME SIZE	2 POLE
80	20
90	16
100	16
112	16
132	10
160	10
180	8
200	6
225	5

Bearings

FRAME SIZE	DRIVING END	NON DRIVING END
	2 POLE	2 POLE
80	6205 2Z/C3	6205 2Z/C3
90	6206 2Z/C3	6206 2Z/C3
100	6206 2Z/C3	6206 2Z/C3
112	6207 2Z/C3	6207 2Z/C3
132	6208 2Z/C3	6208 2Z/C3
160	6209 2Z/C3	6209 2Z/C3
180	6211/C3	6211/C3
200	6212/C3	6212/C3
225	6212/C3	6212/C3

PERFORMANCE DATA

FRAME SIZE	POWER (kW)	RATED SPEED (rpm)	CURRENT FULL LOAD 380V	CURRENT FULL LOAD 400V	CURRENT FULL LOAD 415V	EFFICIENCY %	POWER FACTOR	RATED TORQUE (Nm)	TORQUE STARTING ÷ TORQUE FULL LOAD	TORQUE MAXIMUM ÷ TORQUE FULL LOAD	NOISE LEVEL LW db(A)	NET WEIGHT kg
80	0.75	2840	1.8	1.7	1.67	75.5	0.83	2.5	2.3	2.6	67	14
80	1.1	2840	2.6	2.5	2.4	76.2	0.84	3.7	2.3	2.6	67	15
90S	1.5	2850	3.4	3.2	3.1	79.5	0.85	5	2.5	2.9	72	20
90L	2.2	2850	4.8	4.6	4.4	81.7	0.85	7.4	2.7	2.9	72	24
100L	3	2880	6.3	6	5.8	83.1	0.87	10	2.7	2.9	76	30
112M	4	2880	8.2	7.8	7.6	84.2	0.88	13.3	2.6	2.9	77	38
112M	5.5	2880	11.1	10.5	10.2	85.7	0.88	13.3	2.7	3.2	78	43
132S	5.5	2900	11.1	10.5	10.2	85.9	0.88	18.1	2.3	2.6	80	57
132S	7.5	2900	16.9	14.2	13.5	87.2	0.88	24.5	2.5	2.8	80	61
160M	11	2930	21.1	20.1	19.4	88.7	0.89	35.8	2.6	2.9	86	101
160M	15	2930	28.6	27.2	26.2	89.5	0.89	48.8	2.6	2.9	86	111
160L	18.5	2930	34.6	32.9	31.8	90.2	0.90	60.4	2.5	2.8	86	126
180M	22	2940	41	38.9	37.6	90.6	0.90	71.4	2.6	2.8	89	176
200L	30	2950	55.4	52.6	50.7	91.5	0.90	97.2	2.5	2.7	92	226
200L	37	2950	67.9	64.5	62.2	92.0	0.90	119.8	2.4	2.6	92	245
225M	45	2970	82.1	78	75.3	82.5	0.90	144.8	2.4	2.6	92	280

OUTLINE AND INSTALLATION

Dimensions

FLANGE SPECIFICATION: B3B5

B3/5

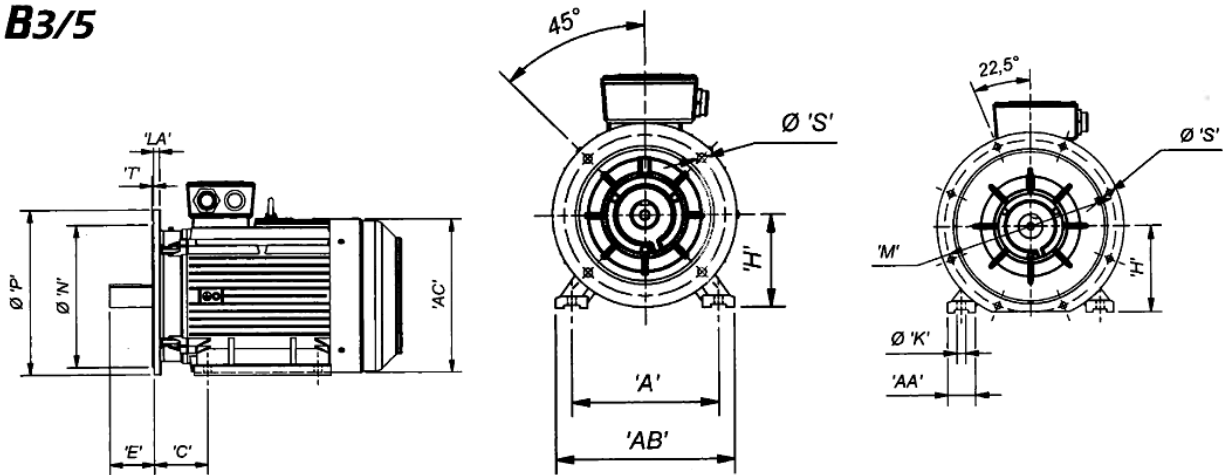

FRAME SIZE	A	AA	AB	AC	C	E	H	ØK	LA	ØM	ØN	ØP	T	ØS	NO OF HOLES
80	125	34	156	175	50	40	80	10	12	165	130	200	3.5	12	4
90S	140	36	176	190	56	50	90	10	12	165	130	200	3.5	12	4
90L	140	36	176	190	56	50	90	10	12	165	130	200	3.5	12	4
100L	160	40	198	215	63	60	100	12	14	215	180	250	4	15	4
112M	190	45	226	236	70	60	112	12	14	215	180	250	4	15	4
132S	216	52	260	275	89	80	132	12	14	265	230	300	4	15	4
160M	254	65	314	330	108	110	160	14.5	16	300	250	350	5	19	4
160L	254	65	314	330	108	110	160	14.5	16	300	250	350	5	19	4
180M	279	70	345	380	121	110	180	14.5	16	300	250	350	5	19	4
200L	318	70	388	420	133	110	200	18.5	18	350	300	400	5	19	4
225M	356	75	431	465	149	110	225	18.5	20	400	350	450	5	19	8

Dimensions

FLANGE SPECIFICATION: B14

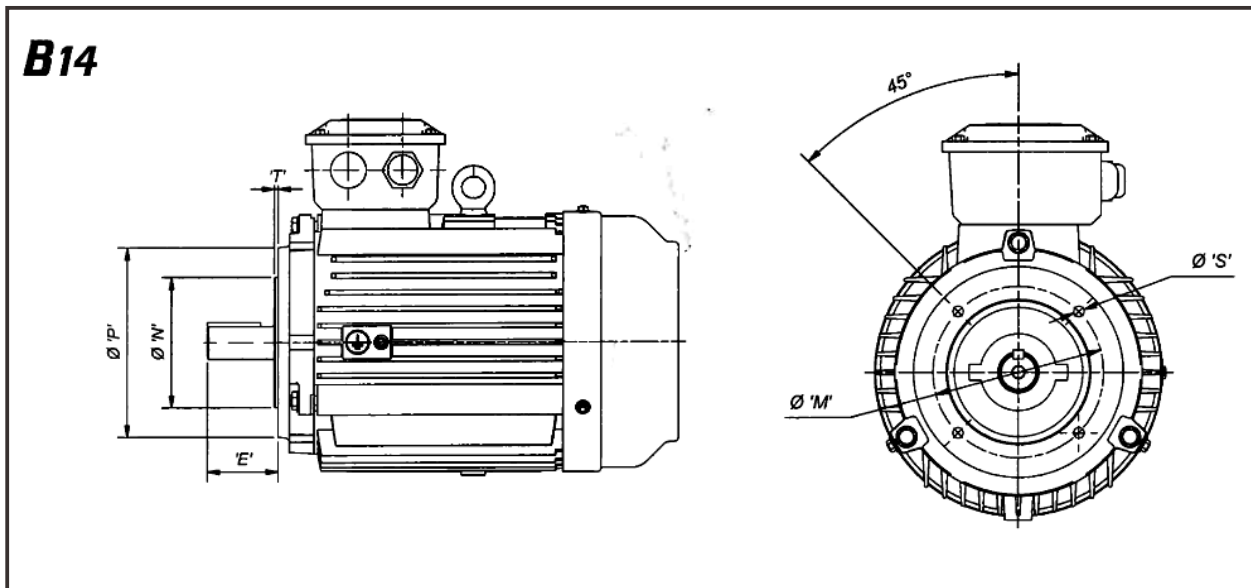

FRAME SIZE	E	ØM	ØN	ØP	T	S	NO OF HOLES
80	40	100	80	120	3	M6	4
90S	50	115	95	140	3	M8	4
90L	50	115	95	140	3	M8	4
100L	60	130	110	160	3.5	M8	4
112M	60	130	110	160	3.5	M8	4
132S	80	165	130	200	3.5	M10	4
160M	110	215	180	248	4	M12	4
160L	110	215	180	248	4	M12	4

DL THREE PHASE FLANGED

Motor Aluminium

Features

Three-phase removable feet standard efficiency aluminium induction motors. Position of the terminal box can be changed according to the user's requirements. Efficiency indicator reaches IE1 standard.

Characteristics for all standard 3-phase aluminium induction motors are as follows:

1. IP55 protection, class F insulation, B temperature rise and S1 duty.
2. Rated voltage 400V or 525V, rated frequency 50Hz.
3. Y-connection for motors up to 3kW and Δ - connection for 4kW and above.
4. Cooling method is Ic411.

Operating conditions

Ambient temperature: -200C to 400C.

Altitude: <1000m

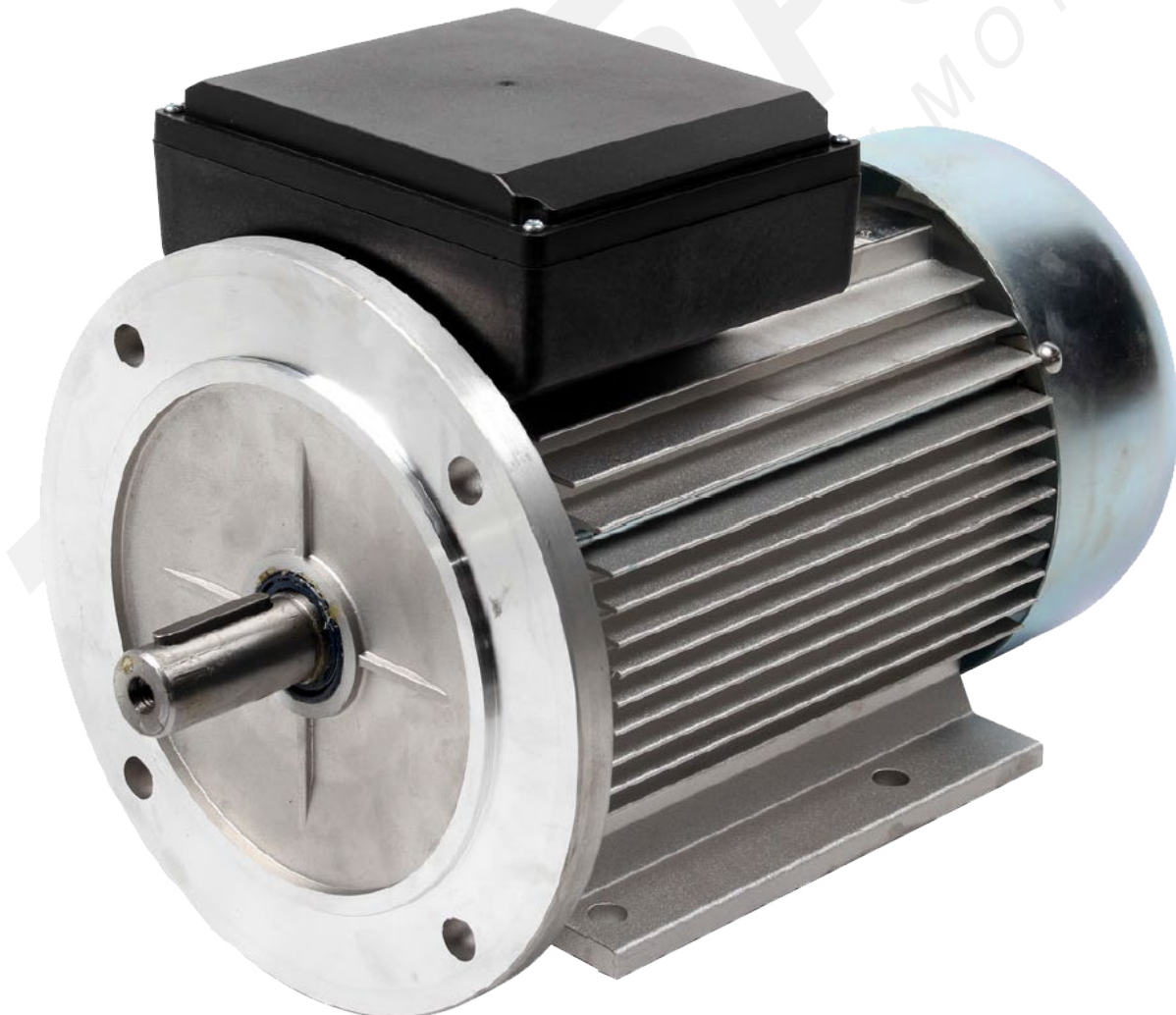

PERFORMANCE DATA

FRAME SIZE	POWER (kW)	RATED SPEED (rpm)	CURRENT FULL LOAD I_n (A)	FULL LOAD POWER FACTOR COS ϕ	EFFICIENCY $\eta\%$ OF % FULL LOAD			LOCKED ROTOR ÷ CURRENT Is/In	LOCKED ROTOR ÷ TORQUE Ms/Mn	BREAKDOWN ÷ TORQUE Mk/Mn	RATED TORQUE Nm	MOMENT OF INERTIA J(K- gm ²)	NETT WEIGHT kg
					100	75	50						
71	0.37	2760	0.94	0.81	70.0	70.9	68.9	6.1	2.2	2.2	1.28	0.0005	6.2
71	0.55	2820	1.33	0.82	73.0	73.9	71.9	6.1	2.2	2.3	1.86	0.00063	6.3
80	0.75	2845	1.76	0.83	74.0	74.2	71.4	6.1	2.4	2.5	2.52	0.0008	8.3
80	1.1	2840	2.49	0.84	76.0	76.8	75.3	7.0	2.5	2.5	3.7	0.0010	9.0
90S	1.5	2840	3.30	0.84	78.0	78.7	76.7	7.0	2.7	2.8	5.04	0.0012	12.5
90L	2.2	2840	4.67	0.85	80.0	80.8	79.5	7.0	2.5	2.8	7.4	0.0014	14.0
100L	3	2870	6.07	0.87	82.0	82.1	80.3	7.5	2.2	2.5	9.98	0.0029	20.5
112M	4	2880	7.81	0.88	84.0	84.8	84.1	7.5	2.3	2.3	13.26	0.0050	26.0
132S	5.5	2910	10.6	0.88	85.0	85.0	83.5	7.5	2.2	2.5	18.11	0.0104	40.0
132S	7.5	2905	14.3	0.88	86.3	86.6	85.6	7.5	2.2	2.4	24.66	0.0121	44.0

OUTLINE AND INSTALLATION

Dimensions

FLANGE SPECIFICATION: B5

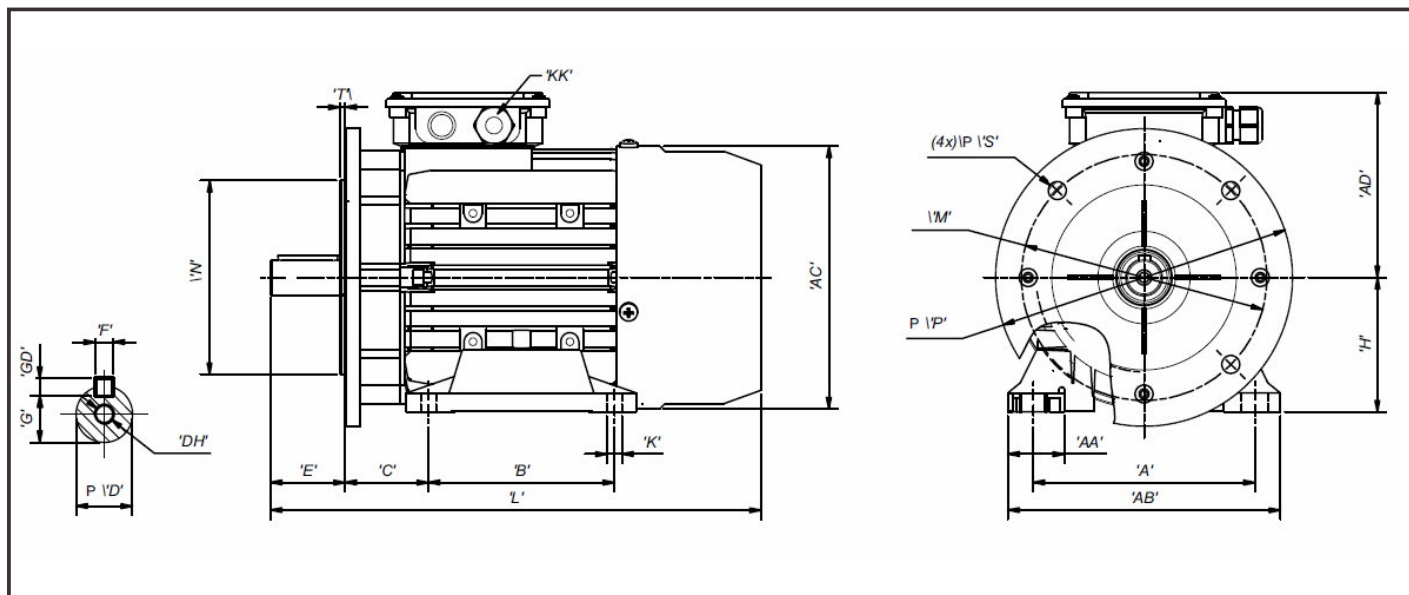

FRAME SIZE	kW	MOUNTING DIMENSIONS (mm)															
		AC	AD	D	DH	E	F	G	GD	KK	L	M	N	P(max)	S(min)	T	kg
71	0.37	138	109	14	M5x12	30	5	16	5	M20x1.5	245	130	110	160	10	3.5	6.2
71	0.55	138	109	14	M5x12	30	5	16	5	M20x1.5	245	130	110	160	10	3.5	6.3
80	0.75	157	112	19	M6x16	40	6	21.5	6	M20x1.5	275	160	130	200	12	3.5	8.3
80	1.1	157	112	19	M6x16	40	6	21.5	6	M20x1.5	275	160	130	200	12	3.5	9.0
90S	1.5	175	123	24	M8x19	50	8	27	7	M20x1.5	315	165	130	200	12	3.5	12.5
90L	2.2	175	123	24	M8x19	50	8	27	7	M20x1.5	330	165	130	200	12	3.5	14.0
100L	3.0	196	139	28	M10x22	60	8	31	7	M20x1.5	370	215	180	250	15	4	20.5
112M	4.0	220	156	28	M10x22	60	8	31	7	M25x1.5	395	215	180	250	15	4	26.0
132S	5.5	260	185	38	M12x28	80	10	41	8	M25x1.5	472	265	230	300	15	4	40.0
132S	7.5	260	185	38	M12x28	80	10	41	8	M25x1.5	472	265	230	300	15	4	44.0

OUTLINE AND INSTALLATION

Dimensions

FLANGE SPECIFICATION: B14

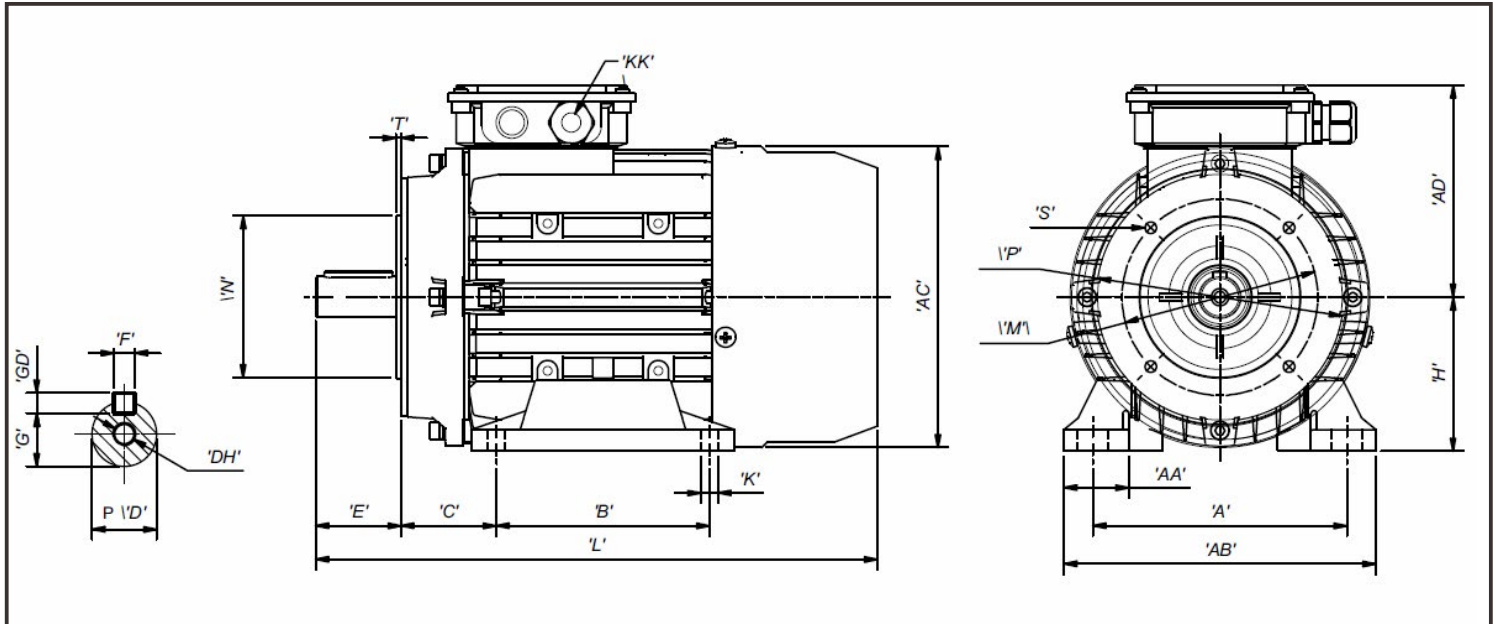

FRAME SIZE	kW	MOUNTING DIMENSIONS (mm)															
		AC	AD	D	DH	E	F	G	GD	KK	L	M	N	P(max)	S(min)	T	kg
71	0.37	138	109	14	M5x12	30	5	16	5	M20x1.5	245	85	70	105	M6	2.5	6.2
71	0.55	138	109	14	M5x12	30	5	16	5	M20x1.5	245	85	70	105	M6	2.5	6.3
80	0.75	157	112	19	M6x16	40	6	21.5	6	M20x1.5	275	100	80	120	M6	3	8.3
80	1.1	157	112	19	M6x16	40	6	21.5	6	M20x1.5	275	100	80	120	M6	3	9.0
90S	1.5	175	123	24	M8x19	50	8	27	7	M20x1.5	315	115	95	140	M8	3	12.5
90L	2.2	175	123	24	M8x19	50	8	27	7	M20x1.5	330	115	95	140	M8	3	14.0
100L	3.0	196	139	28	M10x22	60	8	31	7	M20x1.5	370	130	110	160	M8	3.5	20.5
112M	4.0	220	156	28	M10x22	60	8	31	7	M25x1.5	395	130	110	160	M8	3.5	26.0
132S	5.5	260	185	38	M12x28	80	10	41	8	M25x1.5	472	165	130	200	M10	3.5	40.0
132S	7.5	260	185	38	M12x28	80	10	41	8	M25x1.5	472	165	130	200	M10	3.5	44.0