

# BOREHOLE RANGE

8VP

**TRACER PUMPS**

LEADING IN MOTION



24-01

# 8VP BOREHOLE RANGE (8")

## 8VP-80 & 8VP-98



### Pump features

The 8VP range features high efficiency, class leading rigidity and increased pressure for large scale pressure and flow characteristics.

### Operating range

These pumps are designed for agricultural & mining applications.

Head range:	7m - 400m
Flow rate:	20 - 120m <sup>3</sup> /h
Minimum immersion:	1m
Maximum sand content:	50g/m <sup>3</sup>

### Key materials

Suction, stage casing and discharge outlets:	stainless steel 304
Impellers:	stainless steel 304
Pump shaft:	SS AISI 431
Bearing bush:	anti friction rubber
Non return valve:	stainless steel 304
Cable guard and strainer:	stainless steel 304

Pump and motor couplings are as per NEMA standards.

# 8VP BOREHOLE RANGE (8")

## 8VP-80 & 8VP-98

### Material specifications

NO.	PART NAME	MATERIAL	STANDARD
1	DCH Sleeve	Stainless Steel	304
2	Clamping Strip	Stainless Steel	304
3	Spring	Stainless Steel	304
4	Valve guide rib assembly	Stainless Steel	304
5	Valve assembly	Stainless Steel	304
6	Valve seat housing	Stainless Steel	304
7	First stage bearing bush	Stainless Steel + NBR	304
8	Stop ring	Stainless Steel	304
9	Spacing washer	25% CFT	304
10	First stage nut	Stainless Steel	304
11	Impeller Collet	Stainless Steel	304
12	Bearing bush stage	NBR	
13	Collet Nut	Stainless Steel	304
14	Neckring	NBR + PPS	
15	IMC Sleeve	Stainless Steel	304
16	Intermediate Chamber	Stainless Steel	304
17	Impeller Assembly	Stainless Steel	304
18	Cable guard	Stainless Steel	304
19	Shaft	Stainless Steel	431
20	Strainer	Stainless Steel	304
21	NEMA Coupling	Stainless Steel	304
22	Suction Inter-connector	Stainless Steel	304

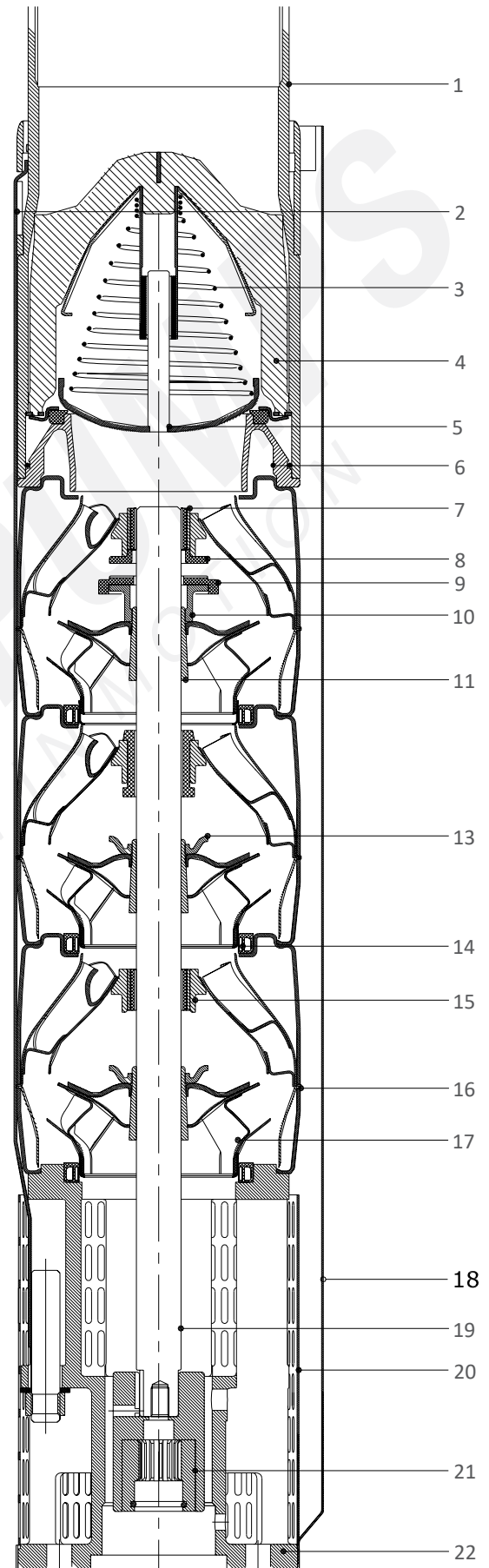

# 8VP BOREHOLE RANGE (8")

## 8VP-80

### Performance Curve

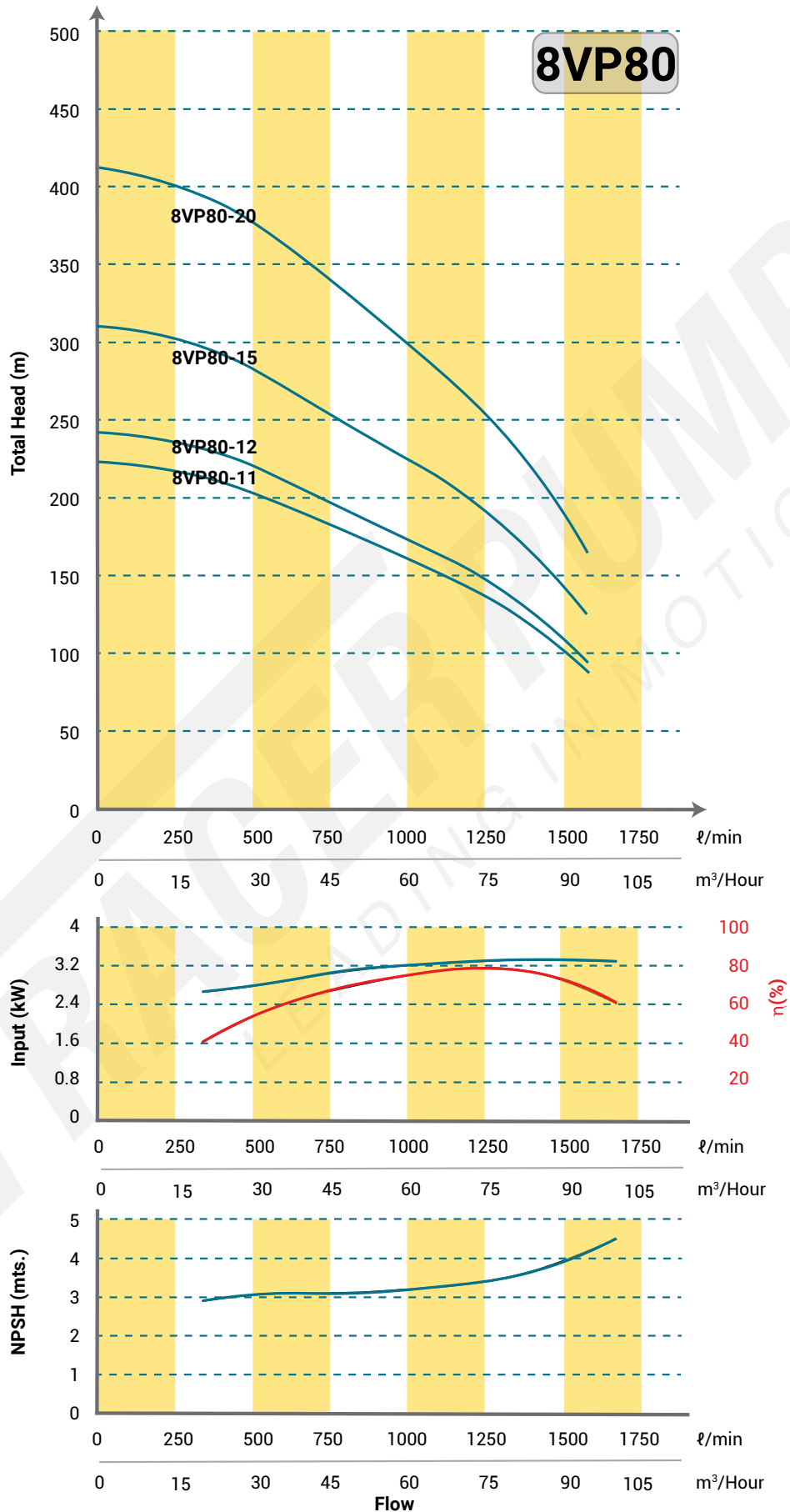

# 8VP BOREHOLE RANGE (8")

## 8VP-80

### Performance chart

Model	Stage	kW	HP	l/min	0	335	500	670	835	1000	1170	1335	1500	1670
				m <sup>3</sup> /h	0	20.0	30.0	40.2	50.1	60.0	70.2	80.1	90.0	100.0
8VP 80-11	11	37.00	50.00	HEAD	226	217	206	192	177	163	149	133	110	80
8VP 80-12	12	45.00	60.00		246	237	225	209	193	178	163	145	120	88
8VP 80-15	15	55.00	75.00		308	296	281	262	242	223	203	181	150	110
8VP 80-20	20	75.00	100.0		410	395	375	349	322	297	271	241	200	146

### Dimensions & Weights

MODEL NAME	D (mm)	L (mm)	G (mm)	Pump Weight (kg)
8VP 80-11	175	1900	125	59
8VP 80-12	175	2028	125	63
8VP 80-15	196	2412	125	75
8VP 80-20	196	3052	125	95

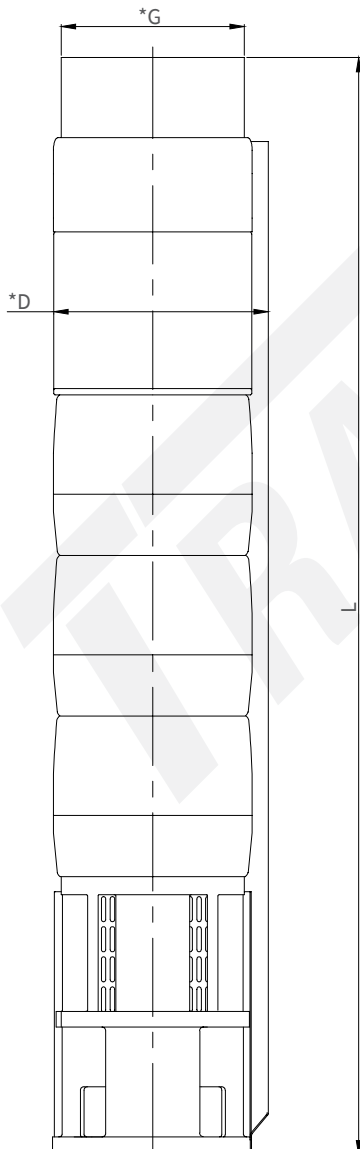

- \* G: Available Outlet Size BSP 5"
- \* D: Maximum Diameter With Single Cable Guard

# 8VP BOREHOLE RANGE (8")

## 8VP-98

### Performance Curve

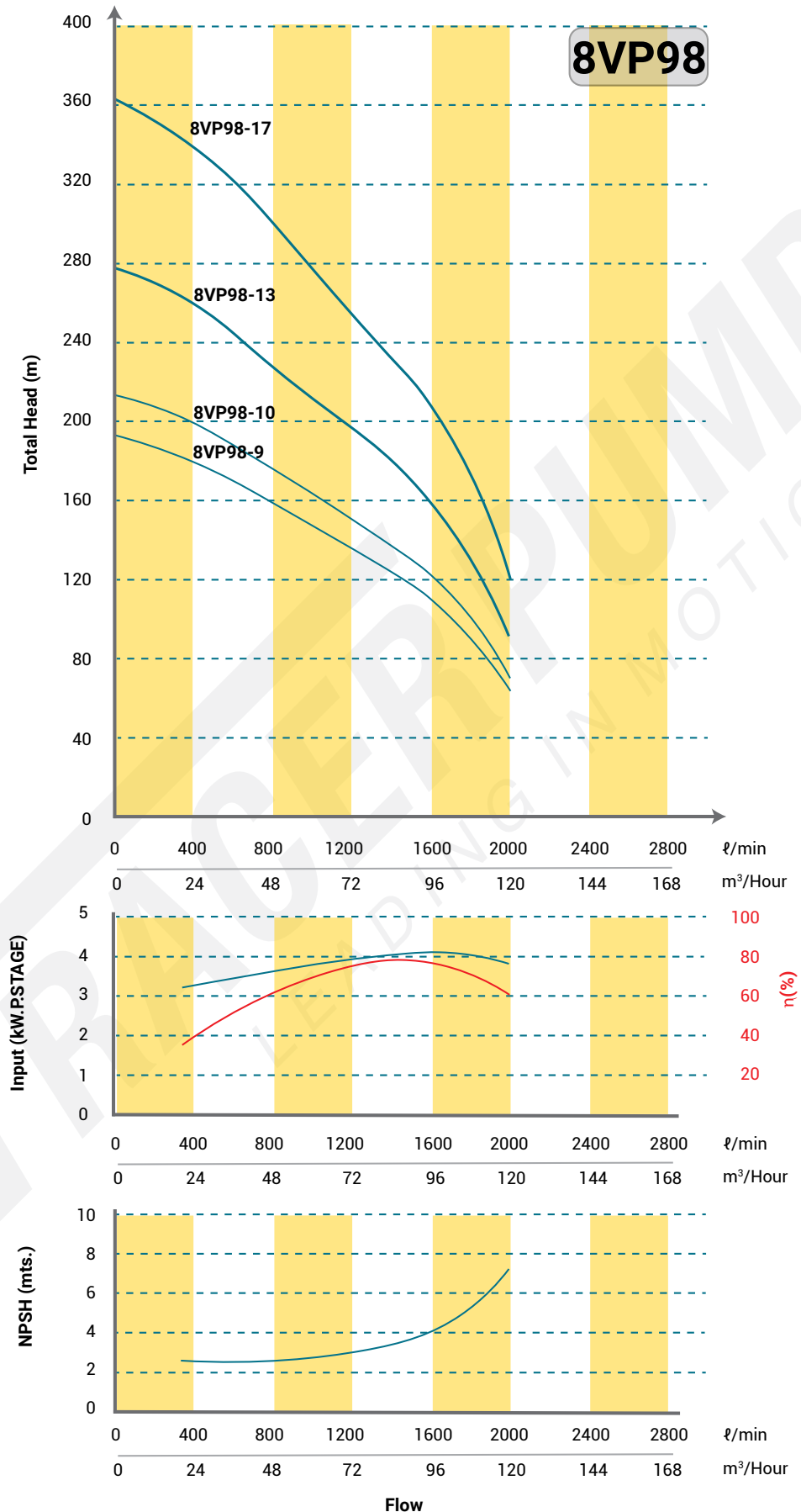

# 8VP BOREHOLE RANGE (8")

## 8VP-98

### Performance chart

Three Phase	Stage	kW	HP	l/min	0	335	675	1010	1170	1335	1500	1670	1835	2000
					m <sup>3</sup> /h	0	20.0	40.5	60.6	70.2	80.1	90.0	100.2	110.1
8VP 98-09	9	37.00	50	HEAD	193	185	166	146	137	128	118	104	85	63
8VP 98-10	10	45.00	60.00		214	205	184	162	152	142	131	115	94	70
8VP 98-13	13	55.00	75.00		278	267	239	210	197	185	171	150	122	92
8VP 98-17	17	75.00	100.0		364	349	313	275	258	242	223	196	160	120

### Dimensions & Weights

MODEL NAME	D (mm)	L (mm)	G (mm)	Pump Weight (kg)
8VP 98-09	175	1644	125	53
8VP 98-10	175	1772	125	55
8VP 98-13	196	2156	125	67
8VP 98-17	196	2668	125	83

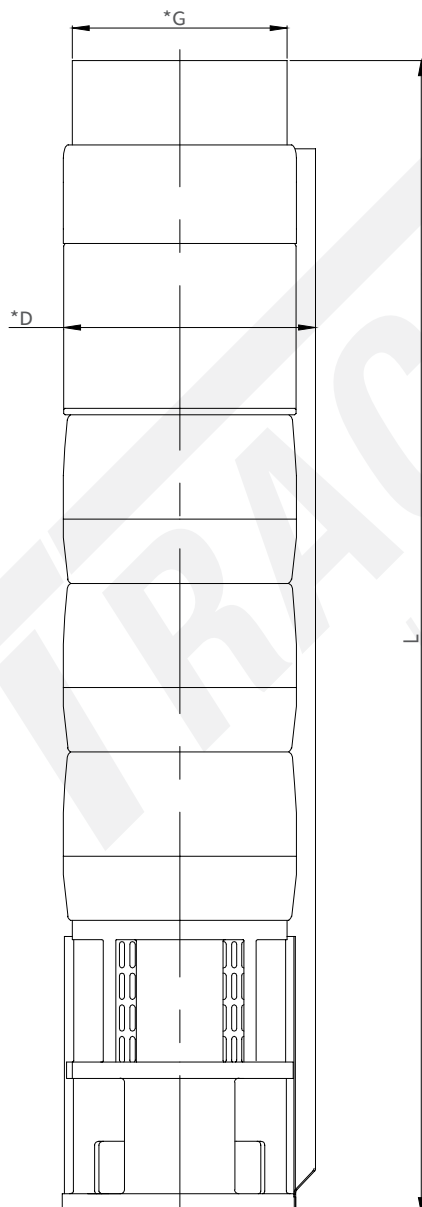

- \* G: Available Outlet Size BSP 5"
- \* D: Maximum Diameter With Single Cable Guard

# 8" SUBMERSIBLE MOTOR

## WATER FILLED

### Technical specification

8" Water lubricated submersible motor

Coupling dimensions as per NEMA standard.

Voltage:	380-415V & 525V 50Hz
Winding wire:	Polywrapped
Protection:	IP68
Max water temperature:	35 °C
Max starts per hour:	20
Allowable voltage variation:	+6% - 10%
Motor shaft:	Stainless steel
Stator shell:	Stainless steel
Max immersion:	350m
Mounting:	vertical / up to 15 ° above horizontal
Cable:	3m X 4 core

### Material specification

NO	PART NAME	MATERIAL
01	Cable 4 core	EPR
02	Oil seal	N.B.R
03	Adapter	CAST IRON(FG-200)
04	Upper housing	CAST IRON(FG-200)
05	Bearing bush	LTB-4 (2% Ni) / M.S-N.B.R
06	Robot shaft	S.S.431
07	Motor shell	S.S.304
08	Lower housing	CAST IRON (FG-200)
09	Bearing bush	LTB-4 (2% Ni) / M.S-N.B.R
10	Thrust bearing set	CARBON / S.S.420
11	Pressure cup	H.B.R
12	Motor base	CAST IRON (FG-200)
13	All hardware	S.S.304

Pn		Weight	
kW	HP	Nett (kg)	Gross (kg)
45	60	165	183.4
55	75	205	223
75	100	220	245

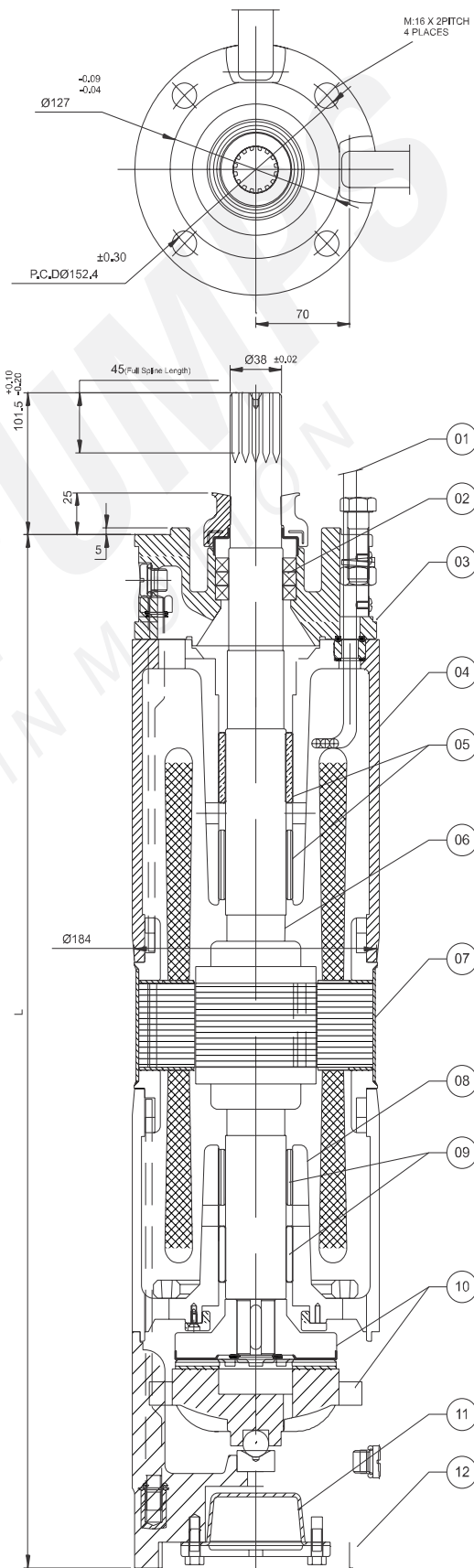



# 8" SUBMERSIBLE MOTOR

## WATER FILLED

### Technical data

#### 380V

TYPE	HP	kW	AMPS			Hz	RPM			COS O			CONN.	THRUST LOAD	WIND	COOLING FLOW m/sec	MAX WATER TEMP.	CABLE
			380 V	400 V	415 V		380 V	400 V	415 V	380 V	400 V	415 V						
V8	60	45	92.9	90	88	50	2895	2910	2910	0.88	0.86	0.85	Delta (I)	45000	PW	0.5	35	SINGLE
V8	75	55	115	110	109	50	2910	2915	2920	0.88	0.85	0.85	Delta (I)	45000	PW	0.5	35	SINGLE
V8	100	75	152	147	145	50	2890	2910	2910	0.88	0.85	0.85	Delta (I)	45000	PW	0.5	35	SINGLE

#### 525V

TYPE	HP	kW	AMPS			Hz	RPM			COS O			CONN.	THRUST LOAD	WIND	COOLING FLOW m/sec	MAX WATER TEMP.	CABLE
			480 V	500 V	525 V		480V	500V	525V	480V	500V	525V						
V8	60	45	74	67	67	50	2880	2890	2900	0.81	0.82	0.84	Delta (I)	45000	PW	0.5	35	SINGLE
V8	75	55	75	68	68	50	2881	2892	2900	0.81	0.8	0.83	Delta (I)	45000	PW	0.5	35	SINGLE
V8	100	75	76	70	70	50	2882	2890	2900	0.81	0.8	0.84	Delta (I)	45000	PW	0.5	35	SINGLE

### Exploded drawing

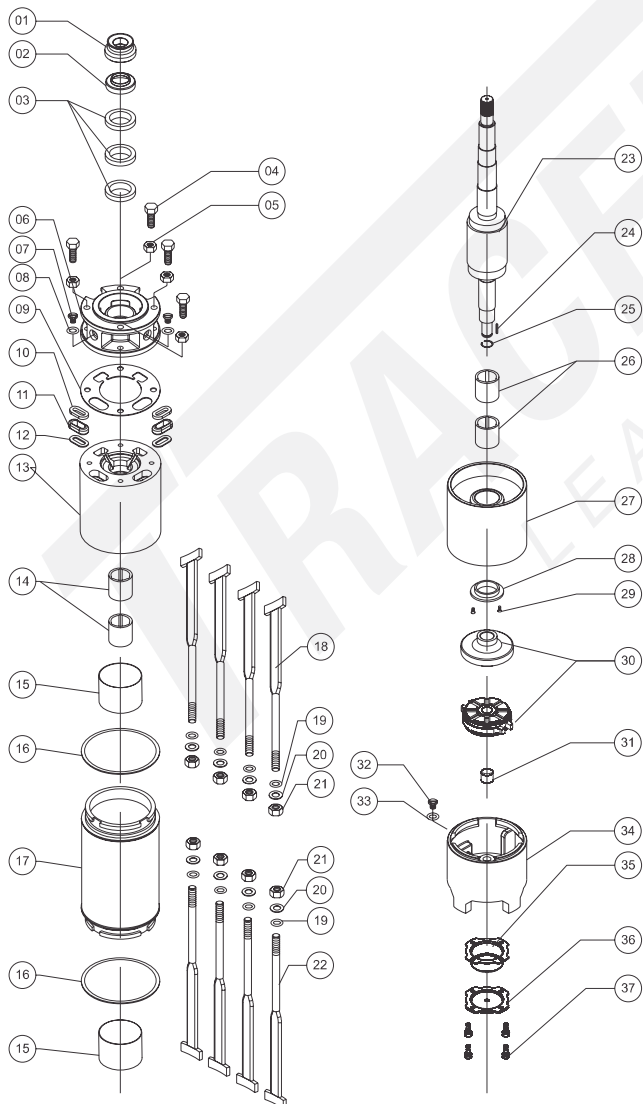

1	Sand Guard
2	Upper Cap
3	Oil Seal
4	Hex Bolt
5	Hex Nut
6	Adapter
7	Drain Plug
8	Drain Plug O-ring
9	Paper Gasket
10	Grommet Washer
11	Grommet
12	Grommet Washer
13	Upper Housing
14	Bearing Bush
15	Winding Cap
16	Paper Gasket
17	Stator Body
18	T-bolt Washer

19	T-bolt O-ring
20	T-bolt Washer
21	Hex Nut
22	T-bolt
23	Rotor
24	Rotor Key
25	Rotor Cir Clip
26	Bearing Bush
27	Lower Housing
28	Fiber C.T Bearing
29	Screw
30	Counter Bearing Set
31	Fix Rocker
32	Drain Plug
33	Motor Base
34	Pressure Cupe
35	Drain Plug
36	Motor Baseplate