

# CENTRIFUGAL RANGE

CPM HIGH FLOW



***TRACER PUMPS***

LEADING IN MOTION

2023 V2

# SINGLE STAGE PUMPS

## CPM

### Range of performance

Flow rate: max 416 L/min (25m<sup>3</sup>/h)  
Head: max 30m

### Limits of use

Suction lift: max 7m  
Liquid temperature: 40°C  
Ambient temperature: 40°C

### Uses and installations

They are recommended for pumping clean water without abrasive particles and liquids that are chemically non aggressive for the materials of which the pump is made. Due to their reliability, simplicity of use and economy, they are suitable for high flow requirements & specifically for centre pivot/greenhouse irrigation. The pump must be installed under a vented cover and protected against exposure to rain or water spray.



### Construction Characteristics

Pump Body: Cast Iron  
Impeller: Brass  
Motor Shaft: Stainless Steel 304  
Mechanical Seal: Ceramic-graphite  
Electric Motor: Single-phase 230V - 50Hz with capacitor and thermal overload protector.  
CP: three-phase 380/400v -50Hz  
Insulation: Class B  
Protection: IP 44

### Diagram

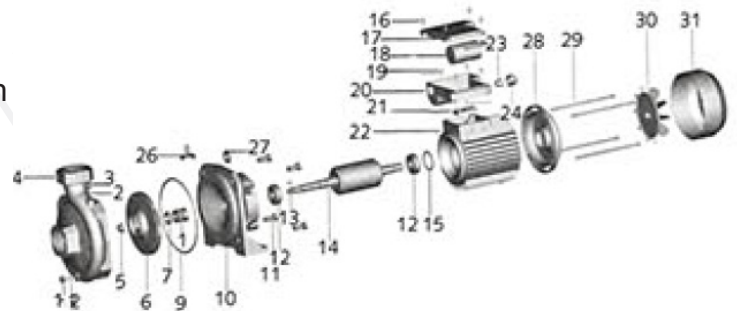

### Diagram

No.	Description	No.	Description	No.	Description	No.	Description
1	Water vent screw	9	O-Ring	17	Terminal cover	25	Screw
2	O-Ring	10	Pump Support	18	Capacitor	26	Stand
3	Air vent screw	11	Bolt	19	Screw	27	Drop guard
4	Pump body	12	Bearing	20	Terminal box	28	Driving cap
5	Nut	13	Key	21	Terminal board	29	Bolt
6	Impeller	14	Rotor	22	Motor Bracket	30	Fan
7	Washer	15	Split ring	23	Cable Fixer	31	Fan Cover
8	Mechanical Seal	16	Screw	24	Nut		

## Hydraulic Performance Curve

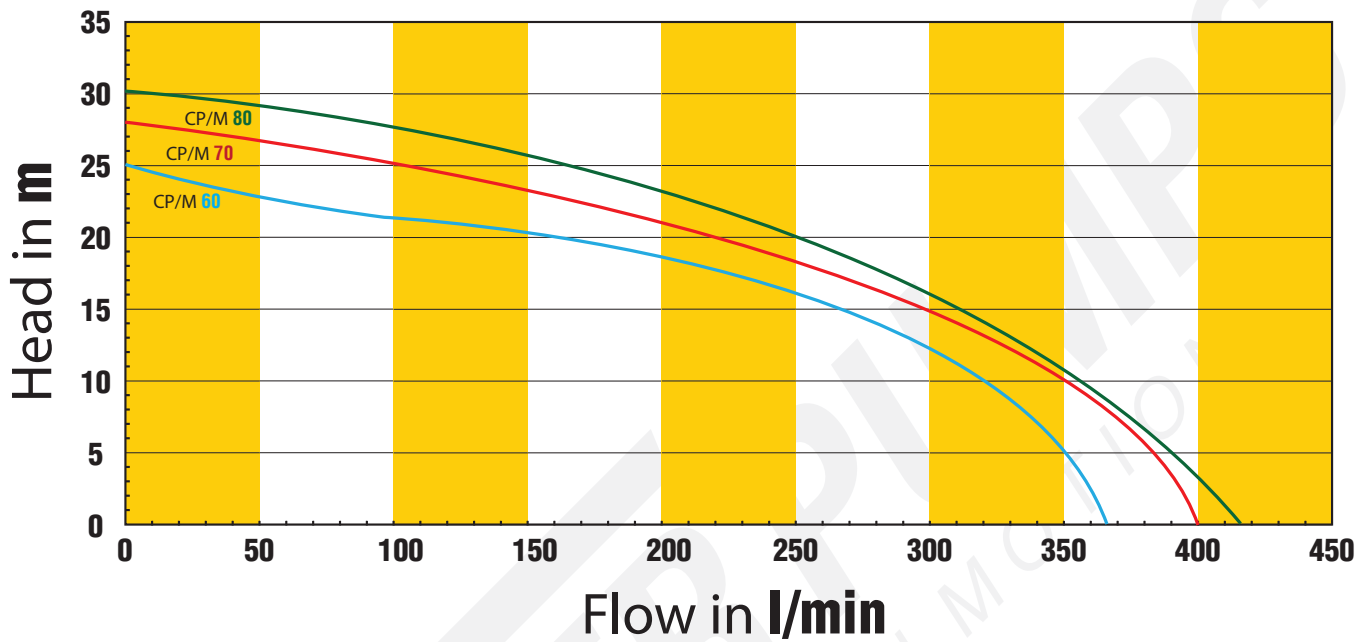

## Technical Data

NO	MODE	POWER		Q (m <sup>3</sup> /h)		0	3	6	9	12	15	18	21	24	27
		1ph / 3ph	kW	HP	Q (l/min)		0	50	100	150	200	250	300	350	400
1	CP/M60	1.1	1.5	H (m)	25	22.8	21.8	20.7	19	16	12.9	4.4			
2	CP/M70	1.5	2		28	26.5	25	23.5	21	18.3	15	10	0		
3	CP/M80	2.2	3		30	29.1	27.6	24.9	22	19.6	16.3	10.8	2.7		

## Dimension

No	Model	Freq.	Suct. Max	Size	Start-up Amps (1ph)	Running Amps (1ph)	Dimension	N/W
	1 ph / 3ph	Hz	m	inch	A	A	L x W x H mm	kg
1	CPM60	50	7	2" x 2"	16	5.2	403x245x310	21.2
2	CPM70	50	7	2" x 2"	23.5	7.5	403x245x310	23.6
3	CPM80	50	7	2" x 2"	30.5	10.2	440x242x295	29.8