



FOUNTAIN RANGE

HB & JHQ



TRACER PUMPS

LEADING IN MOTION

2023 V1

FOUNTAIN PUMP

HB

Application

These pumps can be used in water features, fountains, aquariums and ponds for circulation.

They are highly energy efficient and have a long service life.

Performance range

Maximum head: 2.7m
Maximum flow: 1500L/h
Power: 13.5W TO 27W

Operating limits

Maximum liquid temperature: 40°C
Length of operating time: Continuous duty



Performance chart

MODEL	OUTPUT POWER (W)	MAX HEAD (m)	MAX FLOW (l/h)	CABLE LENGTH (m)	PLUG
HB-410	13.5	1.5	800	1.5	2 point
HB-888	16.5	1.8	1000	1.5	2 point
HB-108	27	2.6	1500	1.5	2 point

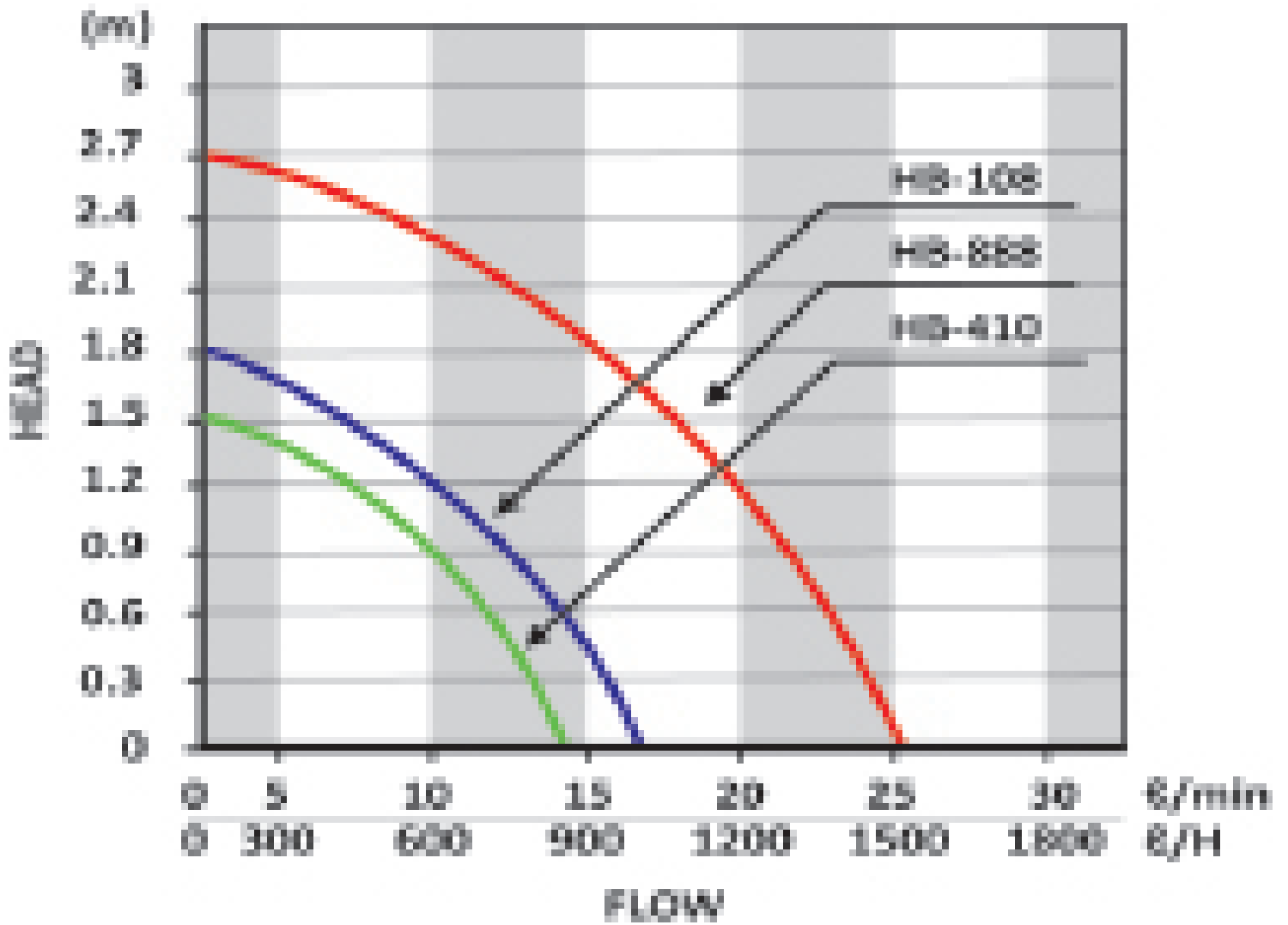

FOUNTAIN PUMP

JHQ

Application

These pumps can be used in water features, fountains, aquariums and ponds for circulation.

They are highly energy efficient and have a long service life.

Performance range

Maximum head:	2.5m
Maximum flow:	2000L/h
Power:	55W

Operating limits

Maximum liquid temperature:	40°C
Length of operating time:	Continuous duty



Performance chart

MODEL	OUTPUT POWER (W)	MAX HEAD (m)	MAX FLOW (l/h)	CABLE LENGTH (m)	PLUG	WEIGHT (kg)	DIMENSIONS L x W x H (mm)
JHQ-2500	55	2.5	2000	3	3 point	1.2	153x105x135

Performance curves

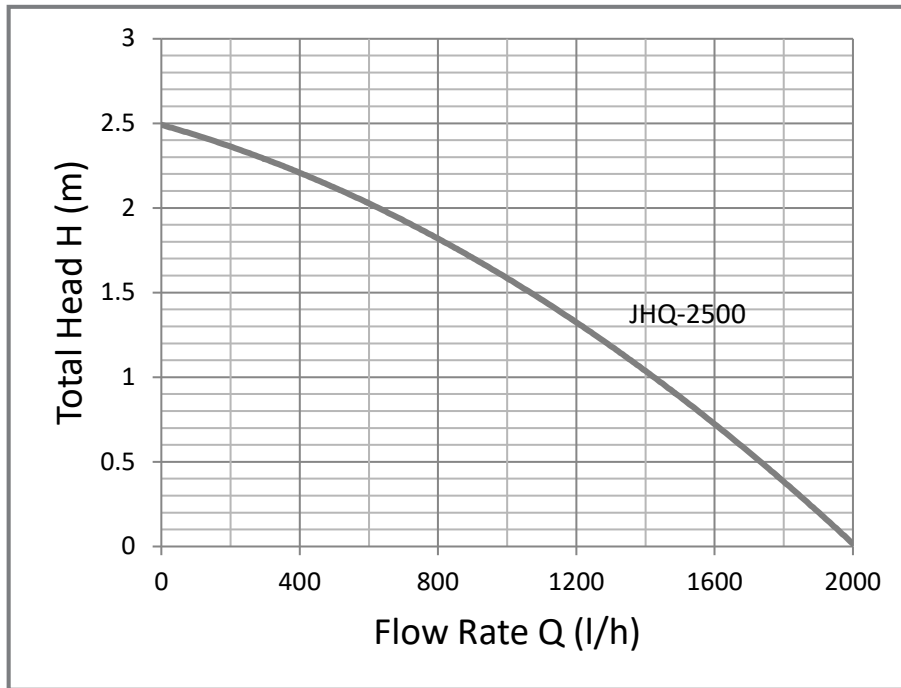

Diagram

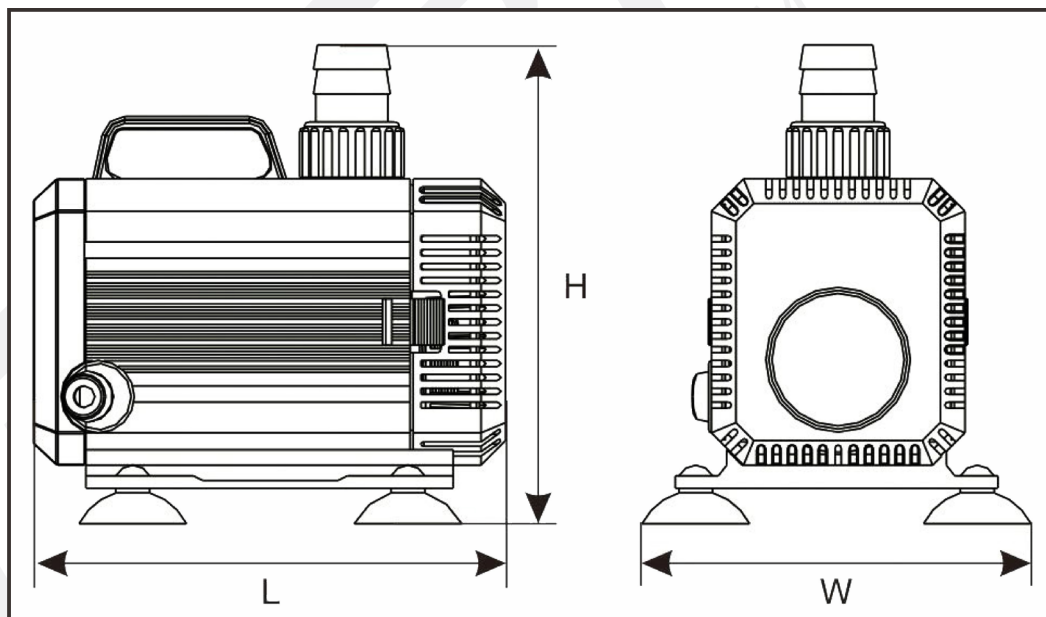

Dimensions

MODEL	WEIGHT	L	W	H
JHQ-2500	1.2kg	153mm	105mm	135mm