



CONTROL EQUIPMENT

H931 DIGITAL 380V STARTER CONTROLLER



TRACER PUMPS

LEADING IN MOTION

2023 V1

Responsibility

The manufacturer is not liable for malfunctioning if the product has not been installed correctly, damaged, modified, run outside the recommended work range or in contrast with other indications given in this manual. The manufacturer declines all responsibility for possible errors in this operation manual, if due to misprints or errors in copying. The manufacturer reserves the right to make any modifications to products that it may consider necessary or useful, without affecting the essential characteristics.

Introduction

The digital starter protection panel VERSION 2 is useful in all cases where it is needed need to control and

protect single pumps, managing its turn-on and turn off by different electrical installations.

Typical usage scenarios include:

- Houses
- Flats
- Holidays houses
- Farms
- Water supply from wells
- Irrigations of greenhouses, gardens, agriculture
- Rain water reuse
- Industrial plants
- Waste water tank / Sewage sink

Technical parameter & features







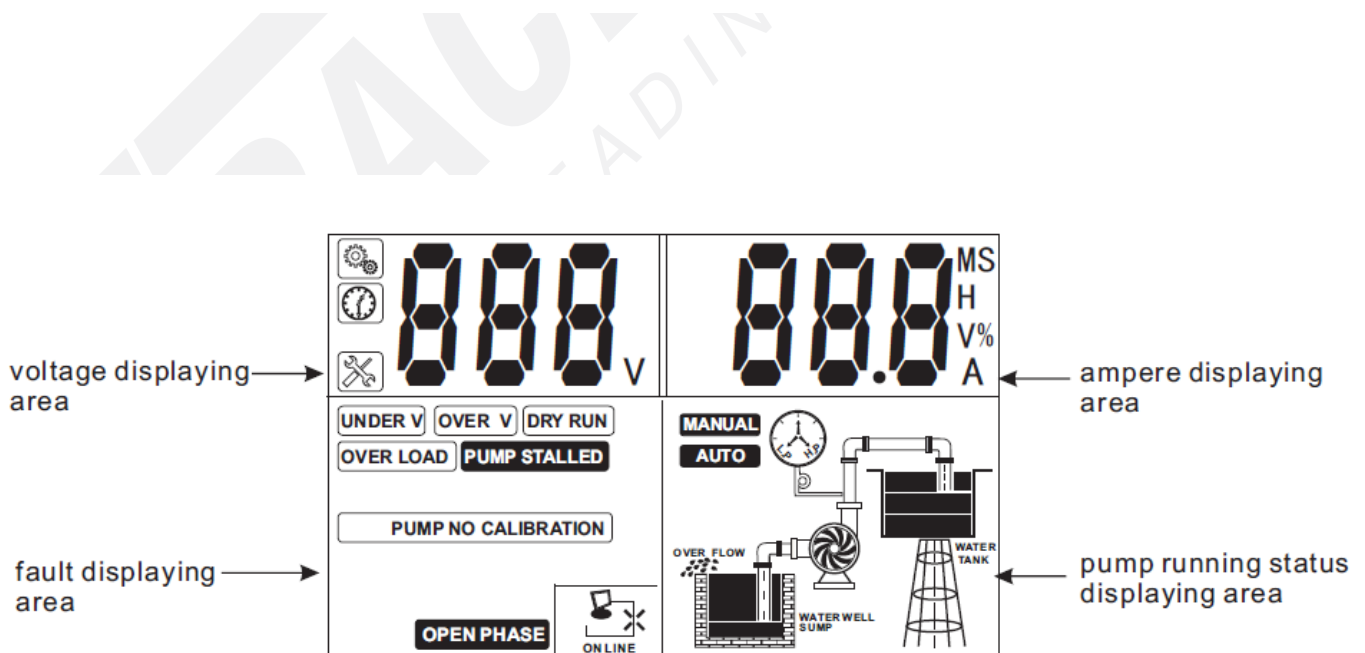
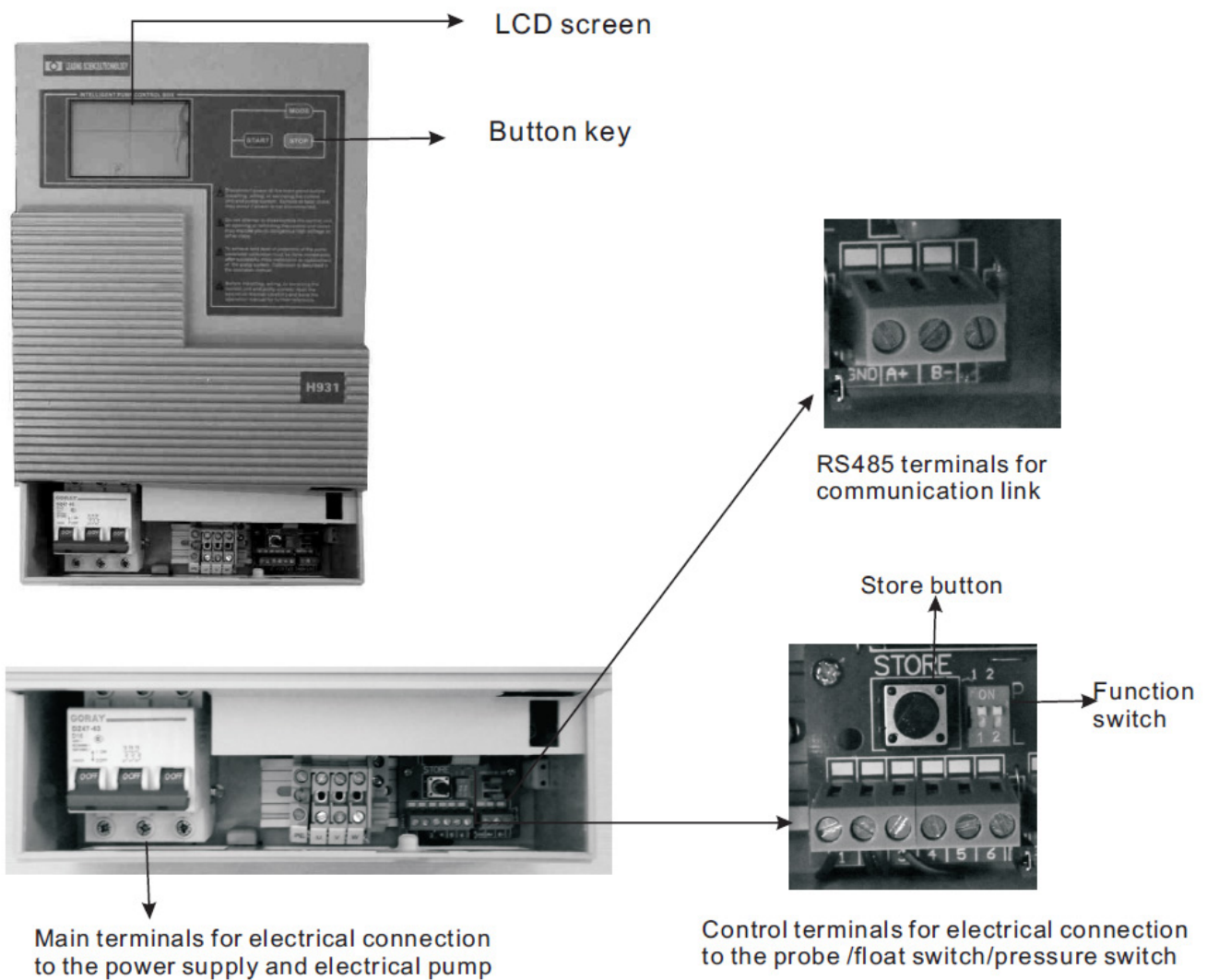

Main features:

- Built In function switch
 - applied for water supply by liquid level control through float switch or liquid probe
 - applied for water supply by pressure control through pressure switch and pressure tank
 - applied for drainage by liquid level control through float switch or liquid probe
- Automaticly stops the pump in the case of water shortage, protecting it from dry running without installing float switch or liquid probe in the well
- Auto / Manual switch
- Dynamic LCD displaying pump running state
- Push Button Calibration
- Pump Accumulative Running Time Displaying
- Pump Last Five Fault Record Displaying
- RS485 Communication
- Starts and stops the pump in accordance with the different liquid level or pressure settings

MAIN TECHNICAL CHARACTERISTIC	
Control characteristic	Double liquid level control
	Pressure control
Control method	Manual / Auto
Liquid level control characteristic	Pulse electrode probe & float switch
Pressure control characteristic	Pressure switch (n/c) & pressure tank
MAIN TECHNICAL DATA	
Rated output power	0.75-4KW (1HP-5.5HP) 5.5-11KW (7.5HP-15HP) 15KW (20HP)
Rated input voltage	AC380V/50HZ Three Phase
Trip response time of over load	5sec-5min
Trip response time of open phase	< 2 sec
Trip response time of short circuit	< 0.1sec
Trip response time of under / over voltage	< 5sec
Trip response time of dry run	6sec
Recovery time of over load	30min
Recovery time of under / over voltage	5min
Recovery time of dry run	30min
Trip voltage of over voltage	420V
Trip voltage of under voltage	340V
Liquid level transfer distance	≤1000m
Protection function	Dry run Over load Transient surge Under voltage Over voltage Open phase Pump stalled Short circuit
MAIN INSTALLATION DATA	
Working temperature	-25°C to 55°C
Working humidity	20% - 90%RH, no drips concreted
Degree of protection	IP22
Install position	Vertical
Unit dimensions (L x W x H)	37×12.5×27.6 cm
Unit weight (net)	3.6kg
RS485 TECHNICAL DATA	
Physics Interface	RS485 Bus Interface: asynchronism semiduplex
Baud rate	1200 bps, 2400 bps, 4800 bps, 9600bps Default: 9600bps
Protocol type	MODBUS Protocol (RTU)

1.3 Controller components



Icon	Meaning/Description
	pump parameter configuration icon, when this icon appears, pump control box is in parameter adjusting manual;
	time displaying icon, when this icon appears, it means pump control box is displaying some parameter of time, eg: pump accumulative running time (unit: hour); counting down etc
	pump fault icon, when this icon appears, it means pump control box is displaying some fault information;
 ON LINE	network connection error icon, when this icon appears, it means there is no network connections or network connection error between pump control box and SC(slave controller) or computer;
 ON LINE	network normal connection icon, when this icon appears, it means the network connection between pump control box and SC (slave controller) or computer is normal;
V	voltage
M	minute
S	second
H	hour
%	percent
A	ampere
	pump running
	pump stops running
	low pressure or lack of pressure in the pipeline or pressure tank
	high pressure or full of pressure in the pipeline or pressure tank

2.1 Electrical connection to the power supply line and electrical pump

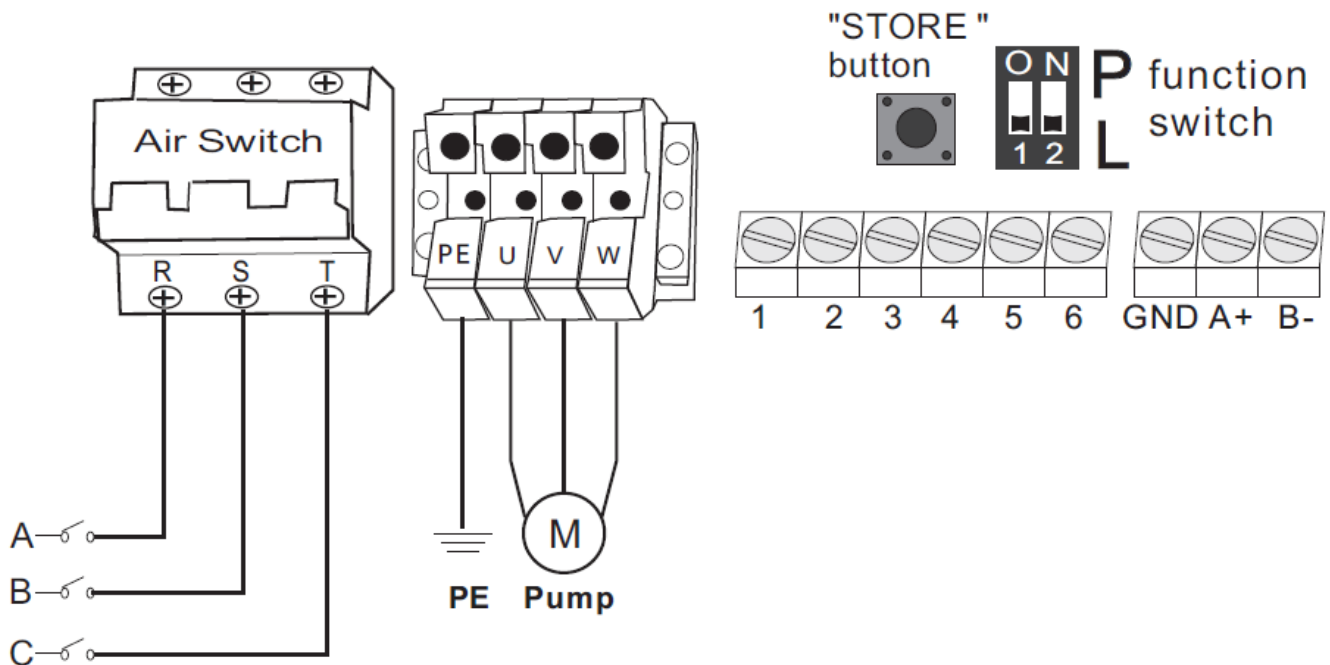

DANGER Electric shock risk

Before carrying out any installation or maintenance operation, the A18 should be disconnected from the power supply and one should wait at least 2 minutes before opening the appliance.



Never connect AC power to output UV W terminals.



Don't put wire, metal bar filaments etc into the controller.



Ensure the motor, controller and power specifications matching.



The electrical and hydraulic connections must be carried out by competent, skilled, qualified personnel.

2.2 Function switch setting

Pump users can set the function switch to meet different application requirement, before setting the function switch, the A18 should be disconnected from the power supply, after complete the setting, apply power to A18 and observe the application sign displayed on the LCD conforming to the following list.

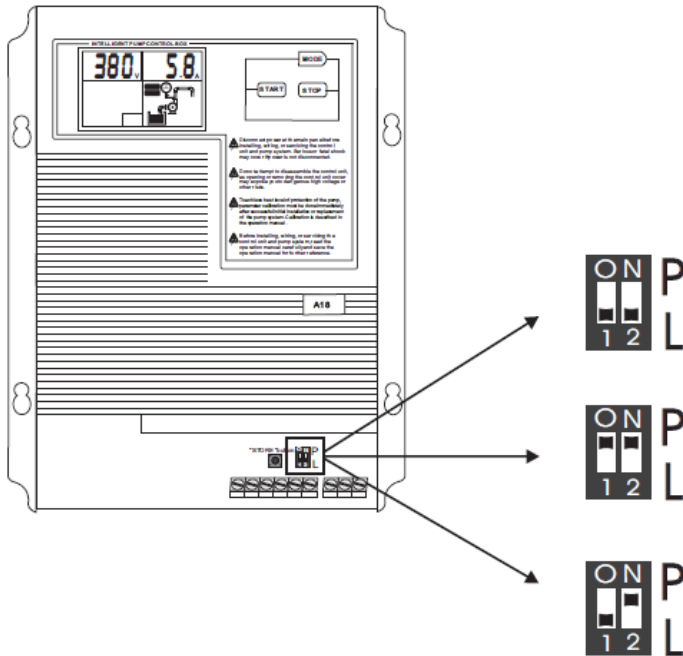

Item	Swith position	Messages & Graphic	Application
1			Applied for water supply or drainage by liquid level control through float switch or liquid sensor
2			Applied for water supply by pressure control through pressure switch & pressure tank
3			Applied for drainage by liquid level control through float switch & liquid probe

2.3 Parameter Calibration setting & erasing

To achieve best level of protection of the pump, it is essential that parameter calibration must be done immediately after successful pump installation or pump maintenance.

Setting the parameter calibration

- Press the **MODE** key to switch to manual state, make sure the pump not running and LCD screen displaying:

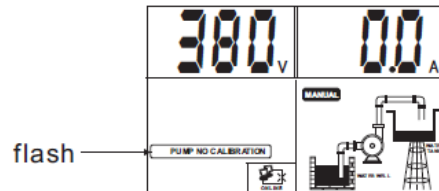

- Press the **START** key to run pump, confirm the pump and all pipe network in normal working state (including voltage, running ampere et); LCD screen displaying:

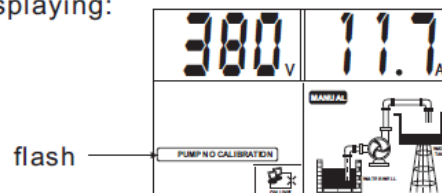

- Press the **STORE** button; The A18 makes a "Di" sound and starts 20 seconds countdown, LCD screen displaying:

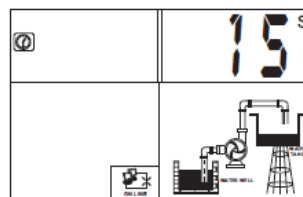

- Pump stops running and parameter calibration completed, LCD screen displaying:
A18 is ready for running.

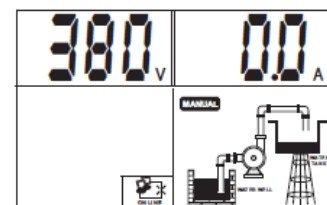

Erasing former parameter calibration

When pump is reinstalled after maintenance or new pump is installed, user must erase the former parameter calibration and a new calibration must be done.

Erasing the parameter calibration

- Press the **MODE** key to switch to manual state, make sure the pump not running and LCD screen displaying:

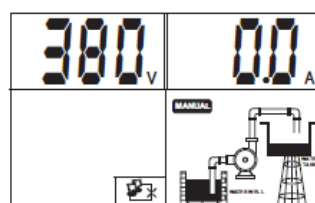

- Press the **STOP** key and release till A18 makes a "Di" sound, A18 recover the default factory setting and LCD screen displaying:

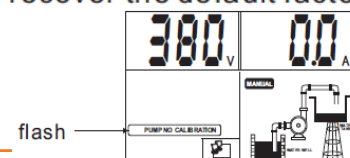

3.1 Installing liquid probe & float switch

Liquid probe installation

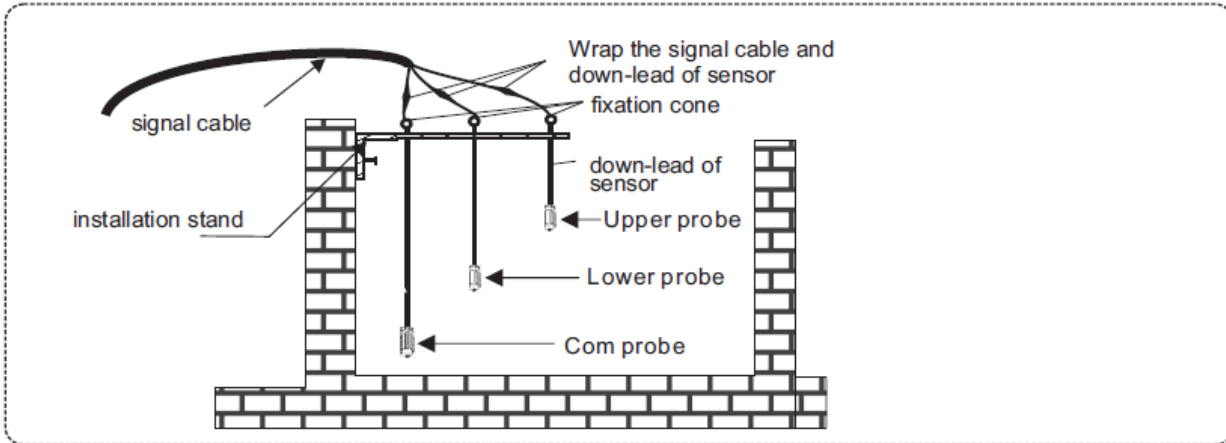

! In event of high risk of electric storms (lightning) or when liquid medium in well or tank or sump is very dirty it is recommended float switch is used.

Float switch installation

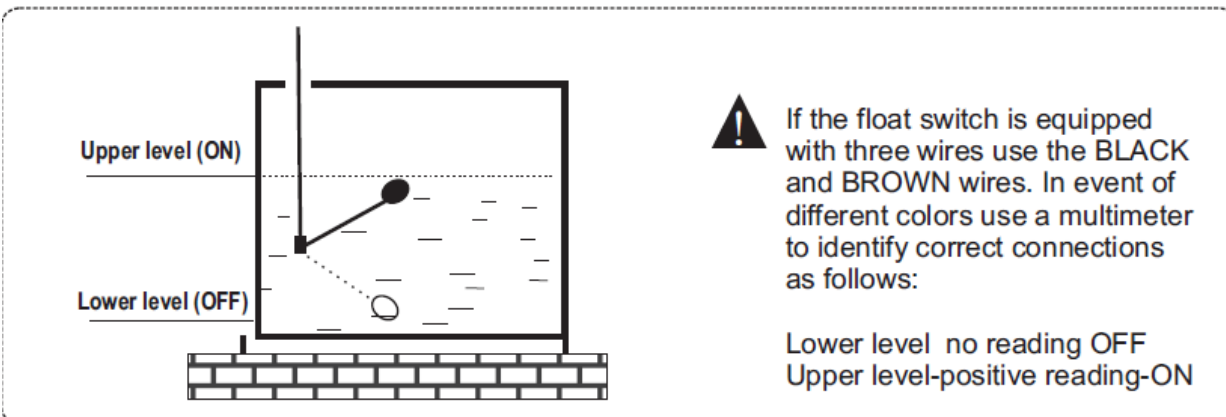

! If the float switch is equipped with three wires use the **BLACK** and **BROWN** wires. In event of different colors use a multimeter to identify correct connections as follows:

Lower level no reading OFF
Upper level-positive reading-ON

! **DO NOT ENCASE SENSOR LEADS, FLOAT SWITCH WIRE OR SIGNAL CABLES IN METAL PIPES. USE PVC OR PE TUBING.**

3.2 Electrical connection for different application

3.2.1 Water supply by liquid level control through float switch or liquid probe

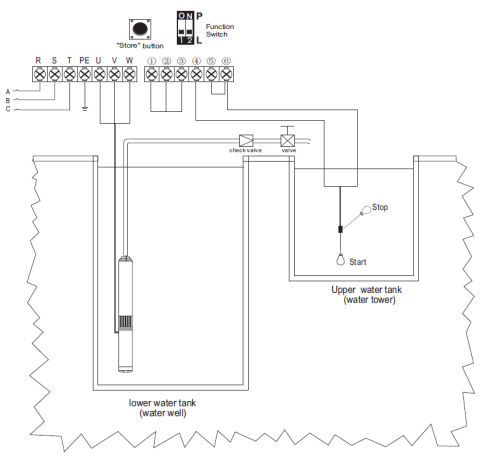
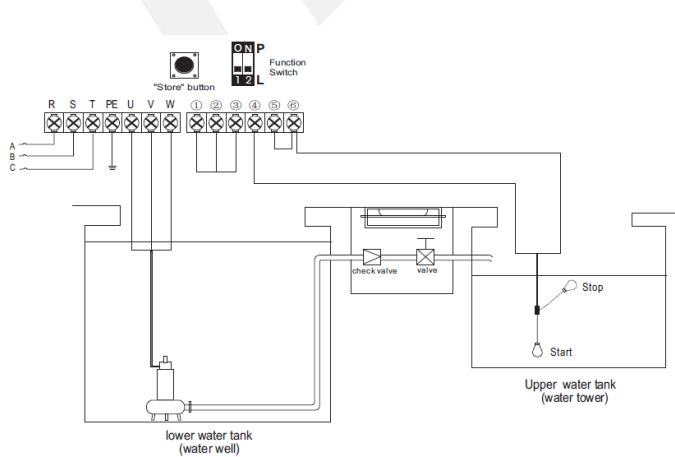
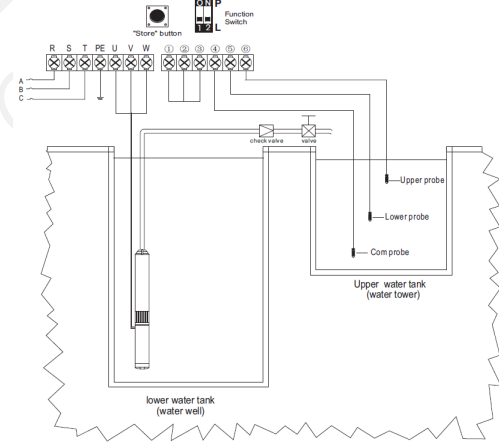
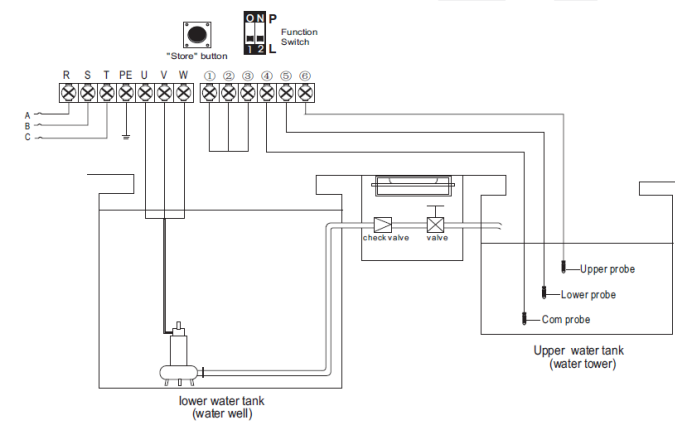
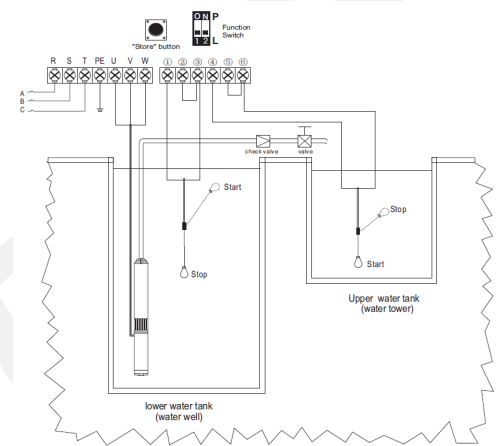
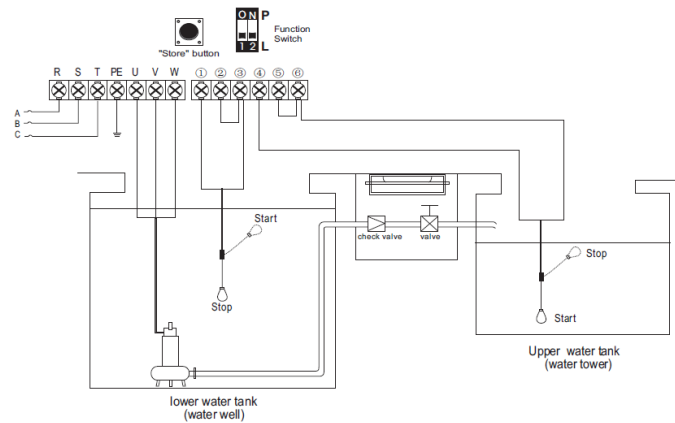
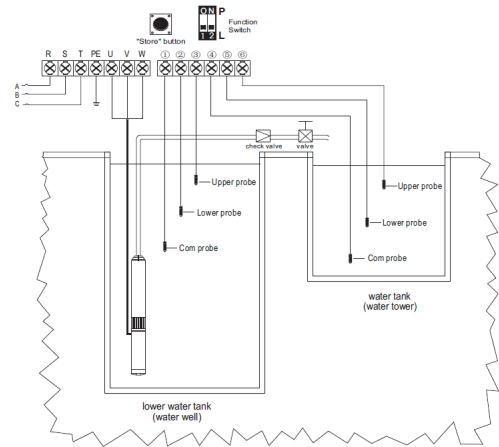
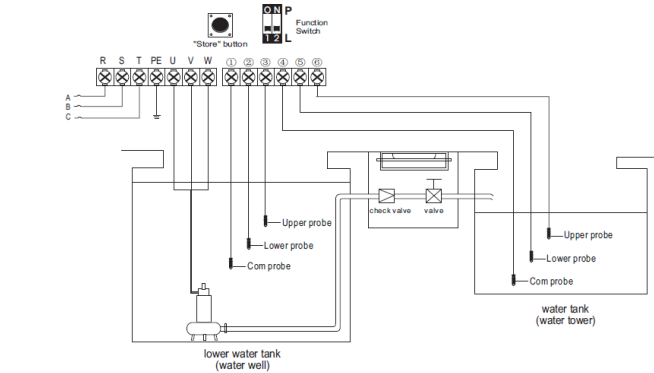

1). Starting condition

liquid level in the water tank is below Lower probe (float switch: Down level) and liquid level in the water well is above Lower probe (float switch: Up level), the panel will run pump;

2). Stop condition

liquid level in the water tank reaches Upper probe (float switch: Up level) or liquid level in the water well is below Lower probe (float switch: Down level); the panel will stop pump running;

3). The probe / sensor free in the water well

as the panel has reliable and automatic stop function against pump dry-run (dewatering), if it is used in submersible pump for deep well, pipeline pump or other situations when it is inconvenient to install lower liquid probe in the well, pump users can put terminals 1,2,3 in short circuit, which minimize the troubles and costs.

4). Meaning of the messages & graphic shown on the LCD screen:

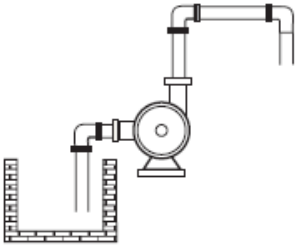
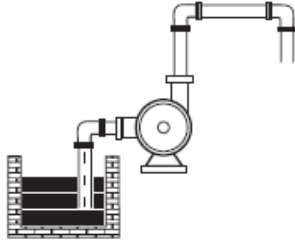
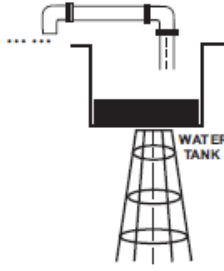
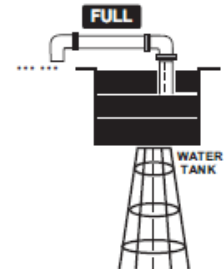
Messages & Graphic	Description
	<p>Lack of water in water well</p>
	<p>Full of water in water well</p>
	<p>Lack of water in water tank</p>
	<p>Full of water in water tank</p>

3.2.2 Water supply by pressure control through pressure switch & pressure tank

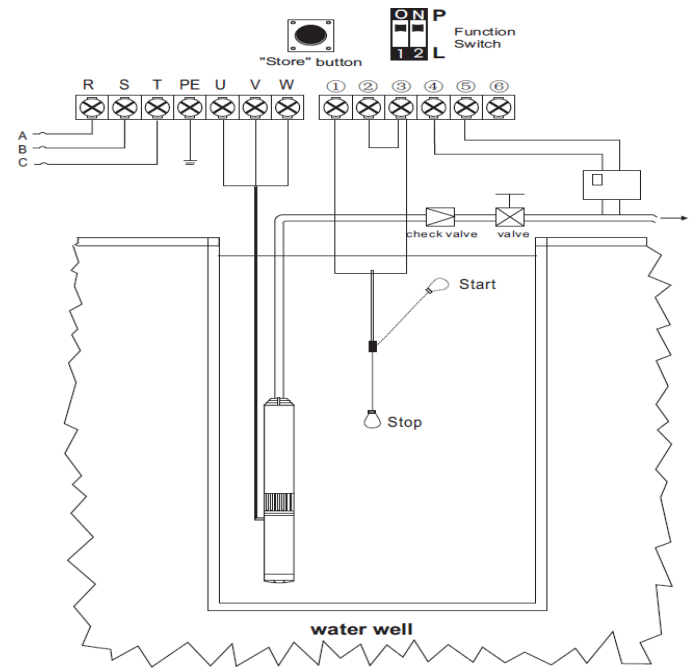
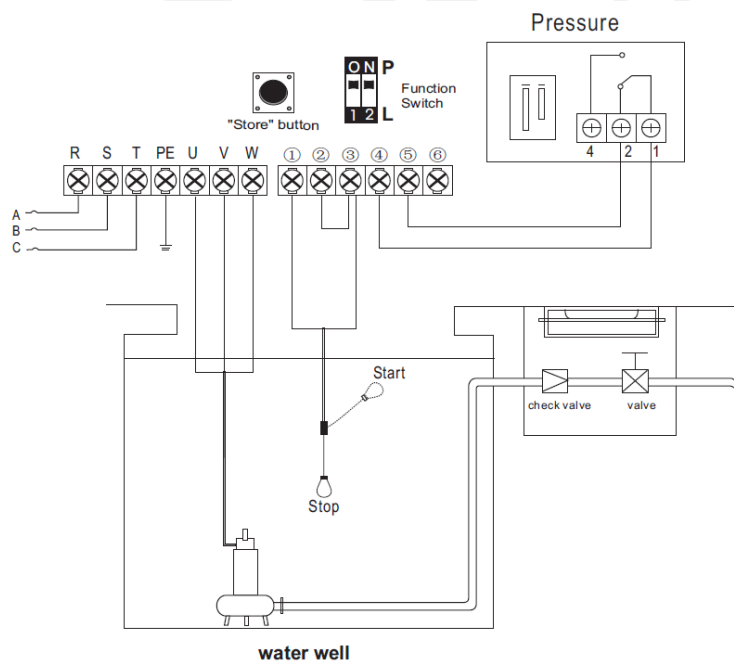
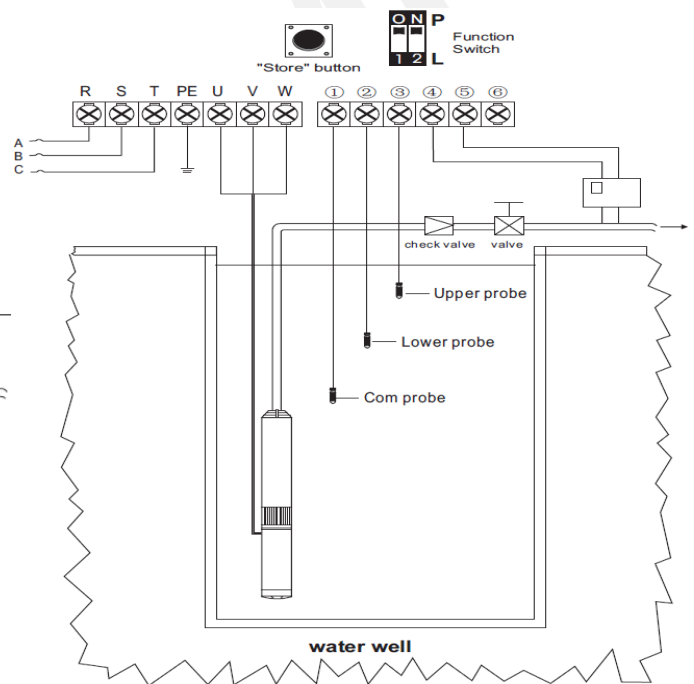
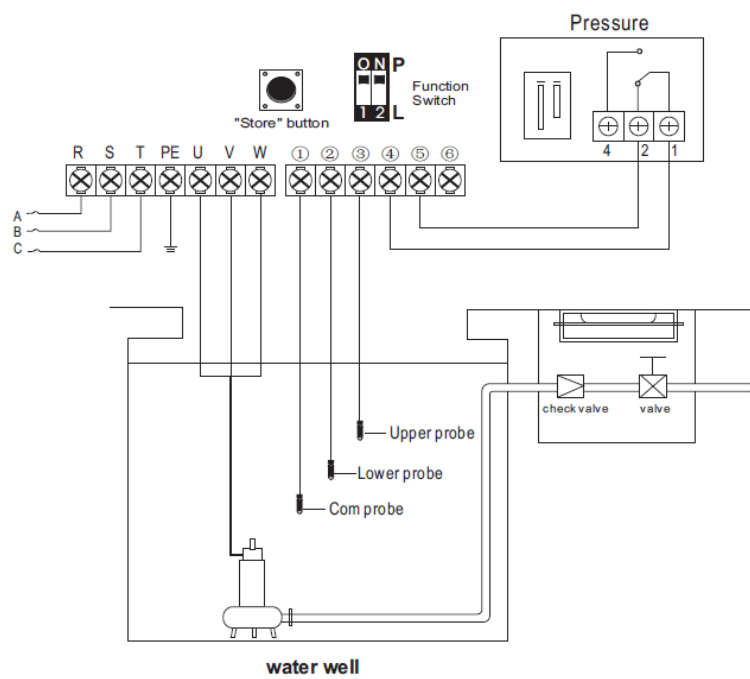
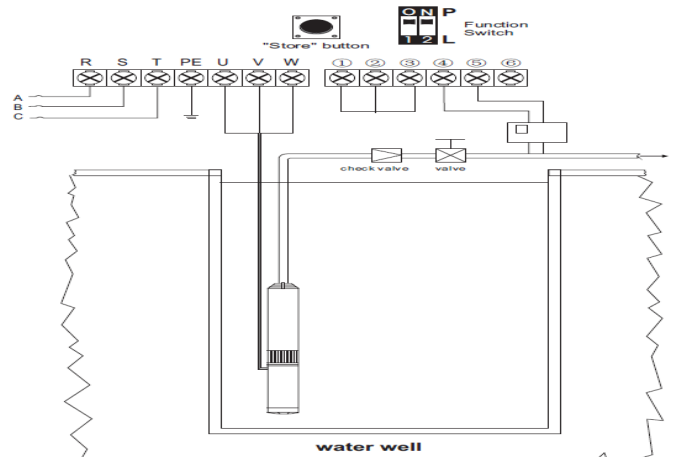
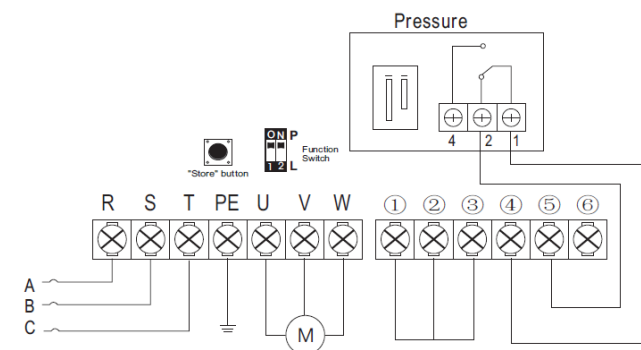

3.2 Installing pressure switch and pressure tank

1). Starting condition

there is no pressure in the pipeline or pressure tank, contacting point of pressure switch is ON and liquid level in the water well is above Lower probe (float switch: Up level), the panel will run the pump.

2). Stop condition

there is full pressure in the pipeline or pressure tank, contacting point of pressure switch is OFF, the panel will stop pump.



Note: pressure switch with N/C (normal close) contacting point:

no pressure, contacting point is ON; meet the pressure setting, contacting point is OFF

3). The probe / sensor free in the water well

as the panel has reliable and automatic stop function against pump dry-run (dewatering), if it is used in submersible pump for deep well, pipeline pump or other situations when it is inconvenient to install lower liquid probe in the well, pump users can put terminals 1, 2, 3 in short circuit, which minimize the troubles and costs.

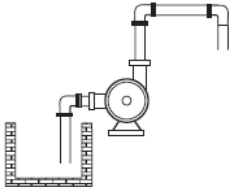
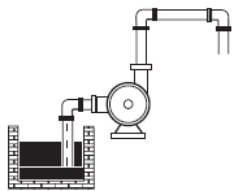
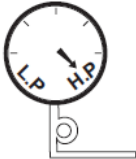
4). Meaning of the messages & graphic shown on the LCD screen:

Messages & Graphic	Description
	Lack of water in water well
	Full of water in water well
	Full of pressure in pipeline or pressure tank
	Lack of pressure in pipeline or pressure tank